

Engineering Department
Manual Of
Practice



Life. Well Crafted.

Date:01-03-2024

Manual Of Practice

Table Of Contents

No.	Description
100	Erosion/Sedimentation Control
101	General Notes For Erosion/Sedimentation Control
102	Temporary Silt Fence
103	Temporary Diversion Cross-Section
104	Block & Gravel Drop Inlet Protection
105	Rock Pipe Inlet Sediment Trap
106	Modified Small Drainage Area Rock Pipe Inlet Sediment Trap
107	Yard Inlet Protection
108	Rip-Rap Outlet Protection
109	Temporary Sediment Trap
111	Dead End Street Erosion Control Device
112	Temporary Stone Ditch Check
113	Temporary Slope Drain Detail
114	Temporary Gravel Construction Entrance
200	Drainage
201	General Notes For Drainage
202	Curb Inlet
203	Curb Inlet Throat For 2'-6" Curb & Gutter
206	4'x4' Brick Masonry Yard Inlet
300	Streets
301	General Notes For Streets
302	Parkway Cross-Sections
303	Arterial Street Cross-Sections
304	Collector Street Cross-Sections
305	Local Street Cross-Sections
306	Alley Cross-Section
307	Required Intersection Site Triangle
308	Sight Triangle For Divided Entrance
309	Speed Hump
310	Speed Table Or Pedestrian Table
311	Trench Detail For Road Patch & Repair
312	Symmetrical & Offset Cul-De-Sac
313	Heavy Equipment Turning Radii
314	Street Right-of-Way Survey Requirements
315	Turn Around For Dead End Street
400	Curb & Gutter, Sidewalks & Driveways
401	General Notes For Curb & Gutter, Sidewalks, & Driveways
402	Typical Driveway Cut
404	Driveway Turnout Radius Type
405	Design Standards For Street Turnouts
406	Standard 30" Curb And Gutter

407	30" Valley Gutter
408	Curb And Gutter For Variable Super Elevations Rates
409	Sidewalks
410	Standard Wheelchair Ramp
411	8"x12" Median Curb
412	Concrete Islands
413	Channelized Right Turn Concrete Island
414	Right-In/Right-Out Driveway Standard
500	Water Systems
501	General Notes For Water Systems
502	Typical Residential Connection And Hydrant Setting Detail
503	Fire Hydrant Installation Detail
504	Thrust Block For Water Mains (150 PSI Working Pressure)
505	Concrete Encasement For Manhole & Castings In Pavement
506	Tapping Sleeve & Valve Assembly
507	Double Detector Check Valve Assembly With Meter
508	Water Line Trench Bottom Dimensions And Backfilling Requirements
509	Water Line Installation In Roadway Shoulder
510	Air Blow-Off Assembly
511	Meter Vault Without Bypass
512	Meter Vault With Bypass
513	Vertical Gate Valve Assembly
514	Blow-Off Detail
515	Typical Water Service Connection
516	Bore Encasement Detail
517	Typical Dead End With Fire Hydrant
518	Fire Sprinkler Backflow Prevention
519	Road Patch And Repair
520	1 1/2" - 2" Standard Water Service Connection
	Water Specifications
	Section 02200 Earthwork
	Section 02222 Excavating Backfilling
	Section 02227 Boring Encasement
	Section 02400 Thrust Blocking
	Section 02401 Water Valves, Valve Boxes, Air Relief Valves, Tapping Sleeve & Valves
	Section 02402 Fire Hydrant & Appurtenances
	Section 02500 Leakage Testing
	Section 02501 Sterilization
	Section 02570 Bituminous Pavement Repair
	Section 02660 Water System
	Section 02661 Water System Design Spec
	Section 02668 Water Service Connections
	Section 02900 Road Restoration Of Surfaces
	Section 02930 Seeding & Landscaping
600	Sewer System
601	General Notes for Sewer System
602	Sewer Line Trench Bottom Dimensions And Backfilling Requirements

603	Sanitary Sewer Manhole Detail
604	Sanitary Sewer Drop Manhole
605	Standard & Short Manhole Ring & Cover
606	Manhole Step For Precast Concrete Manhole
607	Residential Sewer Tap
608	Low Pressure Sewer Cleanout Box
609	Low Pressure Sewer Service Box
610	Low Pressure Sewer Service Connection
611	Low Pressure Sewer Partial Lateral Service
612	Low Pressure Sewer Lateral Service
613	Low Pressure Sewer Individual System
614	Inside Drop Connection For Precast Concrete Manhole (Fiberglass Drop Bowl)
615	Typical Grease Trap Detail
616	Road Patch And Repair
617	Sewage Force Main Combination Air Valve
	Sewer Specifications
	Section 02200 Earthwork
	Section 02222 Excavating Backfilling
	Section 02227 Boring Encasement
	Section 02570 Bituminous Pavement Repair
	Section 02601 Manholes Drop Connections And Conflict Manholes
	Section 02722 Exterior Sanitary Sewers And Appurtenances
	Section 02723 Low Pressure Sewer System
	Section 02900 Road Restoration Of Surfaces
	Section 02930 Seeding And Landscaping
700	Landscaping
701	General Notes for Landscaping
702	Planting Small Trees Up To And Including 2" Caliper
703	Planting Large Trees Greater Than 2" Caliper
800	Solid Waste
801	General Notes For Solid Waste
802	Single Dumpster Pad
803	Double Dumpster Pad
806	Bollard Detail For Dumpster

Engineering Department
Manual Of
Practice



Life. Well Crafted.

100 Erosion/Sedimentation Control

NOT TO SCALE



CITY OF HICKORY
GENERAL NOTES FOR
EROSION/SEDIMENTATION CONTROL

DATE:
2-1-07

SHEET 1 OF 1

STD. NO.
101

NOTE: POSTS SHALL BE SPACED AT A MAXIMUM OF 8' IF FENCE IS SUPPORTED WITH WIRE, AND A MAXIMUM OF 6' IF FENCES USES EXTRA STRENGTH FABRIC WITHOUT SUPPORT WIRE.

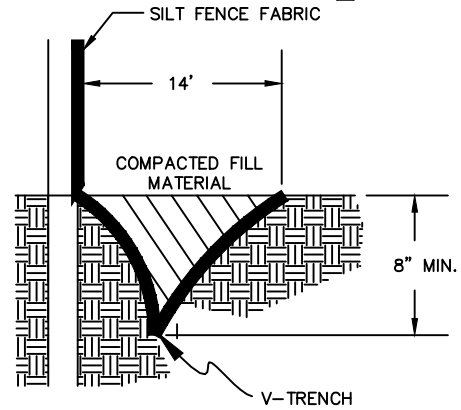
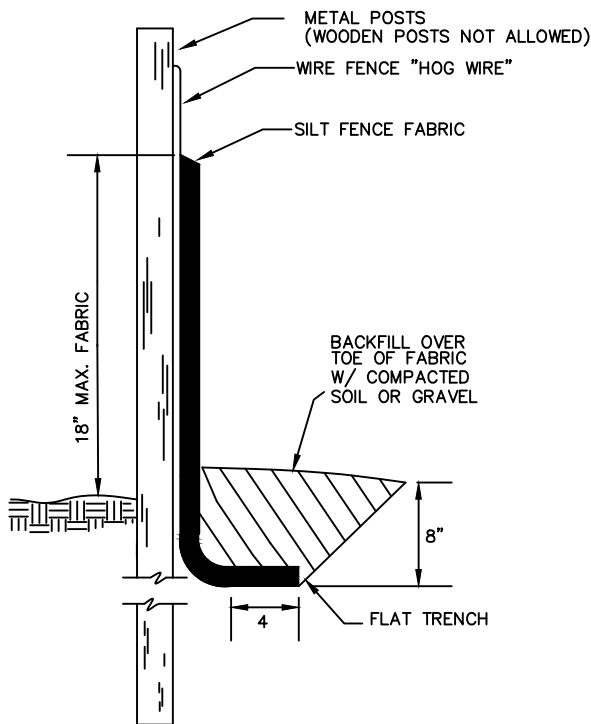
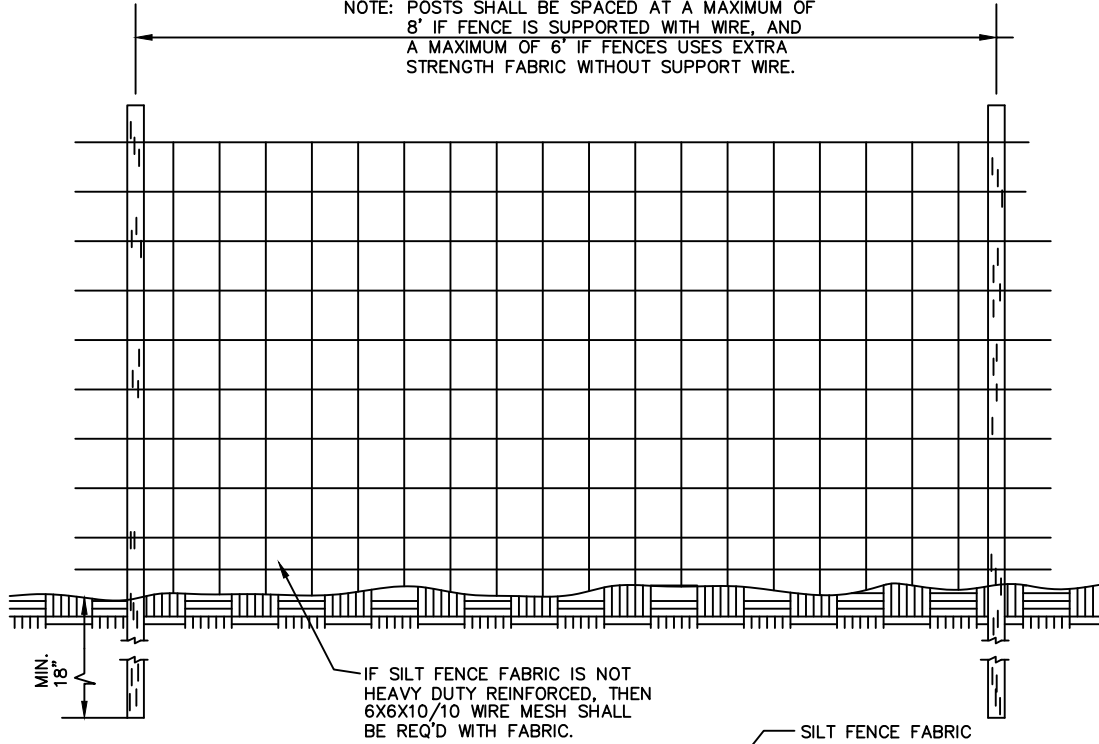

ALTERNATE TRENCHING DETAIL

GENERAL NOTES

- 1) FENCE FABRIC SHALL BE A MINIMUM OF 32" IN WIDTH AND SHALL HAVE A MINIMUM OF 6 LINE WIRES WITH 12" STAY SPACING.
- 2) SILT FENCE FABRIC SHALL BE SYNTHETIC OR OTHER APPROVED MATERIAL MEETING AN 85% MIN. FILTERING EFFICIENCY AND MIN. 30 LB./ LIN IN TENSILE STRENGTH WITH A MIN 6 MONTH EXPECTED USEABLE CONSTRUCTION LIFE. INSTALL FABRIC IN ACCORDANCE WITH MANUFACTURER'S INSTRUCTIONS.
- 3) STEEL POST SHALL BE THE SELF-FASTENER ANGLE STEEL TYPE.
- 4) BACKFILL OVERTOP OF FABRIC SHALL BE COMPACTED TO A MINIMUM OF 95% MODIFIED PROCTOR

NOT TO SCALE



CITY OF HICKORY

TEMPORARY SILT FENCE

DATE:
2-1-07

SHEET 1 OF 1
STD. NO.
102

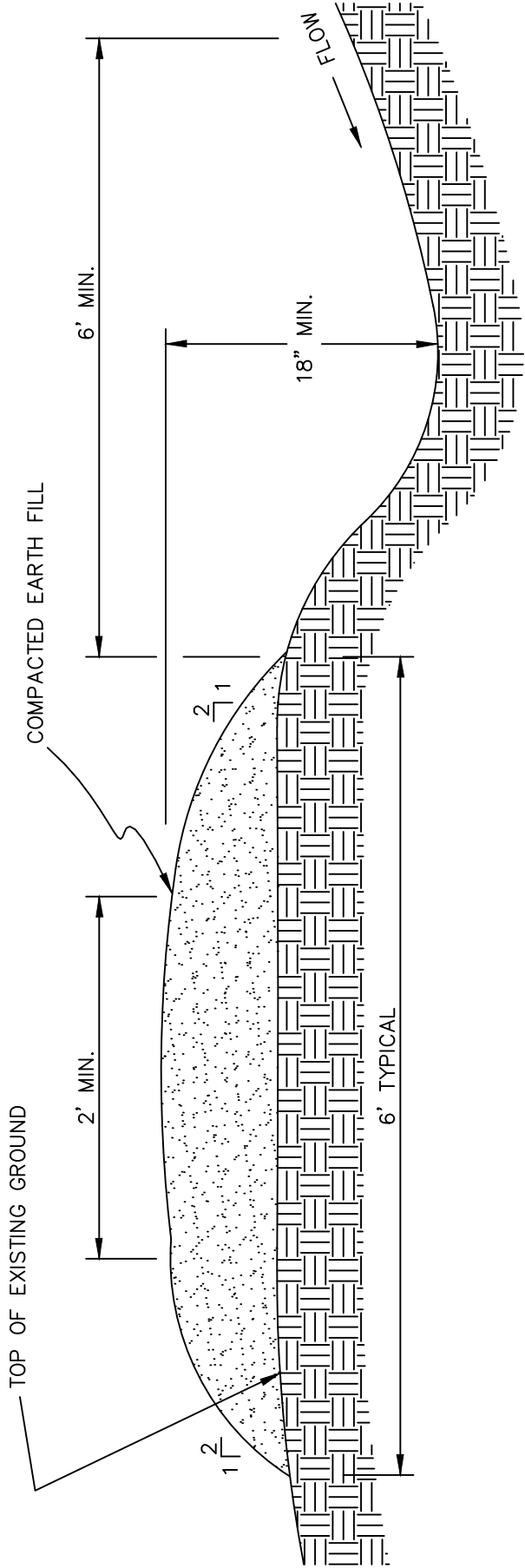

NOT TO SCALE



CITY OF HICKORY

TEMPORARY DIVERSION
CROSS-SECTION

SHEET 1 OF 1	
DATE: 2-1-07	STD. NO. 103

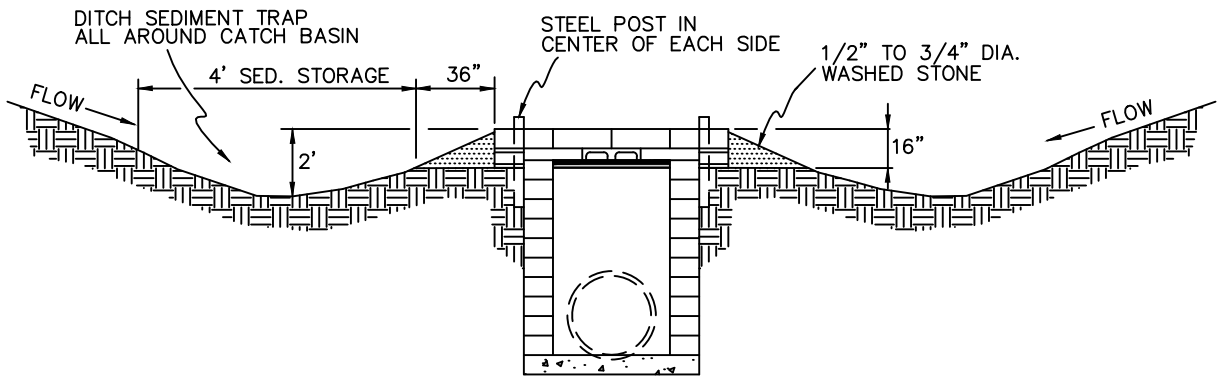
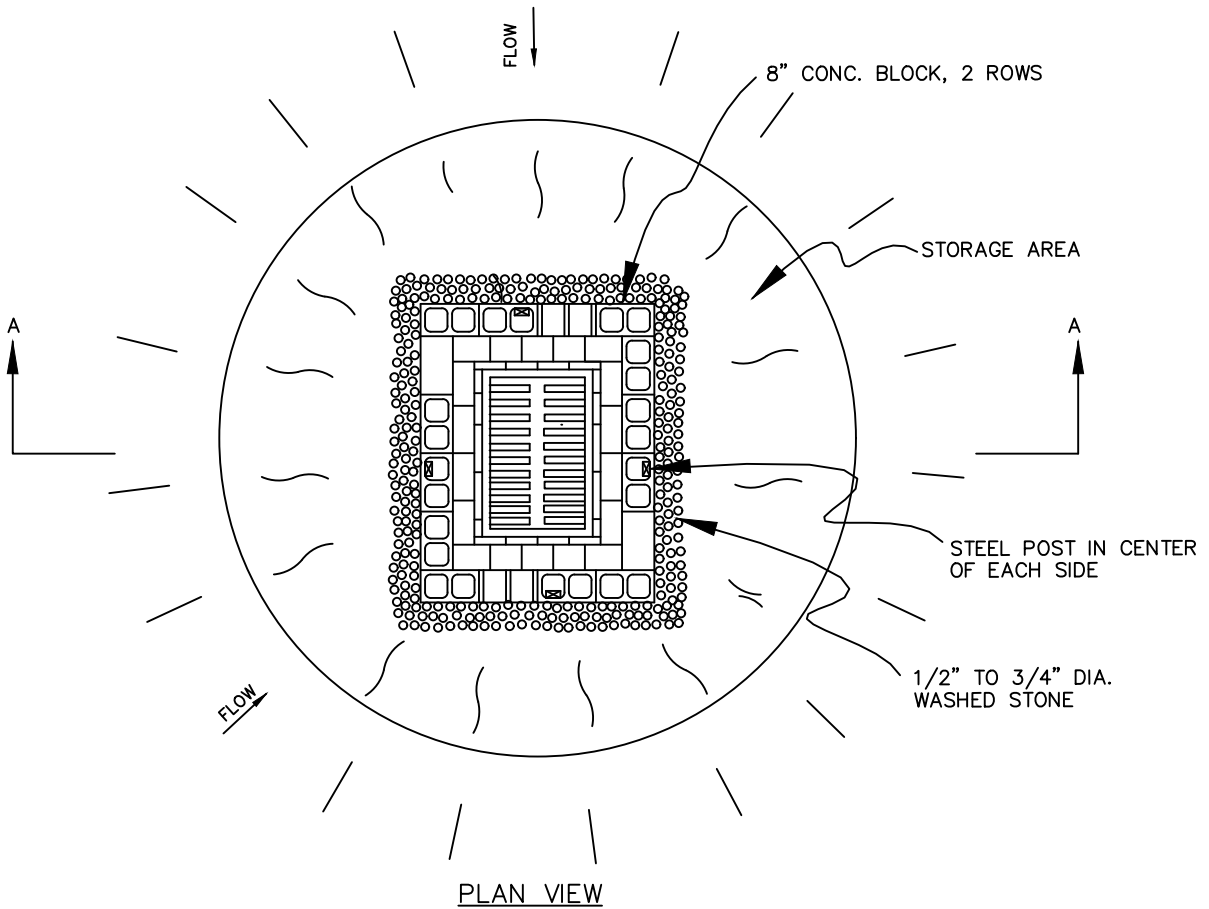

GENERAL NOTES:

SEDIMENT SHALL BE REMOVED AND TRAP RESTORED TO ITS ORIGINAL DIMENSIONS WHEN THE SEDIMENT HAS ACCUMULATED TO 1/2 THE DESIGN DEPTH OF THE TRAP. REMOVED SEDIMENT SHALL BE DEPOSITED IN A SUITABLE AREA AND IN SUCH A MANNER THAT IT WILL NOT ERODE.

THE STRUCTURE SHALL BE INSPECTED AFTER EACH RAIN AND REPAIRS MADE AS NEEDED.

CONSTRUCTION OPERATIONS SHALL BE CARRIED OUT IN SUCH A MANNER THAT EROSION AND WATER POLLUTION SHALL BE MINIMIZED.

THE SEDIMENT TRAP SHALL BE REMOVED AND THE AREA STABILIZED WHEN THE REMAINING DRAINAGE AREA HAS BEEN PROPERLY STABILIZED.

NOT TO SCALE



CITY OF HICKORY

BLOCK & GRAVEL
DROP INLET PROTECTION

SHEET 1 OF 1

DATE:
2-1-07

STD. NO.
104

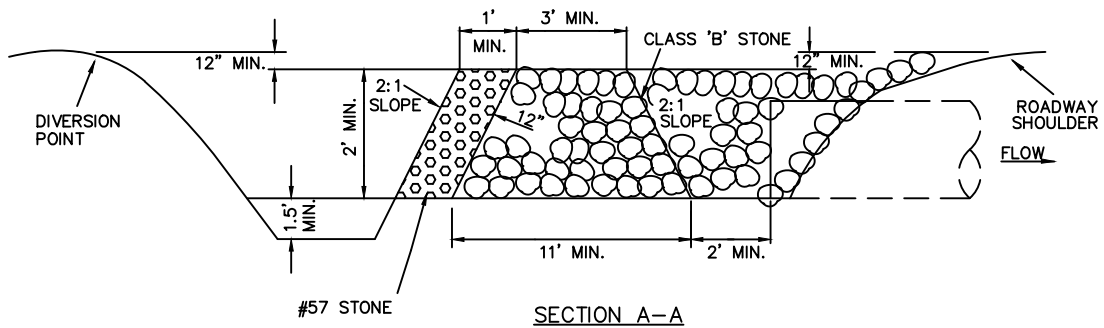
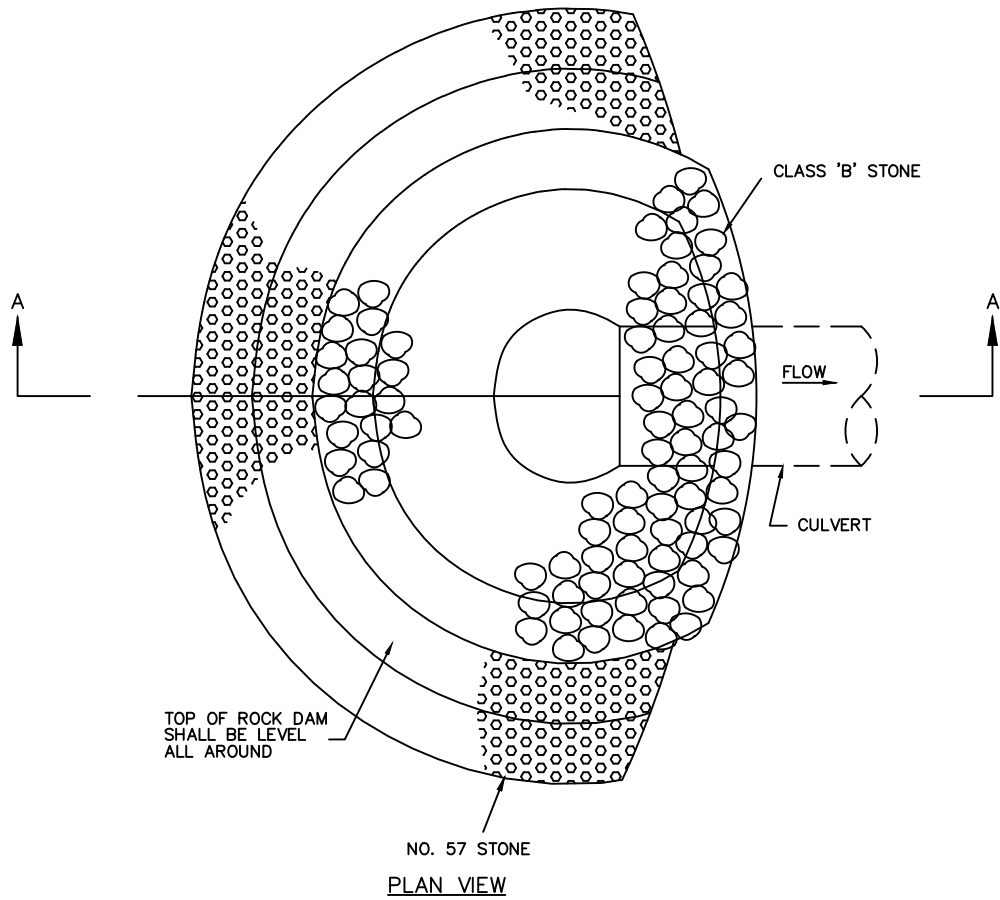

NOT TO SCALE



CITY OF HICKORY

ROCK PIPE INLET
SEDIMENT TRAP

SHEET 1 OF 1

DATE:
2-1-07

STD. NO.
105

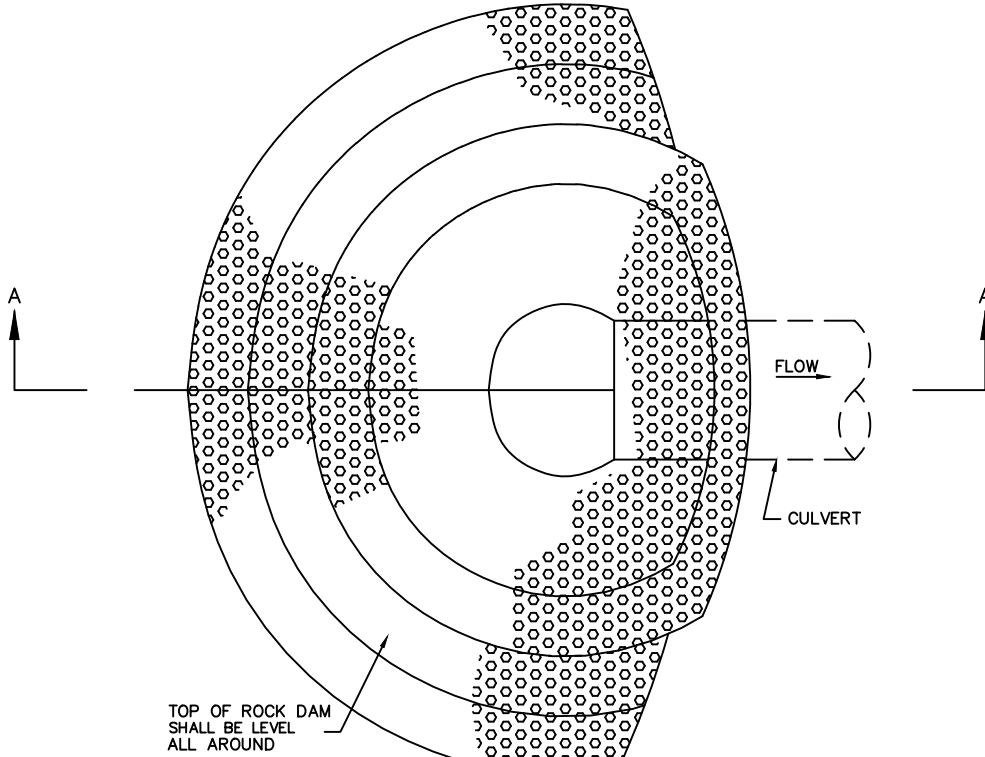

57 STONE
PLAN VIEW

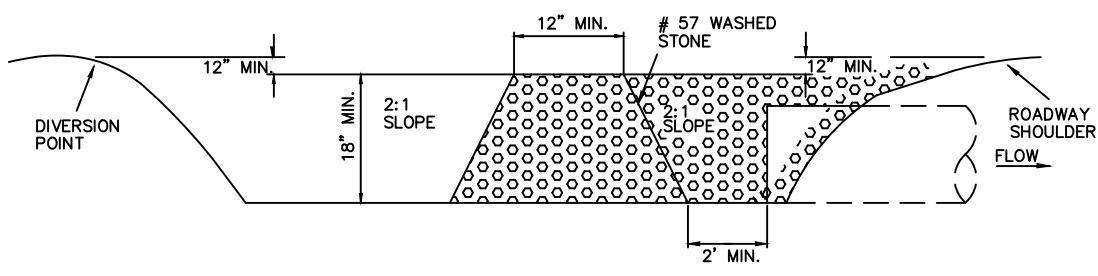

SECTION A-A

NOT TO SCALE



CITY OF HICKORY

MODIFIED SMALL DRAINAGE AREA
ROCK PIPE INLET
SEDIMENT TRAP

DATE: 2-1-07	SHEET 1 OF 1 STD. NO. 106
-----------------	---------------------------------

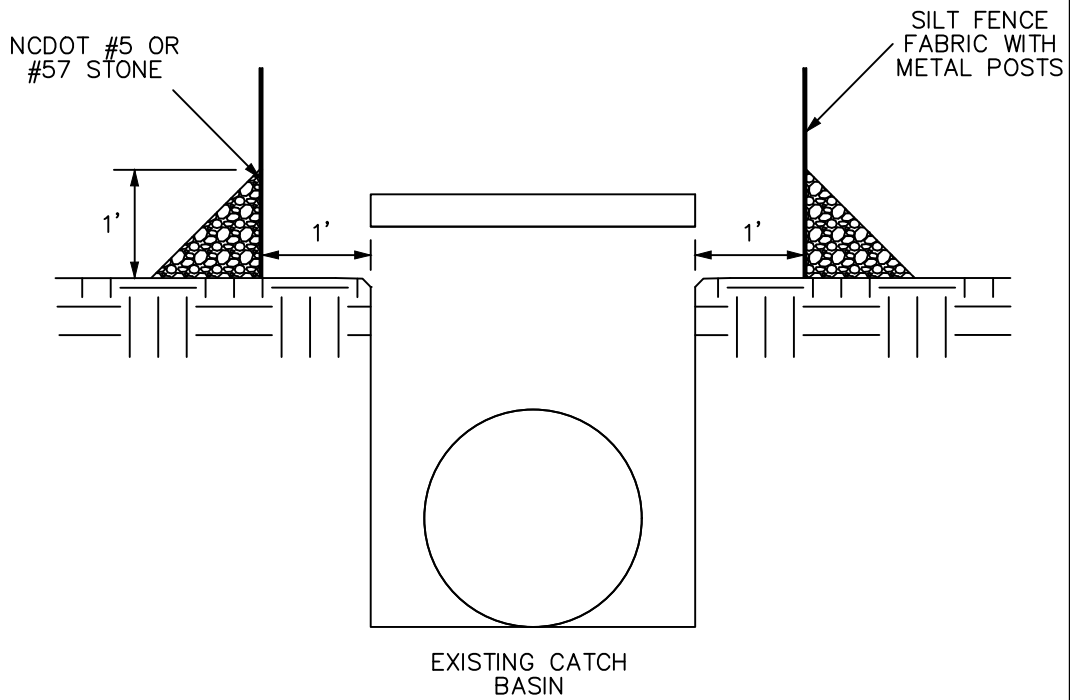
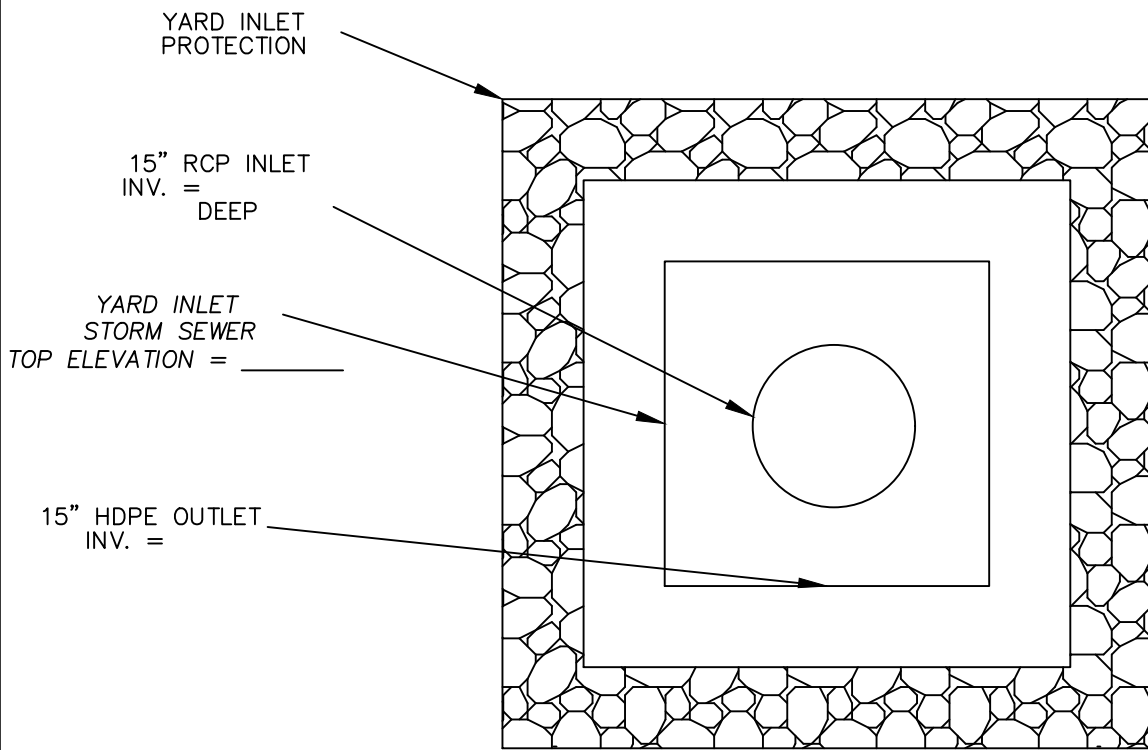

NOT TO SCALE



CITY OF HICKORY

YARD INLET PROTECTION

SHEET 1 OF 1

DATE:
2-1-07

STD. NO.
107

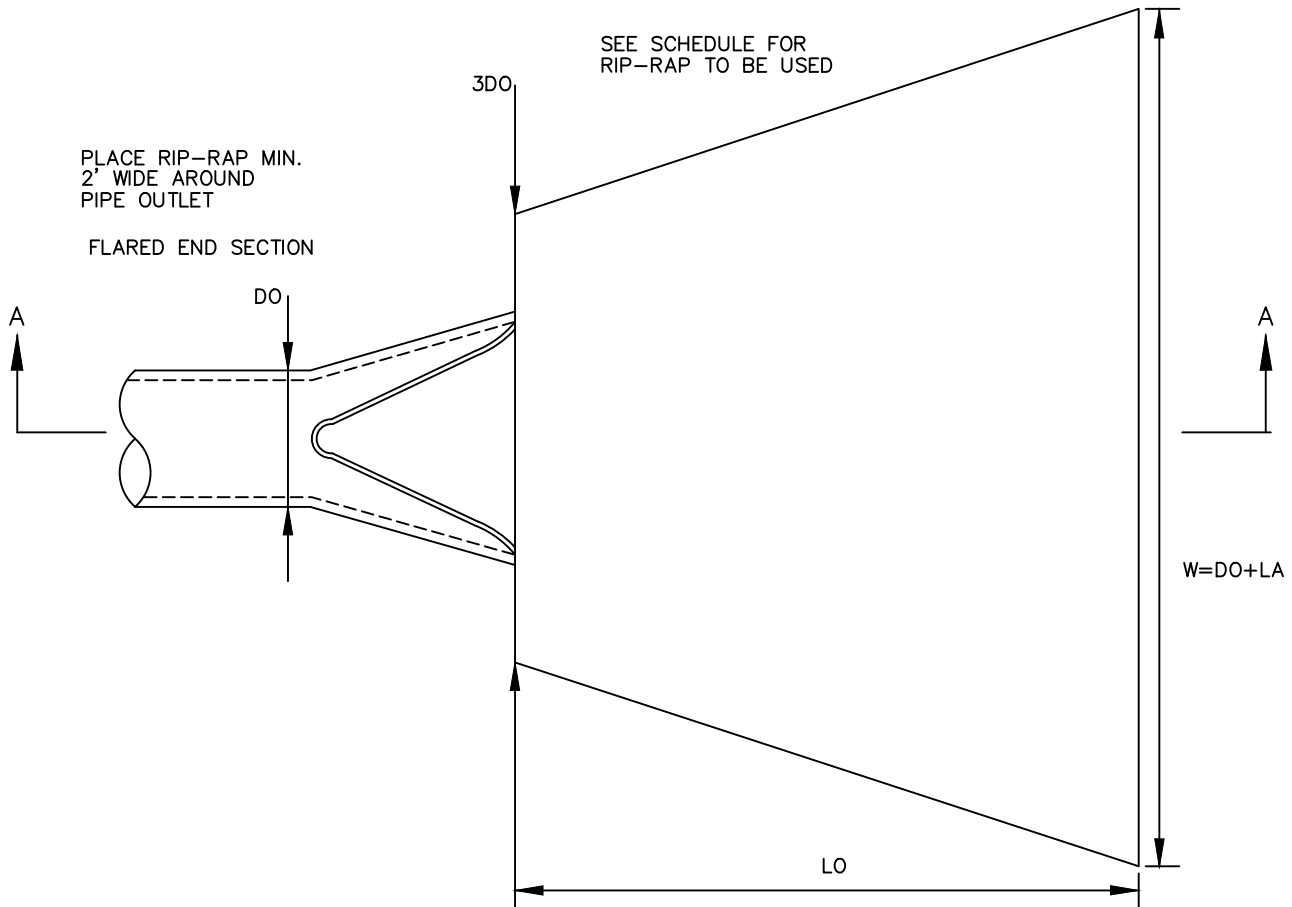

PLAN VIEW

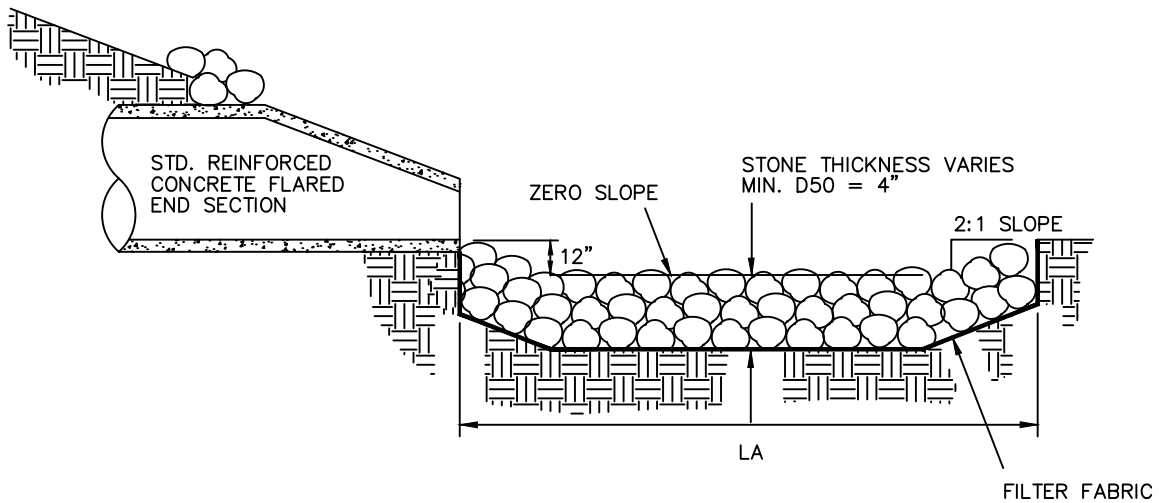

SECTION A-A

SIZE OF DISSIPATOR TO BE DETERMINED AS SHOWN IN SECTION 8.06 OF NCDEQ

NOT TO SCALE



CITY OF HICKORY

RIP-RAP OUTLET PROTECTION

SHEET 1 OF 1

DATE:
2-1-07

STD. NO.
108

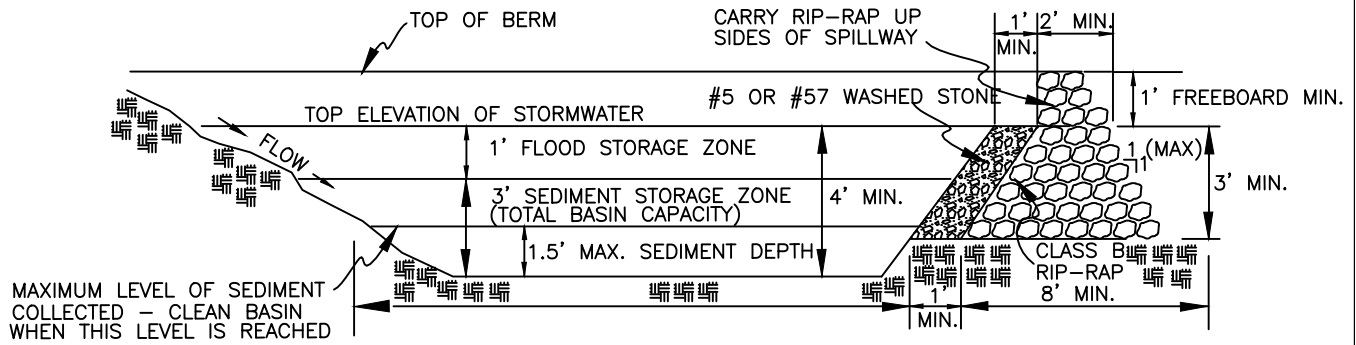

SECTION THRU BASIN & FILTER A-A
GRAVEL & RIP-RAP FILTER BASIN DETAIL

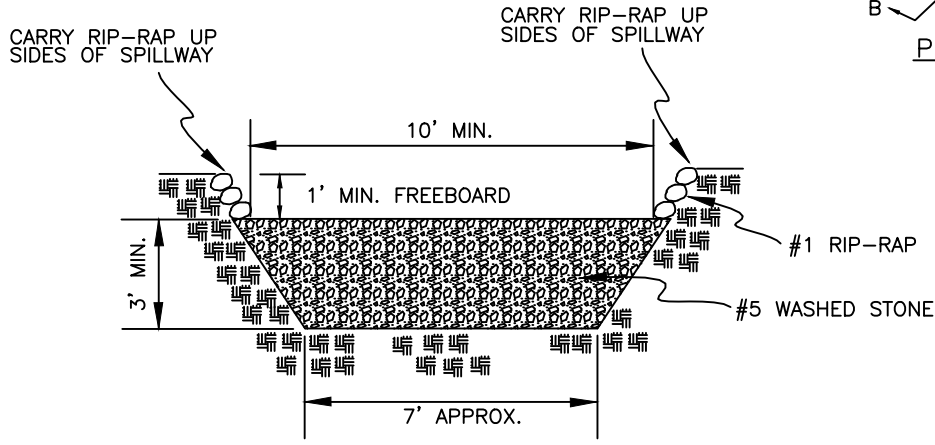
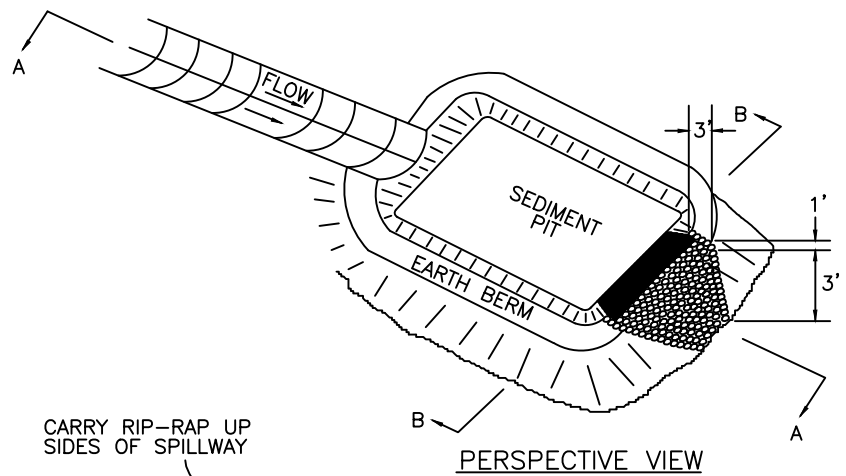

SECTION THRU BASIN & FILTER B-B

NOTE: THIS STRUCTURE MUST BE DESIGNED TO PASS THE 10-YEAR STORM WITHOUT OVERTOPPING THE EARTH BERM.

NOT TO SCALE



CITY OF HICKORY

TEMPORARY SEDIMENT TRAP

DATE:
2-1-07

SHEET 1 OF 1
STD. NO.
109

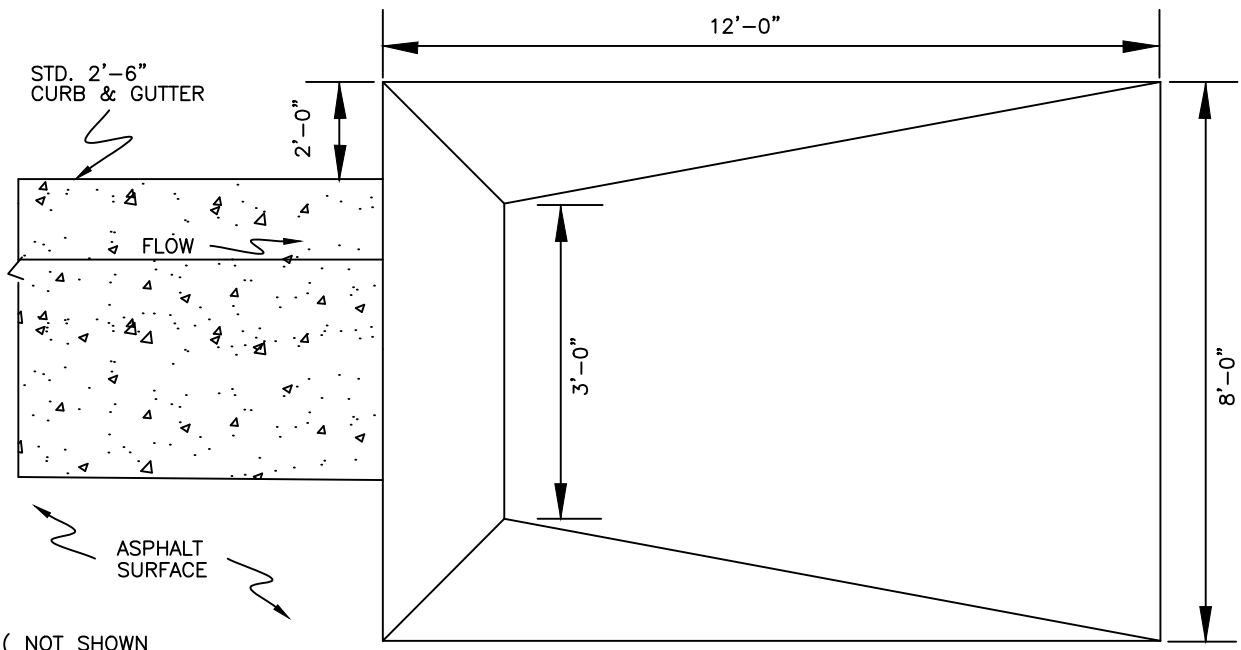

PLAN VIEW

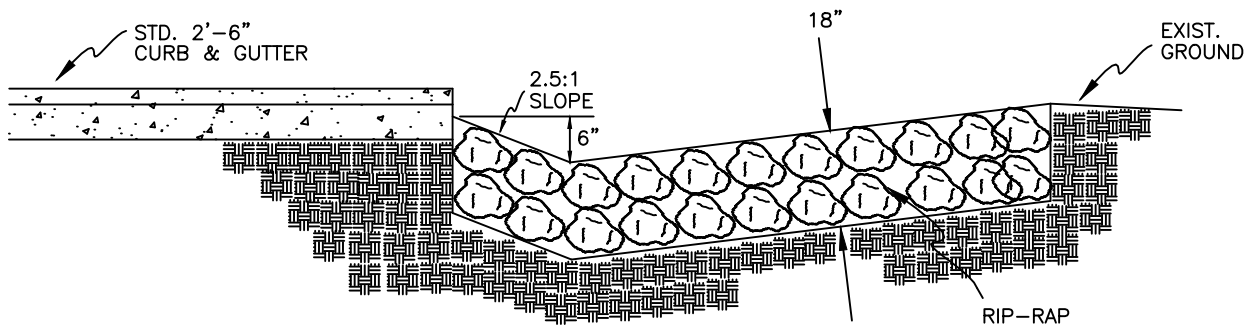

CLASS 1 RIP-RAP TO BE USED.

QUANTITY OF RIP-RAP REQUIRED FOR ONE GUTTER WILL BE 12 S.Y.

SECTION THROUGH DEVICE

NOT TO SCALE



CITY OF HICKORY
 DEAD END STREET
 EROSION CONTROL DEVICE

SHEET 1 OF 1

DATE:
2-1-07

STD. NO.
111

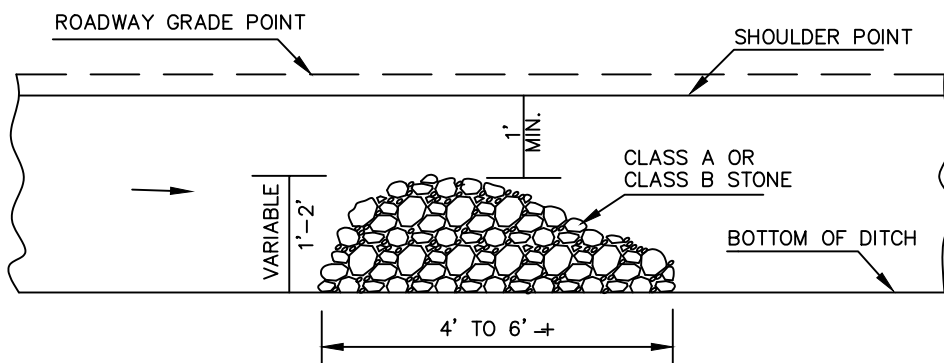
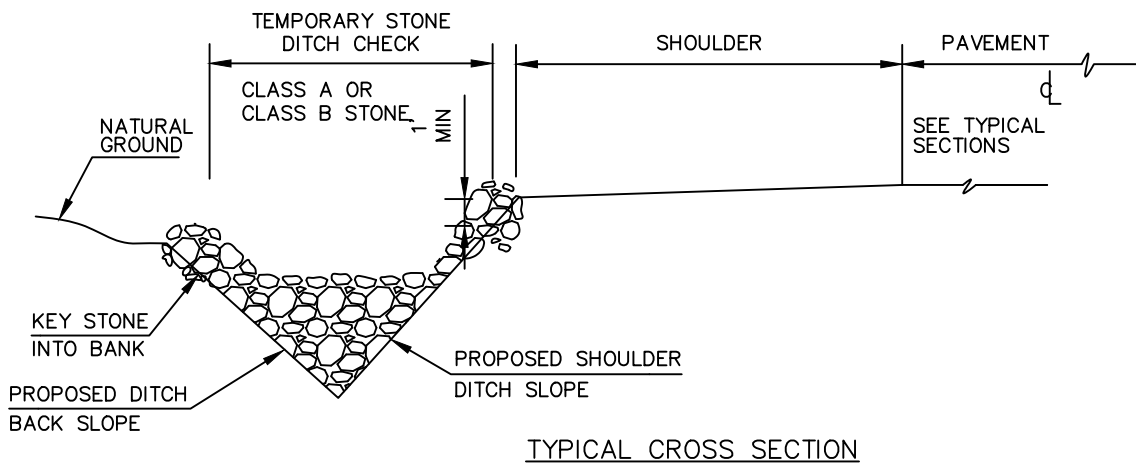
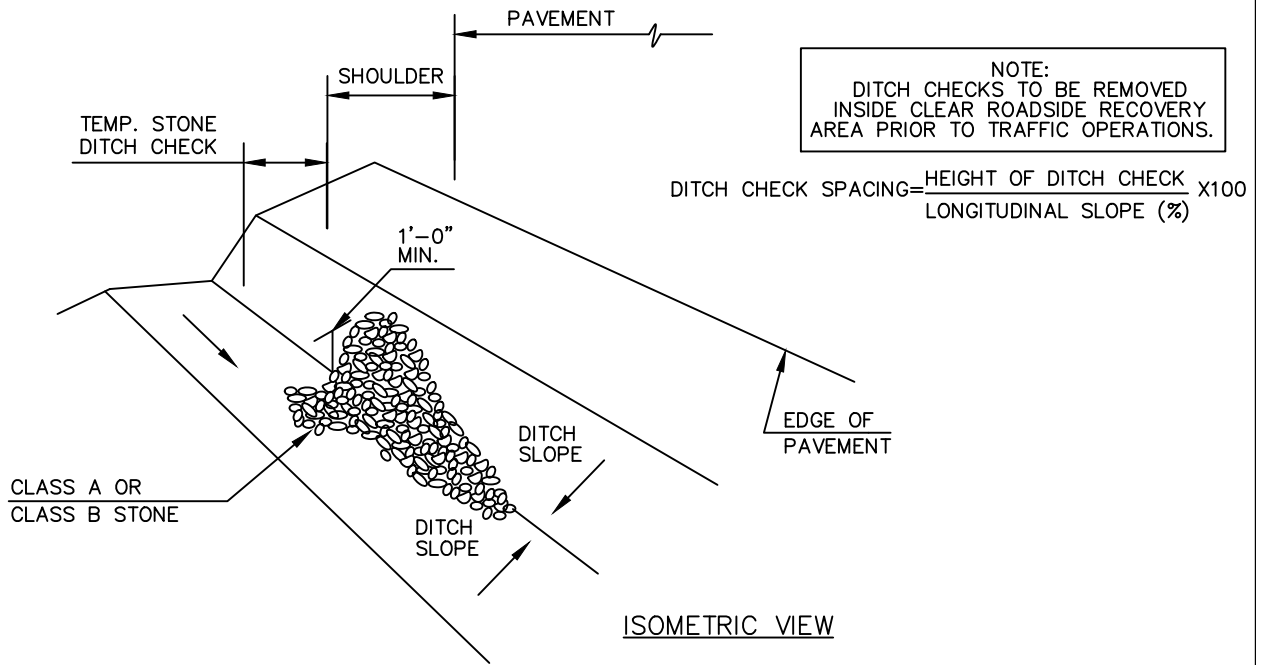

QUANTITY APPROXIMATELY 1 TO 2 TONS STONE

NOT TO SCALE



CITY OF HICKORY
TEMPORARY STONE
DITCH CHECK

SHEET 1 OF 1
DATE:
2-1-07
STD. NO.
112

*NOTE: SEE EROSION CONTROL PLAN FOR PIPE SIZE

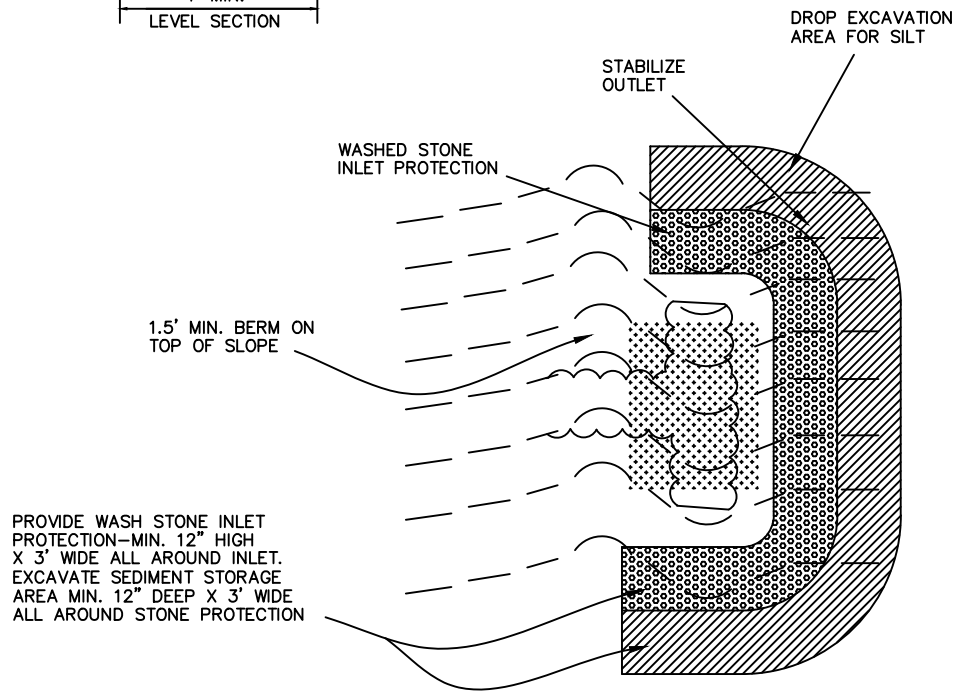
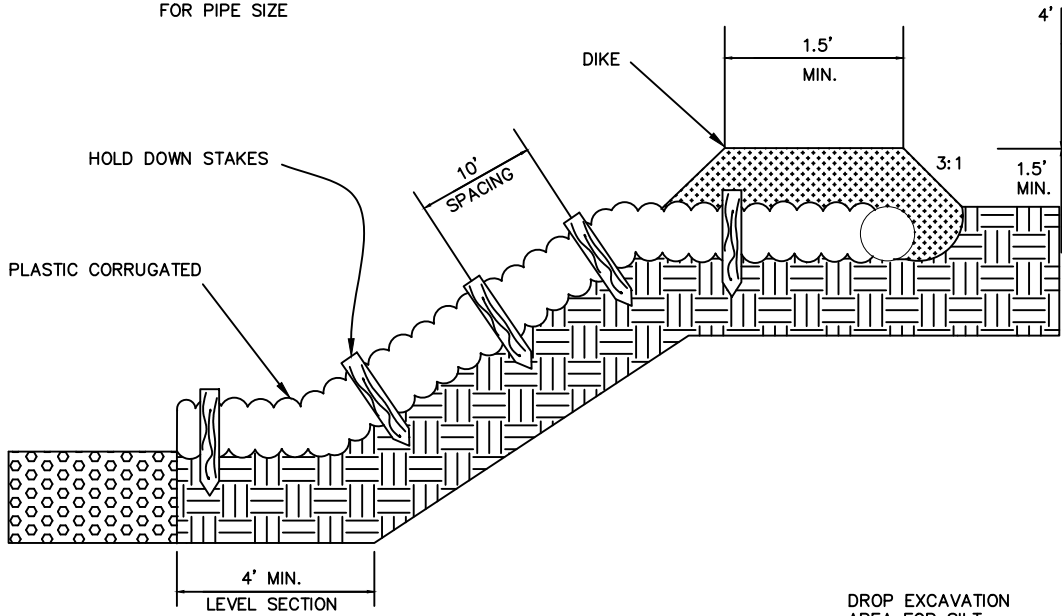

PROVIDE WASH STONE INLET PROTECTION—MIN. 12" HIGH X 3' WIDE ALL AROUND INLET. EXCAVATE SEDIMENT STORAGE AREA MIN. 12" DEEP X 3' WIDE ALL AROUND STONE PROTECTION

PLAN VIEW
STANDARD T-SECTION

NOT TO SCALE



CITY OF HICKORY
TEMPORARY SLOPE
DRAIN DETAIL

SHEET 1 OF 1

DATE:
2-1-07

STD. NO.
113

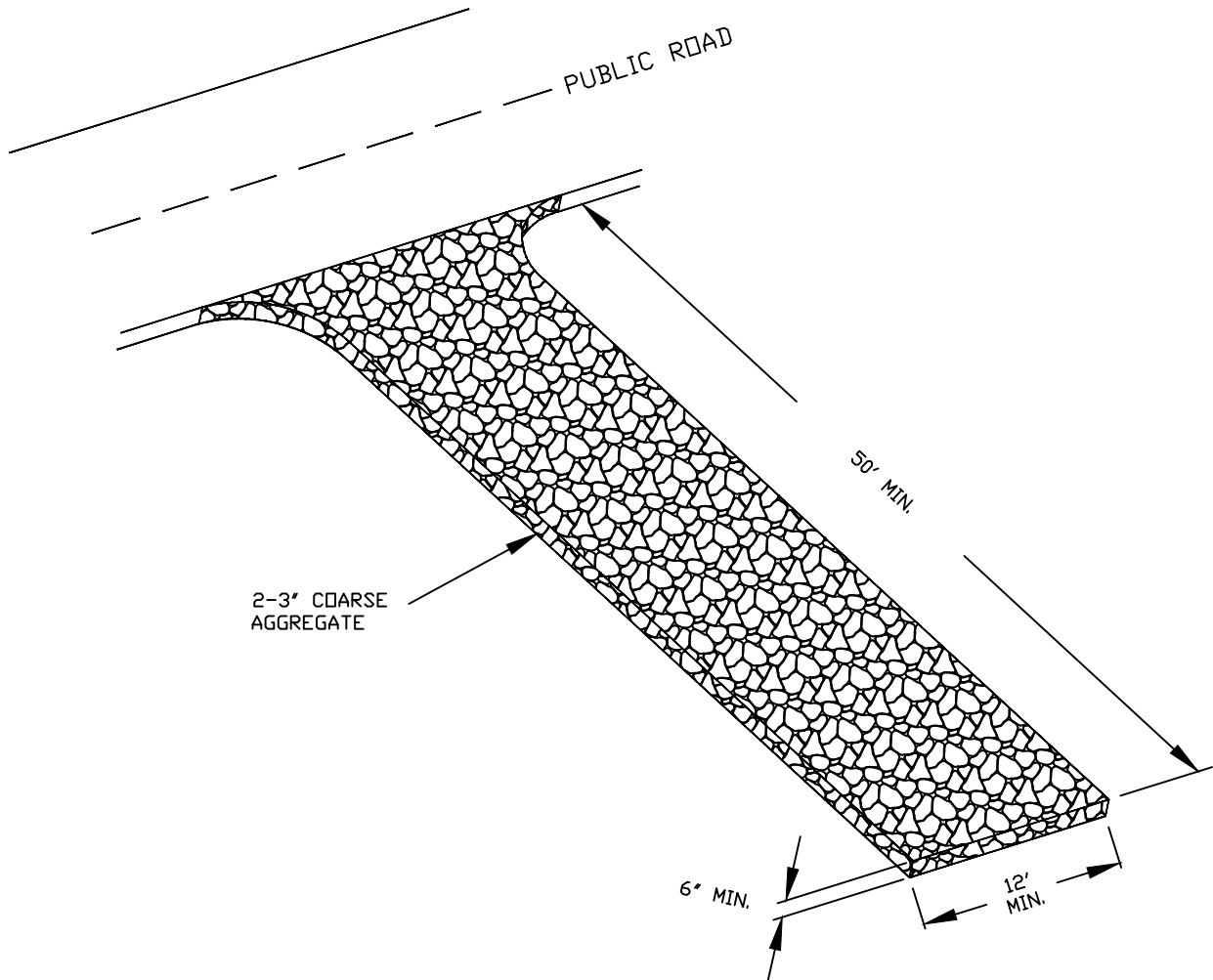

- NOTE:
1. TEMPORARY GRAVEL CONSTRUCTION ENTRANCE SHALL BE MAINTAINED TO REMOVE MUD & SOIL BUILDUP AFTER EACH RAIN EVENT AND AS NEEDED WHEN EFFECTIVENESS IS DIMINISHED
 2. ABC STONE IS NOT ACCEPTABLE

NOT TO SCALE



CITY OF HICKORY		SHEET 1 OF 1	
TEMPORARY GRAVEL CONSTRUCTION ENTRANCE		DATE: 2-1-07	STD. NO. 114

Engineering Department
Manual Of
Practice



Life. Well Crafted.

200 Drainage

DIVISION 200 DRAINAGE

A. GENERAL NOTES

1. All work and materials shall conform to the latest edition of the NCDOT Standard Specifications unless otherwise specified in this manual.
2. Only the following drainage pipe materials are allowed within the street right of way without prior approval by the City Engineer excluding driveway pipes:
 - (a) Class III reinforced concrete pipe.
 - (b) Fully bituminous coated corrugated steel or aluminum pipe with paved invert, minimum 14 gage.
 - (c) High density polyethylene (HDPE) pipe with corrugated exterior/smooth interior conforming to the requirements of AASHTO specification M294 for corrugated polyethylene pipe and shall require coupling bands and fittings and installed per manufacturers recommendations.
3. All driveway pipes within right of way must be approved by City Engineer.
4. All pipe shall be laid with the bell or groove up and the joint entirely interlocking.
5. Pipe used within the street right-of-way shall be a minimum diameter of eighteen (18) inches.
6. The minimum cover for all pipe is per the manufacturers recommendations but should not be less than two (2) feet. Special applications for less than two (2) feet of cover will be reviewed individually.
7. Concrete mortar joints shall be used for joining all concrete pipes. The pipe shall be clean and moist when mortar is applied. The lower portions of the bell or groove shall be filled with mortar sufficient to bring the inner surface flush and even when the next joint is fitted into place. The remainder of the joint shall then be filled with mortar and a bead or ring of mortar formed around the outside of the joint. The application of mortar may be delayed until fill is completed when the pipe is larger than thirty (30) inch.
8. Preformed joint sealer, which conforms to AASHTO specification M-198 for Type B flexible plastic gaskets, may be used in lieu of the mortar jointing method.
9. Coupling bands and fittings shall be used for joining all HDPE pipe. Coupling bands shall cover at least one full corrugation on each section of pipe. Gasket coupling bands are required between all pipe joints. The gasket shall be made of closed-cell synthetic expanded rubber meeting the requirements of ASTM D1056, Type 2. Gaskets shall be installed on the coupling band by the pipe manufacturer. All coupling bands shall meet or exceed the soil-tightness requirement of AASHTO Standard Specification for Highway Bridges, section 23, paragraph 23.1.5.4(e). Pipe fittings shall conform to AASHTO M252 or AASHTO M294.

10. The interior surfaces of all storm drainage structures shall be pointed up and smoothed to an acceptable standard using mortar mixed to manufacturer's specifications.

11. All pipes in storm drain structures shall be flush with the inside wall. All storm drain structures shall have hand-formed fillets to prevent standing water.

12. All storm drain structures, including pre-cast boxes, frames, grates, hoods, etc., shall meet current NCDOT standards. Refer to std. # 606 for requirements for steps.

13. Any storm drain structures over 3'-6" (three feet six inches) in height must have steps in accordance with standard details set forth in this manual.

14. All frames, grates, rings, covers etc., must conform to the standards set forth in this manual.

15. All graded creek banks and slopes shall be at a maximum of two (2) feet horizontal to one (1) foot vertical (2:1).

16. All backfill shall be non-plastic in nature, free from roots, vegetative matter, waste, construction material or other objectionable material. Said material shall be capable of being compacted by mechanical means and shall have no tendency to flow or behave in a plastic manner under the tamping blows or proof rolling.

17. Materials deemed by the Engineering Division as unsuitable for backfill purposes shall be removed and replaced with select backfill material.

18. Backfilling of trenches shall be accomplished immediately after the pipe is laid. The fill around the pipe shall be placed in layers not to exceed six (6) inches, each layer shall be thoroughly compacted to 95% of the maximum density obtainable with the Standard Proctor Test (a density of 100% Standard Proctor is required for the top eight (8) inches). All tests shall be provided by Contractor at no cost to the City.

19. Compaction requirements shall be attained by the use of mechanical compaction methods. Each layer of backfill shall be placed loose and thoroughly compacted in place.

20. Under no circumstances shall water be permitted to rise in unbackfilled trenches after the pipe has been placed.

B. STANDARDS FOR DESIGN

1. All storm drainage design shall conform with the standards and specifications as provided in the Land Development Code, or the more restrictive of any standards that conflict.

2. Adequate storm drainage shall be provided throughout the proposed development by means of storm drainage pipes or properly graded channels. All pipe shall be of adequate size and capacity, as approved by the City Engineer, to carry all storm water in its drainage area.



CITY OF HICKORY

GENERAL NOTES
FOR DRAINAGE

SHEET 2 OF 3

DATE:
2-1-07

STD. NO.
201

3. The City Engineer shall review the proposed drainage plan for compliance with the standards contained in the current edition of the Land Development Code and Manual of Practice and all other relevant and appropriate standards established by the City Engineering Department.

4. Sub-surface drainage shall be provided where the ground water level is likely to be near the surface. In capillary soils, the water level should be four (4) to six (6) feet below the surface to prevent the rise of moisture into the subgrade. Four (4) inch PVC or corrugated metal pipe with perforations shall be used to lower ground water in low areas in the street.

REFERENCES

1. North Carolina Department of Transportation, Standard Specifications for Roads and Structures, Latest Edition

2. American Association of State Highway and Transportation Officials, Latest Edition, A Policy on Geometric Design of Highways and Streets

3. North Carolina Department of Transportation, Roadway Design Manual, Latest Edition

4. North Carolina Department of Environment, Health, and Natural Resources, Erosion and Sediment Control Planning and Design Manual, Latest Edition

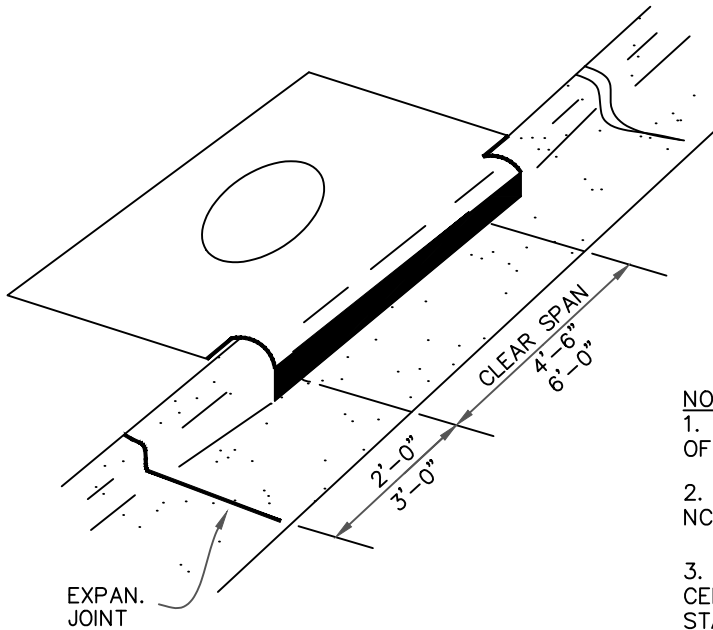

NOTES

1. BRICK MASONRY STRUCTURES MAY BE USED IN LIEU OF PRE-CAST CONCRETE

2. ALL DRAINAGE STRUCTURES SHALL MEET CURRENT NCDOT SPECIFICATIONS

3. FOR DEPTHS OVER 4'-0" USE STEPS ON 1'-3" CENTERS. STEPS SHALL BE IN ACCORDANCE WITH STANDARD #606

4. REFERENCE STANDARD 840.03 FRAME, GRATES, AND HOOD IN NCDOT STANDARDS

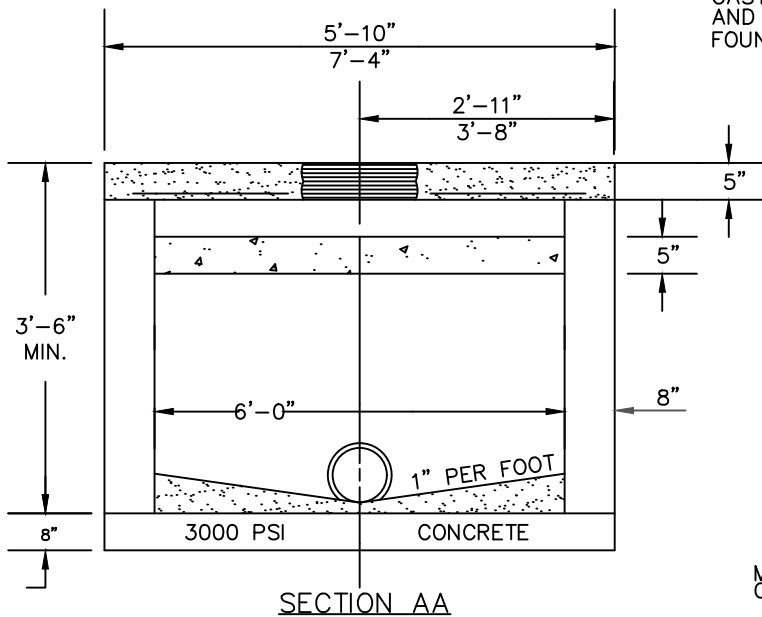
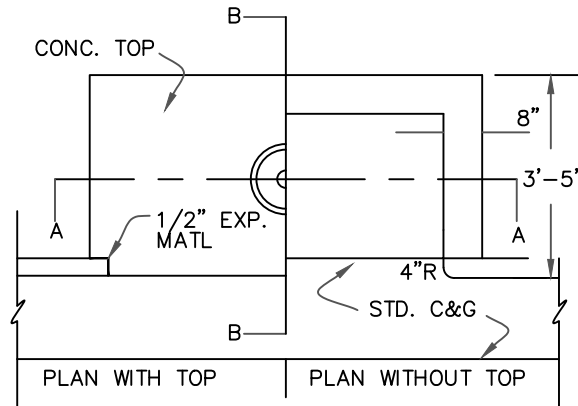

CAST-IN-PLACE RING AND COVER. REFER TO U.S. FOUNDRY 1161, OR EQUIVALENT

SEE SHEET 2 OF 2

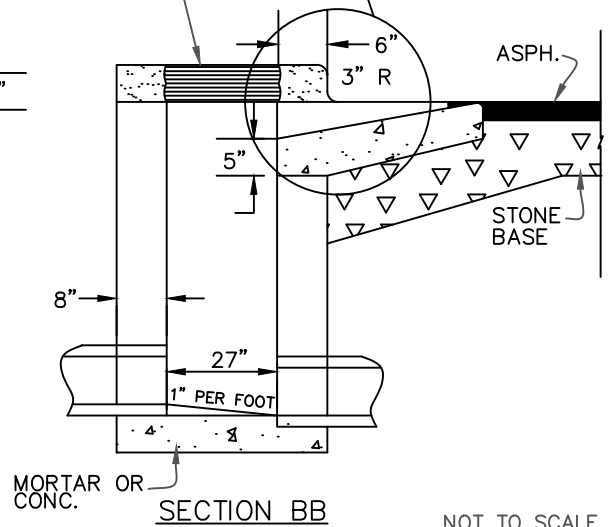

NOT TO SCALE



CITY OF HICKORY

CURB INLET

SHEET 1 OF 1

DATE:
2-1-07

STD. NO.
202

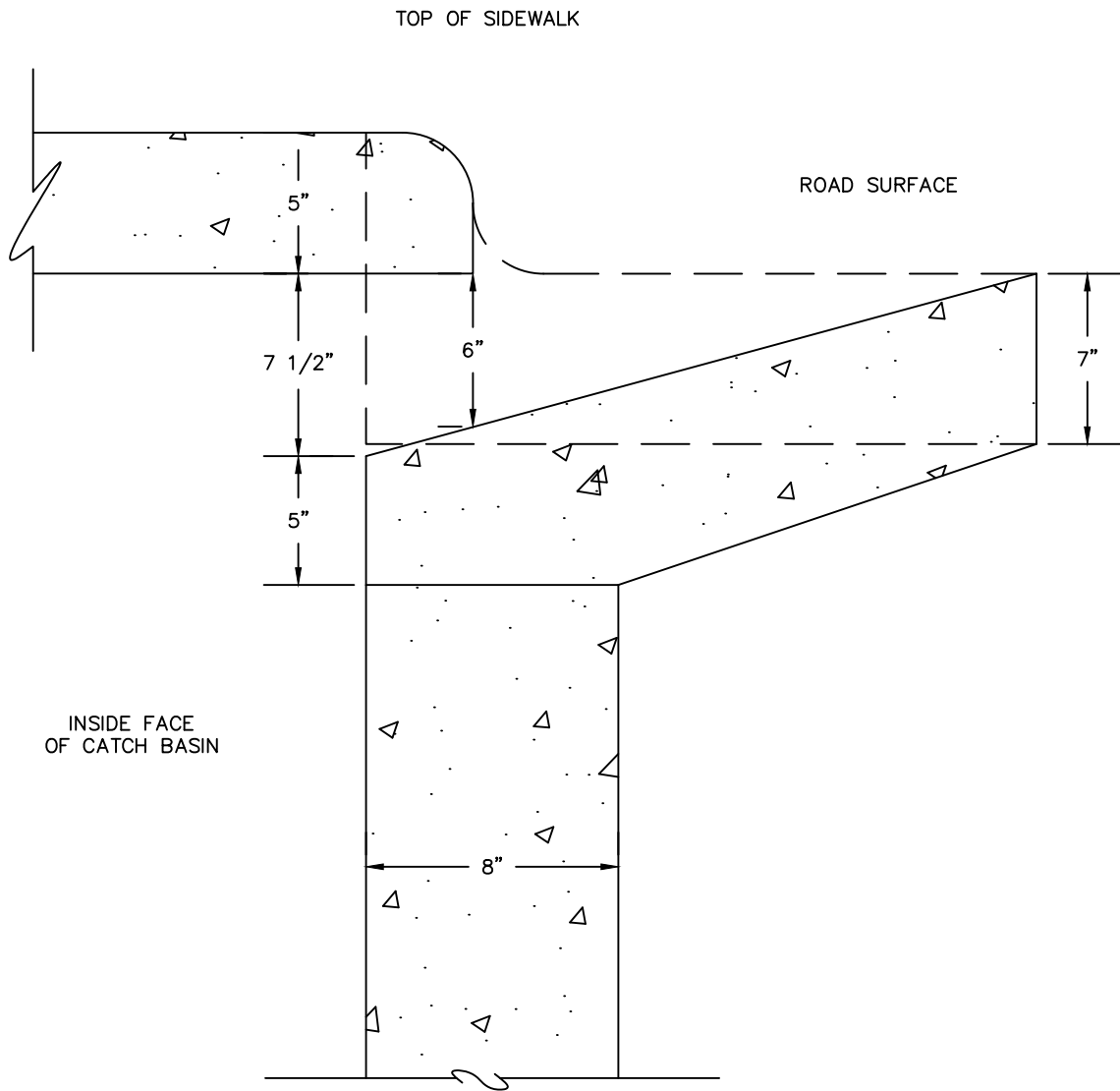

CUT THROUGH OF CURB INLET

NOT TO SCALE



CITY OF HICKORY
 CURB INLET THROAT FOR 2'-6"
 CURB & GUTTER

SHEET 1 OF 1

DATE:
 2-1-07

STD. NO.
 203

NOTES:
 CONCRETE SHALL BE 3000 PSI.
 TOP SHALL HAVE A SMOOTH FINISH.

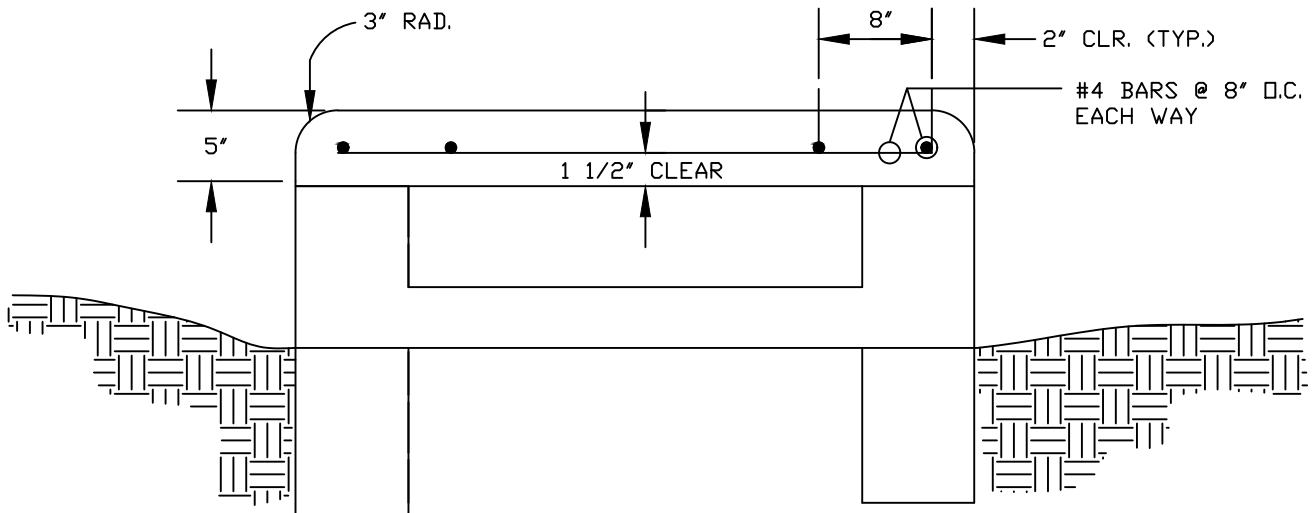
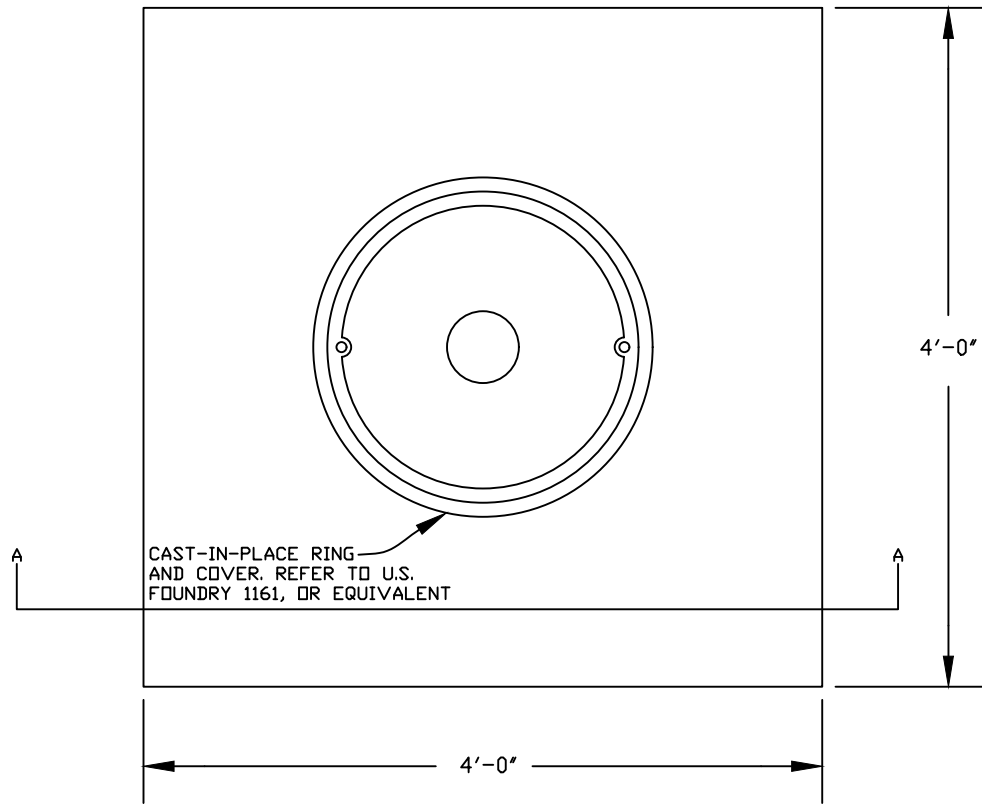

SECTION A-A

NOT TO SCALE



CITY OF HICKORY

4'x4' BRICK MASONRY YARD INLET

SHEET 1 OF 1

DATE:
2-1-07

STD. NO.
206

Engineering Department
Manual Of
Practice



Life. Well Crafted.

300 Streets

DIVISION 300 STREETS

A. GUIDELINES FOR CITY-MAINTAINED ROADS IN SUBDIVISIONS

- The road must be an obvious connection between city of state roads that would be useful as an alternate route of travel.
- Townhomes, apartment complexes, gated communities, and others similar, shall not be city-maintained roads.
- Traditional single family detached true subdivisions are more likely to be incorporated as a city-maintained road.
- Subdivisions with 99 or less units are allowed one entrance unless it crosses water whereupon it shall have a second entrance.
- Any subdivisions with 100 units or more shall have a minimum of two entrances.
- Ultimately, the decision whether a road is city-maintained or not is up to the discretion of the city planner, engineer, or traffic engineer.

B. GENERAL NOTES

A.1. All work and materials shall conform to the latest edition of the North Carolina Department of Transportation (NCDOT) Standard Specifications for Roads and Structures unless otherwise specified in this manual. In the event of a conflict between NC DOT Standard Specifications and the Manual of Practice, the more stringent shall apply.

A.2. The contractor shall maintain two-way traffic at all times when working within existing streets. The contractor shall place and maintain signs, danger lights, barricades and furnish watchmen or flagmen to direct traffic in accordance with the Manual for Uniform Traffic Control Devices (MUTCD).

A.3. The contractor shall provide all necessary erosion control measures and prevent sedimentation damage to all adjacent properties and streams in accordance with the appropriate City/County Soil Erosion and Sedimentation Control Ordinance. Standing water within the project limits during construction shall not be permitted.

A.4. No work shall begin until construction plans and specifications have been approved by the Engineering Division and Public Utilities as appropriate and a pre-construction conference has been held. All contractors and subcontractors shall have an approved set of plans at the jobsite at all times.

A.5. All testing shall be performed by a certified geotechnical laboratory approved by the City of Hickory. Copies of all test reports shall be signed and sealed by a Professional Engineer licensed in the state of North Carolina. The City of Hickory may choose to change testing requirements based on site conditions, contractor's competence, and actual quality of work performed. Refer to specific testing requirements in the following sections. The City of Hickory reserves the right to select test locations.

C. STANDARDS OF STREET DESIGN

1. PUBLIC STREETS:	LOCAL			COLLECTOR		
	Level	Rolling	Hilly	Level	Rolling	Hilly
a. Terrain Classification	0-8%	8.1-15%	15%+	0-8%	8.1-15%	15%+
b. Min. Sight Distance (ft.)	200	150	110	250	200	150
c. Maximum Grade	6%	10%	12%	4%	8%	10%
d. Design Speed (mph)	30	25	20	35	30	25
e. Minimum Radius (ft.)	250	150	90	350	250	175
f. Min. Tangent between Reverse Curves	50	50	50	100	100	100
g. K Values (crest/sag)	28/35	20/20	15/20	45/45	28/35	20/20

Note: Use of Hilly terrain criteria not permitted without prior approval of the City Engineer.

Any grade above 10% needs to be approved by the Fire Chief, Fire Marshal, and City Engineer



2. INTERSECTIONS

Intersection Properties	Level	Rolling	Hilly
a. Terrain Classification	0-8%	8.1-15%	15%+
b. Vert. Alignment within 50 ft. (of street intersection)	1%	3%	4%
c. Minimum Angle of Intersection	75°	75°	75°
d. Min. Curb & R/W Radius (ft.)			
1. Local	30	30	30
2. Collector	30	30	30
e. Min. Street Offsets for Adjacent Intersections (ft.)			
1. Local	125	125	125
2. Collector	200	200	200

Note: Use of Hilly terrain criteria not permitted without prior approval of the City Engineer.

1. Design criteria for arterial streets shall be established by the City Engineer on a case-by-case basis according to the latest edition of the American Association of State Highway and Transportation Officials (AASHTO) A Policy on Geometric Design of Highways and Streets and/or NCDOT Roadway Design Manual.

2. Intersection corner - 10'x 70' sight triangle shall be provided at intersections. Additional sight distance may be required by the NCDOT or the City of Hickory Transportation Division to meet sight conditions.

C. GRADING

C.1. Proposed street rights-of-way shall be graded to their full width as shown on appropriate cross sections. Roadways shall be constructed to the alignment and grades shown on the construction drawings.

C.2. Fill embankments shall be formed of suitable material placed in successive layers not to exceed more than six (6) inches in depth for the full width of the cross-section, including the width of the slope area. No stumps, trees, brush, rubbish, organic matter, or other unsuitable materials or substances shall be placed in the embankment. Each successive six (6) inch layer shall be thoroughly compacted by a sheepsfoot tamping roller, 10-ton (minimum) power roller, pneumatic-tired roller, or other methods approved by the City Engineer. Embankments over and around all pipe culverts shall be of select material, placed and thoroughly compacted as directed by the City Engineer or his representative. All fill materials within the embankment shall be placed in loose layers not to exceed six (6) inches in depth and compacted to 95% Standard Proctor. All material to a depth of eight (8) inches below the finished surface of the subgrade shall be compacted to a density equal to at least 98% Standard Proctor.

Compaction test shall be performed for all embankments at a minimum frequency of one (1) passing test per 100 L.F. of roadway per 18" soil depth. A minimum of three (3) passing tests shall be performed for any section of roadway. One (1) passing test shall be provided for each failing test.



CITY OF HICKORY

GENERAL NOTES
FOR STREETS

SHEET 2 OF 11

DATE:
2-1-07

STD. NO.
301

C.3. All backfill shall be non-plastic in nature, free from roots, vegetative matter, waste, construction material or other objectionable material. Said material shall be capable of being compacted by mechanical means and the material shall have no tendency to flow or behave in a plastic manner under the tamping blows or proof rolling.

C.4. Materials deemed by the Inspector as unsuitable for backfill purposes shall be removed and replaced with select backfill material.

C.5. All trenches in the street right-of-way shall be backfilled with suitable material immediately after the pipe is laid. **The fill around all pipe shall be placed in layers six (6) to nine (9) inches loose depth and each layer shall be compacted thoroughly.** Compaction tests shall be performed at a minimum of one (1) passing test per 250 L.F. per 18" soil depth. A minimum of three (3) passing tests shall be performed for any single run of trench. Trenches 4' off edge of pavement shall be compacted to 92% standard proctor. Trenches in right-of-way less than 4' from road surface shall be compacted to 95% of standard proctor.

C.6. Under no circumstances shall water be permitted to rise in unbackfilled trenches after the pipe has been placed.

C.7. The finished subgrade shall be proof-rolled before the Engineer certifies the subgrade. The City of Hickory shall witness all proof-rolling operations.

D. ROADWAY BASE COURSE

D.1. All roadways shall be improved with a base course to the required pavement width plus six (6) inches beyond each edge of pavement.

D.2. The material for stone base course shall conform to the requirements of Section 1010 of the NCDOT Standard Specifications. Construction methods shall conform to Section 520 of the NCDOT Standard Specifications. Test reports verifying compliance with NCDOT Standard Specifications shall be submitted and approved by the Engineering Division prior to placement of stone base.

D.3. The stone base shall be compacted to 100% of the maximum density as measured by the Modified Proctor Method by rolling with ring or tamping roller or with a pneumatic tired roller with a minimum weight of ten tons. When completed, the base course shall be smooth, hard, dense, unyielding, and well bonded.

D.4. In lieu of a stone base course, a bituminous concrete base course, type HB may be substituted. Construction shall conform to the requirements of Section 640 of the NCDOT Standard Specifications.

D.5. Bituminous concrete base course, type HB, shall be used in widening strips less than five (5) feet in width.

D.6. Engineer shall verify compacted stone base thickness and submit data with Engineer's Certification for Aggregate Base Course. A minimum of one (1) random sample shall be taken at intervals not to exceed 100 L.F. of roadway with a minimum of three (3) samples per single segment of roadway.

E. ROADWAY SURFACE

E.1. All roadways shall be improved with a surface course to the required width of the roadway as shown on the roadway typical section.

E.2. Plant mixed asphalt shall conform in all respects to Section 645 of the NCDOT Standard Specifications (9.5 C). A prime coat (tack coat) shall be applied when the base



CITY OF HICKORY

GENERAL NOTES
FOR STREETS

DATE:
9-8-22

SHEET 3 OF 11
STD. NO.
301

has been in place for seven (7) days or more. The compacted surface course shall not be less than two (2) inches thick.

E.3. Use of recycled asphalt shall be approved by City of Hickory prior to beginning of paving operation.

E.4. All asphalt cuts shall be made with a clean, neat cut when preparing street surfaces for patching or widening strips.

E.5. Paper joints shall be used to seal the ends of an asphalt pour.

E.6. When placing asphalt against existing surfaces, a straight edge shall be used to prevent "humping" at that location.

E.7. Stone shall be primed with a tack coat if paving is not complete within seven days following stone base approval.

E.8. Surfaces shall be tacked when asphalt is being placed over existing asphalt streets and adjoining concrete, storm-drain and sanitary sewer structures.

E.9. In rolling and hilly terrains, sweeping of the stone base and/or application of a tack coat may be required near intersections. These requirements shall be established by the City of Hickory based on field conditions.

E.10. The contractor/developer shall provide core sampling and testing of asphalt by a certified independent testing lab at no cost to the City. Core samples shall be taken at a frequency and location as established by the inspector, but not less than three (3) samples shall be taken. All asphalt shall have a minimum in-place density of 95% using Marshall Method. One (1) passing test shall be provided for each failing test.

E.11. A canvas cover or other suitable cover shall be required for transporting plant mix asphalt during cool weather or when the following conditions are present:

(a) Air temperature is below 60° F.

(b) Length of haul from plant to job is greater than five (5) miles.

(c) Other occasions at the Inspector's discretion when a combination of factors indicates that material should be covered in order to ensure proper placement temperature.

E.12. Ambient air temperature must be at least 50° F and rising before asphalt can be placed. Asphalt placement operations shall be suspended when the air temperature is 50° F and descending.

F. CONCRETE CURB AND GUTTER AND SIDEWALKS

F.1. All concrete shall have a minimum compressive strength of 3000 PSI at 28 days. The contractor shall prepare concrete test cylinders in accordance with Section 1000 of the NCDOT Standard Specifications at the direction of the project inspector. All testing equipment and cylinder molds shall be furnished by the contractor. It shall be the responsibility of the contractor to protect the cylinders until such time as they may be safely transported for testing. Testing for projects shall be performed by an independent testing lab at no cost to the City. The contractor shall provide equipment and perform tests on concrete for a maximum slump and air content as defined in Section 1000 of the NCDOT Standard Specifications. These tests shall be performed at a frequency established by the inspector. Materials failing to meet specifications shall be removed by the contractor.



CITY OF HICKORY

GENERAL NOTES FOR STREETS

SHEET 4 OF 11

DATE:
10-10-23

STD. NO.
301

F.2. All concrete shall be cured with 100% Resin Base, white pigmented curing compound which meets A.S.T.M. Specification C-309, Type 1, applied within 24 hours of placement of the concrete at a uniform rate at one (1) gallon to 400 square feet.

F.3. Straight forms shall not be used for forming curb and gutter and sidewalks in curves.

F.4. All excess concrete on the front edge (lip) of gutter shall be removed when curb and gutter is machine-extruded.

F.5. All curb and gutter shall be backfilled with soil approved by the Inspector within 72 hours after construction.

F.6. Concrete shall not be placed until the air temperature measured at the location of the concreting operation is at 35° F and rising by 10:00 A.M. Concrete operations should be suspended when the air temperature is 40° F and descending. The contractor shall protect freshly placed concrete in accordance with Section 420 of the NCDOT Standard Specifications when the air temperature is at or below 35° F and the concrete has not obtained an age of 72 hours.

F.7. All soil and mud stains on concrete shall be removed by Contractor after backfilling and seed and strawing operations are finished.

F.8. Concrete wasted during truck or mixer washing shall be placed in a location approved by the City Inspector. In no case shall waste concrete be dumped in or around storm drainage structures, creeks, utility appurtenances, or on asphalt surfaces.

F.9. Where concrete curb and gutter is installed, all water and sewer taps shall be designated by stamping a "W" or "S" respectively in the vertical face of the curb at the location of the tap. The letters shall have a maximum height of three (3) inches and a minimum height of two (2) inches. Minimum depth of letters into the concrete surface shall be ½ inch.

G. ENGINEER'S CERTIFICATIONS

A Professional Engineer licensed in the State of North Carolina shall provide certifications to the City of Hickory as follows:

1. **Roadway Sub-grade Certification:** Engineer shall certify that all embankments, drainage structures, trenches, slopes, and horizontal and vertical alignment are constructed in accordance with the plans and specifications before authorizing the placement of the Concrete Curb and Gutter or Aggregate Base Course.
2. **Concrete Curb and Gutter (where applicable):** Engineer shall certify that all concrete curb and gutter, sidewalks and handicap accessible ramps are installed in accordance with the plans and specifications before authorizing placement of Aggregate Base Course.
3. **Aggregate Base Course:** Engineer shall certify that aggregate base course is furnished, placed and compacted in accordance with the plans and specifications including but not limited to base course thickness and width, compaction and material specifications prior to authorizing the placement of Asphalt Intermediate and Surface Courses.
4. **Asphalt Intermediate / Surface Course:** Engineer shall certify that the asphalt intermediate / surface courses are furnished, placed, compacted and finished in accordance with the plans and specifications.
5. **Storm Water Certification:** Engineer shall certify that all storm water conveyance structures, retention and detention measures, temporary and permanent erosion control structures and permanent ground cover are installed in accordance with the plans, specifications, erosion control permit and storm water permit as required for this project.

The City of Hickory Engineering Division shall be notified at least 48 hours in advance of the Contractor beginning any roadway construction operations and before the Engineer submits certifications upon completion of construction. The Engineer shall submit each certification listed above on the forms

	CITY OF HICKORY	
	GENERAL NOTES FOR STREETS	SHEET 5 OF 11 DATE: 2-1-07 STD. NO. 301

included in this document. Engineer shall immediately notify the Engineering Division of any variance in the work from the plans and specifications and before any adjustments to the work are made.

H. WARRANTY

All materials, products and workmanship shall be guaranteed against defects in material or workmanship for a minimum period of **one (1) year from date of final acceptance**. The owner/developer responsible for the work shall be responsible for this guarantee.

G. FIRE CODE

For fire apparatus access, refer to the current North Carolina fire code.

REFERENCES

- 1. North Carolina Department of Transportation, Standard Specifications for Roads and Structures, Latest Edition**
- 2. American Association of State Highway and Transportation Officials, 1990, A Policy on Geometric Design of Highways and Streets**
- 3. North Carolina Department of Transportation, Roadway Design Manual, Latest Edition**
- 4. North Carolina Department of Environment, Health, and Natural Resources, Erosion and Sediment Control Planning and Design Manual, Latest Edition**
- 5. City of Hickory Land Development Code.**



CITY OF HICKORY

GENERAL NOTES
FOR STREETS

SHEET 6 OF 11

DATE:
9-8-22

STD. NO.
301

Project Name _____

ENGINEER'S CERTIFICATION FOR ROADWAY SUB-GRADE

_____ Partial _____ Final

I, _____, as a duly registered Professional Engineer in the State of North Carolina, have been authorized by the Permittee to observe (periodically, weekly, full time) the construction of the following project segments:

STREET NAME	BEGINNING STATION	ENDING STATION
	+	+
	+	+
	+	+
	+	+
	+	+
	+	+

I hereby state that, to the best of my abilities, due care and diligence was used in the observation of the construction such that the construction was observed to be built within substantial compliance and intent of the referenced approved plans and specifications and other supporting materials.

Signature _____

Date _____

Note: Additional pages may be used as needed.

Seal

The above Engineer's Certification must be completed and submitted to the address below. This project shall not be considered complete until this Engineer's Certification has been submitted. Any work performed prior to completion of this Engineer's Certification shall be at Owner's risk and may affect acceptance of the subdivision final plat.

CITY OF HICKORY
ENGINEERING DIVISION
P.O. BOX 398
HICKORY, NC 28603



CITY OF HICKORY

GENERAL NOTES
FOR STREETS

SHEET 7 OF 11

DATE:
2-1-07

STD. NO.
301

Project Name _____

**ENGINEER'S CERTIFICATION FOR CONCRETE CURB AND GUTTER AND
SIDEWALKS**

_____ Partial _____ Final

I, _____, as a duly registered Professional Engineer in the State of North Carolina, have been authorized by the Permittee to observe (periodically, weekly, full time) the construction of the following project segments:

STREET NAME	BEGINNING STATION	ENDING STATION
	+	+
	+	+
	+	+
	+	+
	+	+
	+	+

I hereby state that, to the best of my abilities, due care and diligence was used in the observation of the construction such that the construction was observed to be built within substantial compliance and intent of the referenced approved plans and specifications and other supporting materials.

Signature _____

Date _____

Note: Additional pages may be used as needed.

Seal

The above Engineer's Certification must be completed and submitted to the address below. This project shall not be considered complete until this Engineer's Certification has been submitted. Any work performed prior to completion of this Engineer's Certification shall be at Owner's risk and may affect acceptance of the subdivision final plat.

CITY OF HICKORY
ENGINEERING DIVISION
P.O. BOX 398



CITY OF HICKORY

GENERAL NOTES
FOR STREETS

SHEET 8 OF 11

DATE:
2-1-07

STD. NO.
301

Project Name _____

ENGINEER'S CERTIFICATION FOR AGGREGATE BASE COURSE

_____ Partial _____ Final

I, _____, as a duly registered Professional Engineer in the State of North Carolina, have been authorized by the Permittee to observe (periodically, weekly, full time) the construction of the following project segments:

STREET NAME	BEGINNING STATION	ENDING STATION
	+	+
	+	+
	+	+
	+	+
	+	+
	+	+

I hereby state that, to the best of my abilities, due care and diligence was used in the observation of the construction such that the construction was observed to be built within substantial compliance and intent of the referenced approved plans and specifications and other supporting materials.

Signature _____

Date _____

Note: Additional pages may be used as needed. Seal

The above Engineer's Certification must be completed and submitted to the address below. This project shall not be considered complete until this Engineer's Certification has been submitted. Any work performed prior to completion of this Engineer's Certification shall be at Owner's risk and may affect acceptance of the subdivision final plat.

CITY OF HICKORY
ENGINEERING DIVISION
P.O. BOX 398
HICKORY, NC 28603



Project Name _____

ENGINEER'S CERTIFICATION FOR ASPHALT COURSE(S)

_____ Partial _____ Final _____ Intermediate _____ Course Surface

I, _____, as a duly registered Professional Engineer in the State of North Carolina, have been authorized by the Permittee to observe (periodically, weekly, full time) the construction of the following project segments:

STREET NAME	BEGINNING STATION	ENDING STATION
	+	+
	+	+
	+	+
	+	+
	+	+
	+	+
	+	+

I hereby state that, to the best of my abilities, due care and diligence was used in the observation of the construction such that the construction was observed to be built within substantial compliance and intent of the referenced approved plans and specifications and other supporting materials.

Signature _____

Date _____

Note: Additional pages may be used as needed.

Seal

The above Engineer's Certification must be completed and submitted to the address below. This project shall not be considered complete until this Engineer's Certification has been submitted. Any work performed prior to completion of this Engineer's Certification shall be at Owner's risk and may affect acceptance of the subdivision final plat.

CITY OF HICKORY
ENGINEERING DIVISION
P.O. BOX 398
HICKORY, NC 28603



CITY OF HICKORY

GENERAL NOTES
FOR STREETS

SHEET 10 OF 11

DATE:
2-1-07

STD. NO.
301

Project Name _____

ENGINEER'S CERTIFICATION FOR STORM WATER SYSTEM

_____ Partial _____ Final

I, _____, as a duly registered Professional Engineer in the State of North Carolina, have been authorized by the Permittee to observe (periodically, weekly, full time) the construction of the following project segments:

STREET NAME	BEGINNING STATION	ENDING STATION
	+	+
	+	+
	+	+
	+	+
	+	+
	+	+

I hereby state that, to the best of my abilities, due care and diligence was used in the observation of the construction such that the construction was observed to be built within substantial compliance and intent of the referenced approved plans and specifications and other supporting materials.

Signature _____

Date _____

Note: Additional pages may be used as needed.

Seal

The above Engineer's Certification must be completed and submitted to the address below. This project shall not be considered complete until this Engineer's Certification has been submitted. Any work performed prior to completion of this Engineer's Certification shall be at Owner's risk and may affect acceptance of the subdivision final plat.

CITY OF HICKORY
ENGINEERING DIVISION
P.O. BOX 398
HICKORY, NC 28603



CITY OF HICKORY

GENERAL NOTES
FOR STREETS

DATE:
2-1-07

SHEET 11 OF 11
STD. NO.
301

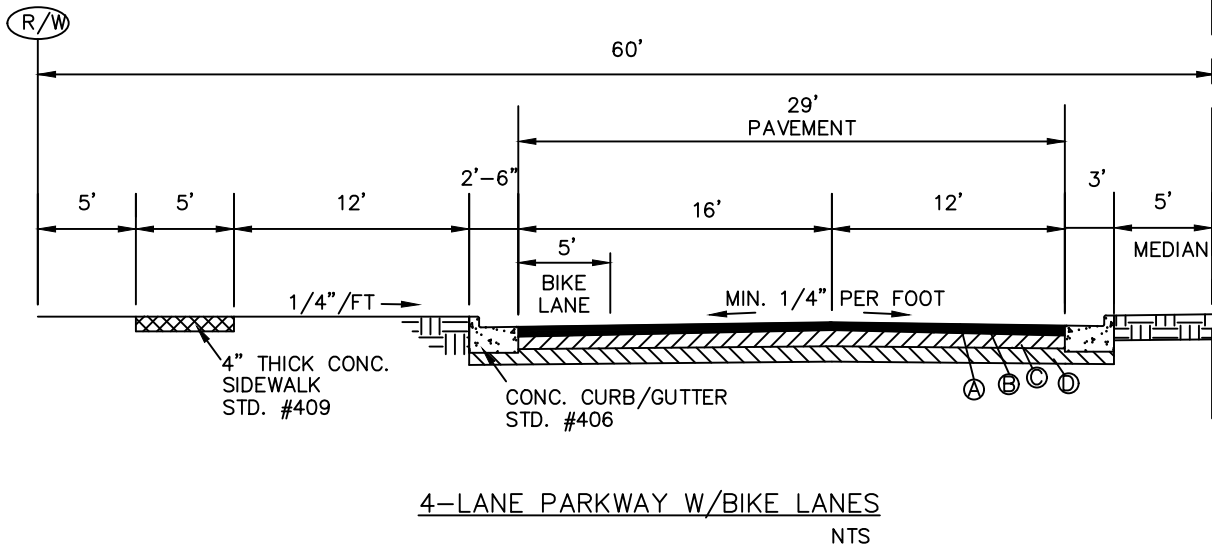
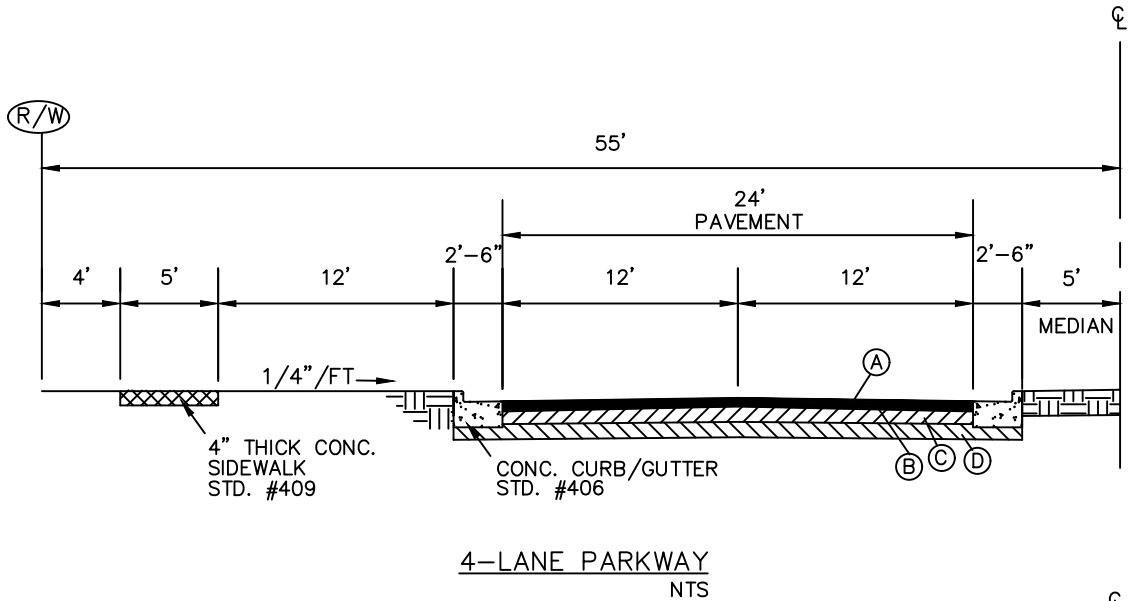

PAVEMENT SCHEDULE

- Ⓐ 2" BITUMINOUS CONCRETE SURFACE COURSE, TYPE S9.5C TO BE PLACED IMMEDIATELY UPON FINAL PREPARATION OF BINDER COURSE.
- Ⓑ FULL COVER TACK COAT
- Ⓒ 2" BITUMINOUS CONCRETE I19.0C COURSE TO BE PLACED IMMEDIATELY UPON FINAL PREPARATION OF ABC STONE BASE.
- Ⓓ 8" COMPACTED AGGREGATE BASE COURSE, COMPACTED TO 100% OF MAXIMUM DENSITY

NOTE: ALL WORK AND MATERIALS SHALL MEET N.C.D.O.T. STANDARDS AND SPECIFICATIONS

NOTE: CROSS SECTIONS ARE SYMMETRICAL ABOUT THE CENTER LINE

NOT TO SCALE



CITY OF HICKORY
 PARKWAY
 CROSS-SECTIONS

SHEET 1 OF 1
 DATE: 9-8-22
 STD. NO. 302

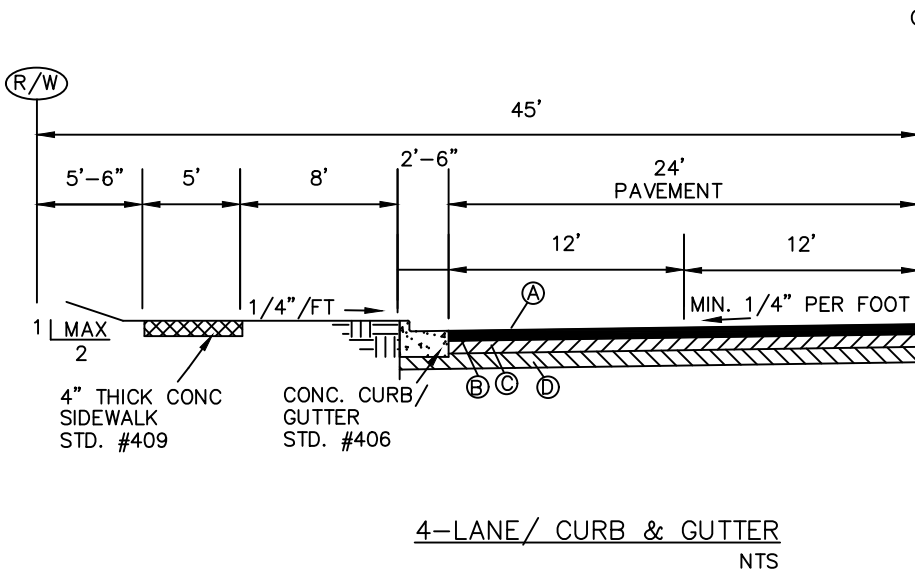

PAVEMENT SCHEDULE

- Ⓐ 2" BITUMINOUS CONCRETE SURFACE COURSE, TYPE S9.5C TO BE PLACED IMMEDIATELY UPON FINAL PREPARATION OF BINDER COURSE.
- Ⓑ FULL COVER TACK COAT
- Ⓒ 2" BITUMINOUS CONCRETE I19.0C COURSE TO BE PLACED IMMEDIATELY UPON FINAL PREPARATION OF ABC STONE BASE.
- Ⓓ 8" COMPACTED AGGREGATE BASE COURSE, COMPACTED TO 100% OF MAXIMUM DENSITY

NOTE: ALL WORK AND MATERIALS SHALL MEET N.C.D.O.T. STANDARDS AND SPECIFICATIONS

NOTE: CROSS SECTIONS ARE SYMMETRICAL ABOUT THE CENTER LINE

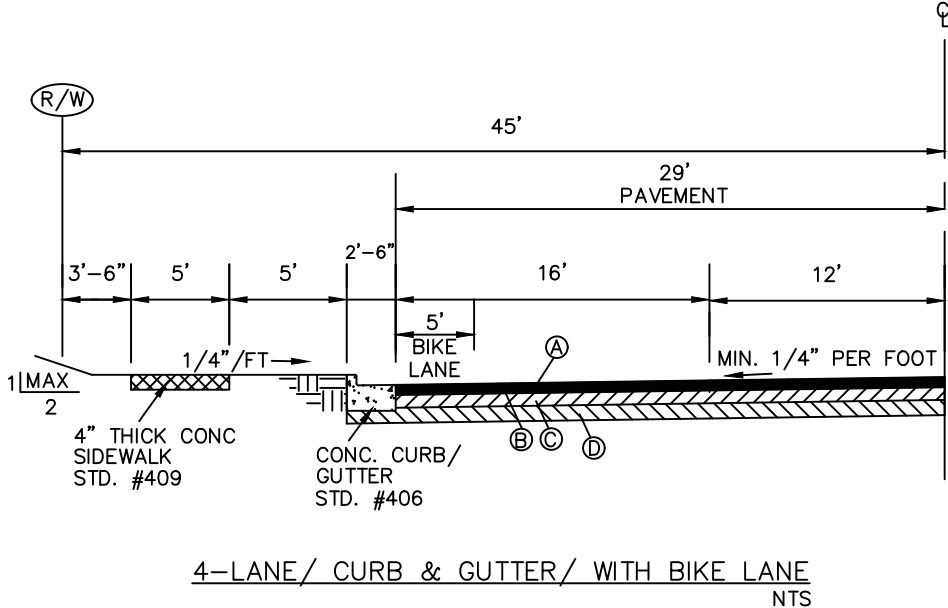
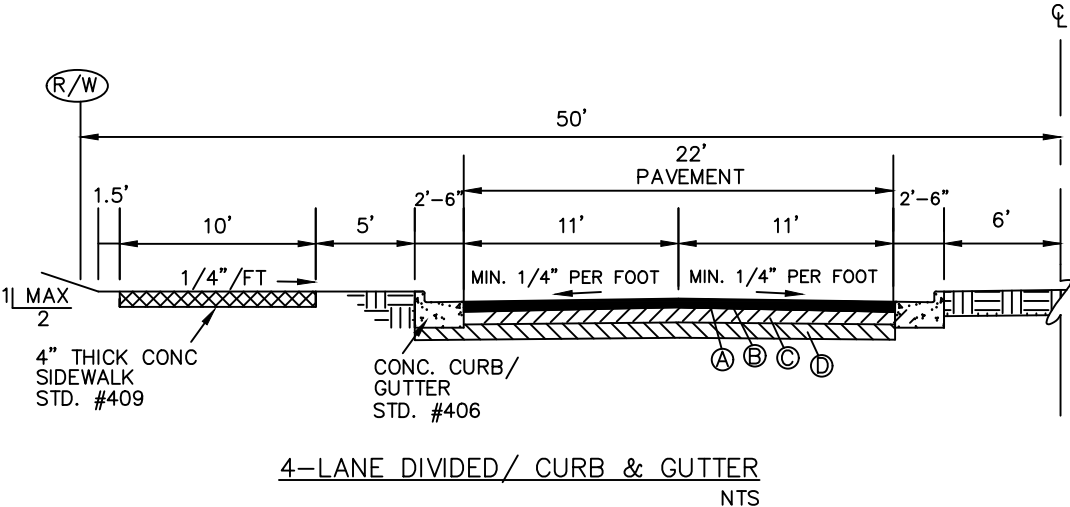

NOT TO SCALE



CITY OF HICKORY
ARTERIAL STREET
CROSS-SECTIONS

DATE: 9-8-22	SHEET 1 OF 1 STD. NO. 303
-----------------	---------------------------------

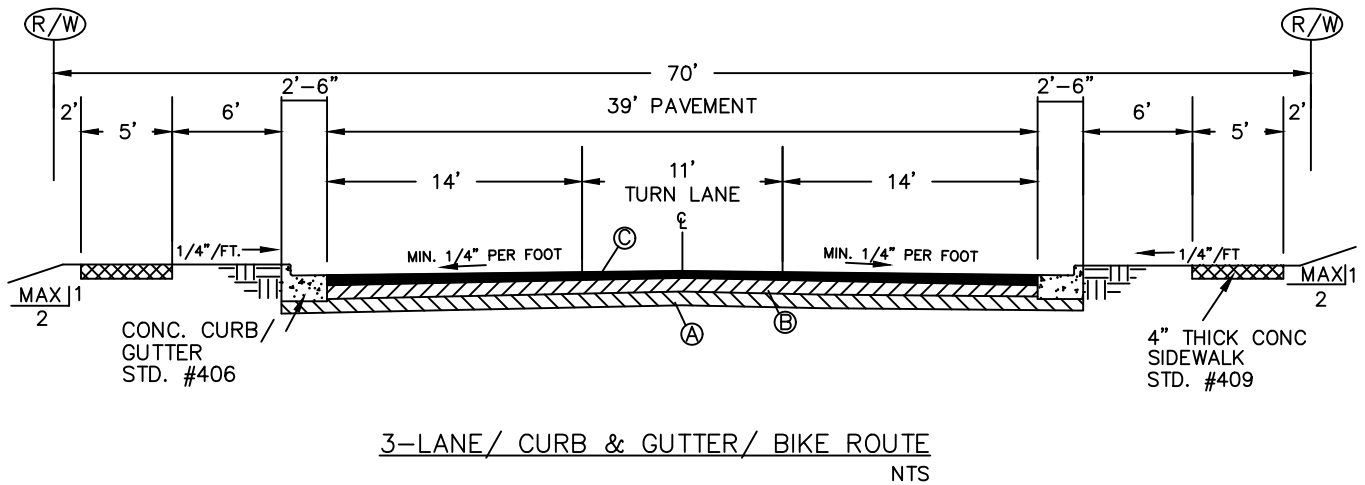
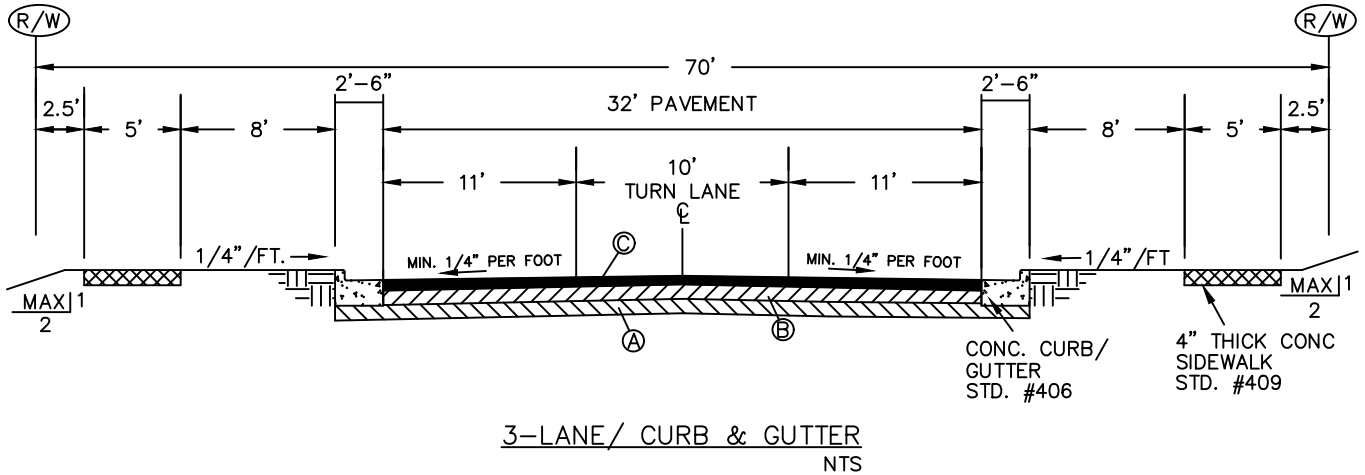

PAVEMENT SCHEDULE

- Ⓐ 8" COMPACTED AGGREGATE BASE COURSE
- Ⓑ 2" BITUMINOUS CONCRETE 119.0C COURSE TO BE PLACED IMMEDIATELY UPON FINAL PREPARATION OF ABC STONE BASE. PLANT MIX TO MEET N.C.D.O.T. SPECIFICATIONS.
- Ⓒ 2" BITUMINOUS CONCRETE SURFACE COURSE, TYPE S9.5C TO BE PLACED FOLLOWING PLACEMENT OF H-BINDER COURSE.

NOTE: ALL WORK AND MATERIALS SHALL MEET N.C.D.O.T. STANDARDS AND SPECIFICATIONS

NOTE: CROSS SECTIONS ARE SYMMETRICAL ABOUT THE CENTER LINE

NOT TO SCALE



CITY OF HICKORY

COLLECTOR STREET
CROSS-SECTIONS

SHEET 1 OF 1	
DATE: 10-10-23	STD. NO. 304

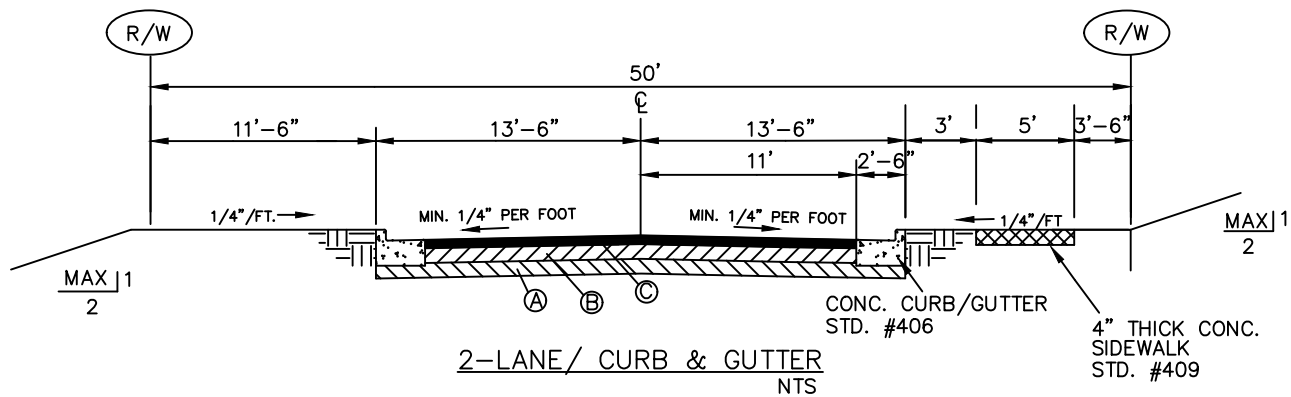

2-LANE/ CURB & GUTTER
NTS

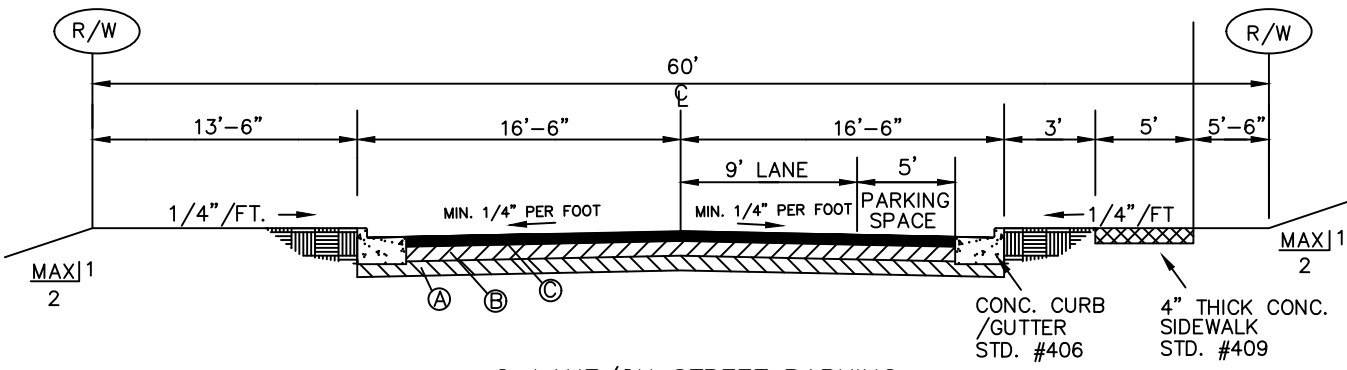

2-LANE/ON STREET PARKING
NTS

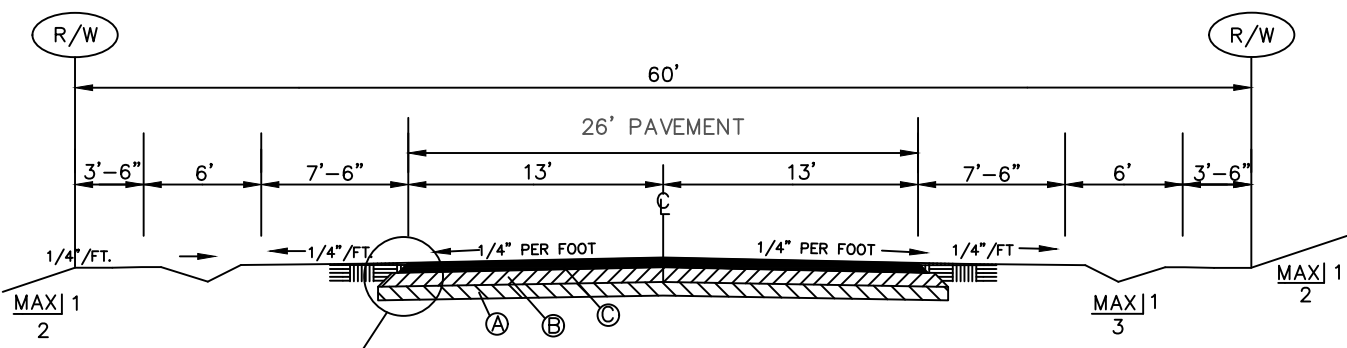

2-LANE/ DRAINAGE SWALE
NTS

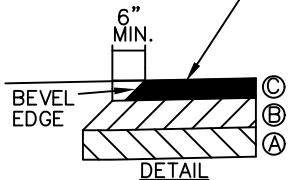

NOTE: ALL WORK AND MATERIALS SHALL MEET N.C.D.O.T. STANDARDS AND SPECIFICATIONS

PAVEMENT SCHEDULE

- (A) 6" COMPACTED AGGREGATE BASE COURSE
- (B) 2" BITUMINOUS CONCRETE I19.0C COURSE TO BE PLACED IMMEDIATELY UPON FINAL PREPARATION OF ABC STONE BASE. PLANT MIX TO MEET N.C.D.O.T. SPECIFICATIONS.
- (C) 2" BITUMINOUS CONCRETE SURFACE COURSE, TYPE S9.5C TO BE PLACED FOLLOWING PLACEMENT OF H-BINDER COURSE.

NOT TO SCALE



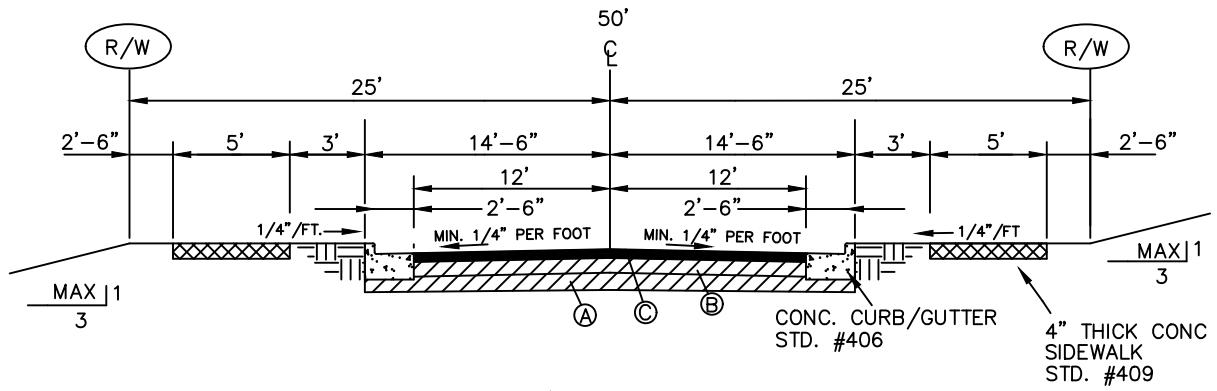

2-LANE / CURB & GUTTER
NTS

NOTE: FOR COMMERCIAL/INDUSTRIAL APPLICATIONS, SIDEWALK SHALL BE PROVIDED ON BOTH SIDES OF THE ROAD.

PAVEMENT SCHEDULE

- Ⓐ 8" COMPACTED AGGREGATE BASE COURSE
- Ⓑ 2" BITUMINOUS CONCRETE 119.0C COURSE TO BE PLACED IMMEDIATELY UPON FINAL PREPARATION OF ABC STONE BASE. PLANT MIX TO MEET N.C.D.O.T. SPECIFICATIONS.
- Ⓒ 2" BITUMINOUS CONCRETE SURFACE COURSE, TYPE S9.5C TO BE PLACED FOLLOWING PLACEMENT OF H-BINDER COURSE.

NOTE: ALL WORK AND MATERIALS SHALL MEET N.C.D.O.T. STANDARDS AND SPECIFICATIONS

NOT TO SCALE



CITY OF HICKORY

COMMERCIAL / INDUSTRIAL
STREET CROSS-SECTIONS

SHEET 2 OF 3

DATE:
9-8-22

STD. NO.
305

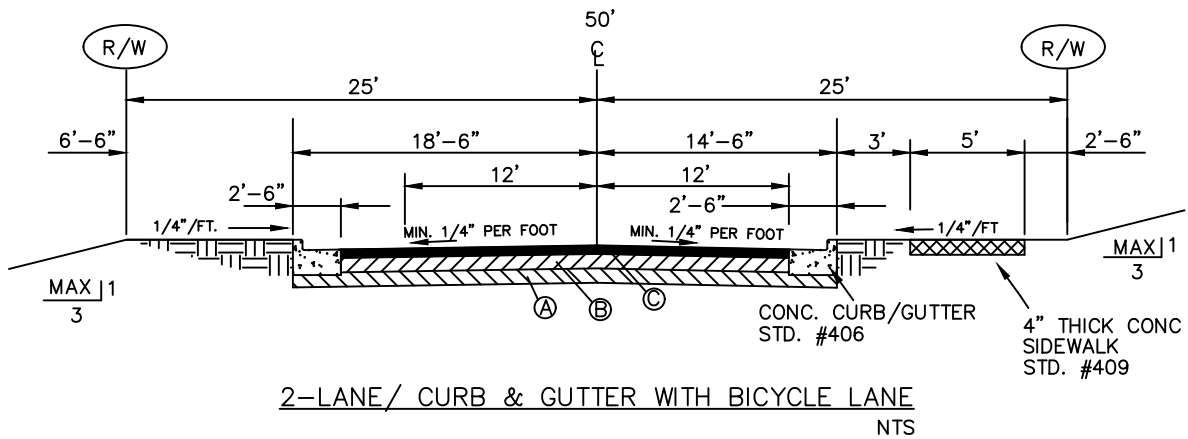

PAVEMENT SCHEDULE

- Ⓐ 6" COMPACTED AGGREGATE BASE COURSE
- Ⓑ 2" BITUMINOUS CONCRETE I19.0C COURSE TO BE PLACED IMMEDIATELY UPON FINAL PREPARATION OF ABC STONE BASE. PLANT MIX TO MEET N.C.D.O.T. SPECIFICATIONS.
- Ⓒ 2" BITUMINOUS CONCRETE SURFACE COURSE, TYPE S9.5C TO BE PLACED FOLLOWING PLACEMENT OF H-BINDER COURSE.

NOTE: ALL WORK AND MATERIALS SHALL MEET N.C.D.O.T. STANDARDS AND SPECIFICATIONS

NOT TO SCALE



CITY OF HICKORY		SHEET 3 OF 3
LOCAL STREET CROSS-SECTION		DATE: 10-10-23
		STD. NO. 305

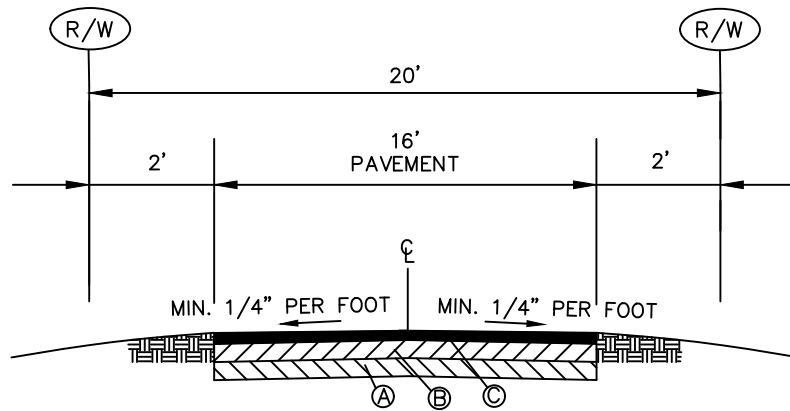

ALLEY
NTS

PAVEMENT SCHEDULE

- Ⓐ 6" COMPACTED AGGREGATE BASE COURSE
- Ⓑ 2" BITUMINOUS CONCRETE (19.0C) COURSE TO BE PLACED IMMEDIATELY UPON FINAL PREPARATION OF ABC STONE BASE. PLANT MIX TO MEET N.C.D.O.T. SPECIFICATIONS.
- Ⓒ 2" BITUMINOUS CONCRETE SURFACE COURSE, TYPE S9.5C TO BE PLACED FOLLOWING PLACEMENT OF H-BINDER COURSE.

NOTE: ALL WORK AND MATERIALS SHALL MEET N.C.D.O.T. STANDARDS AND SPECIFICATIONS

NOTE: CROSS SECTIONS ARE SYMMETRICAL ABOUT THE CENTER LINE

NOT TO SCALE



CITY OF HICKORY

ALLEY
CROSS-SECTION

SHEET 1 OF 1

DATE:
10-10-23

STD. NO.
306

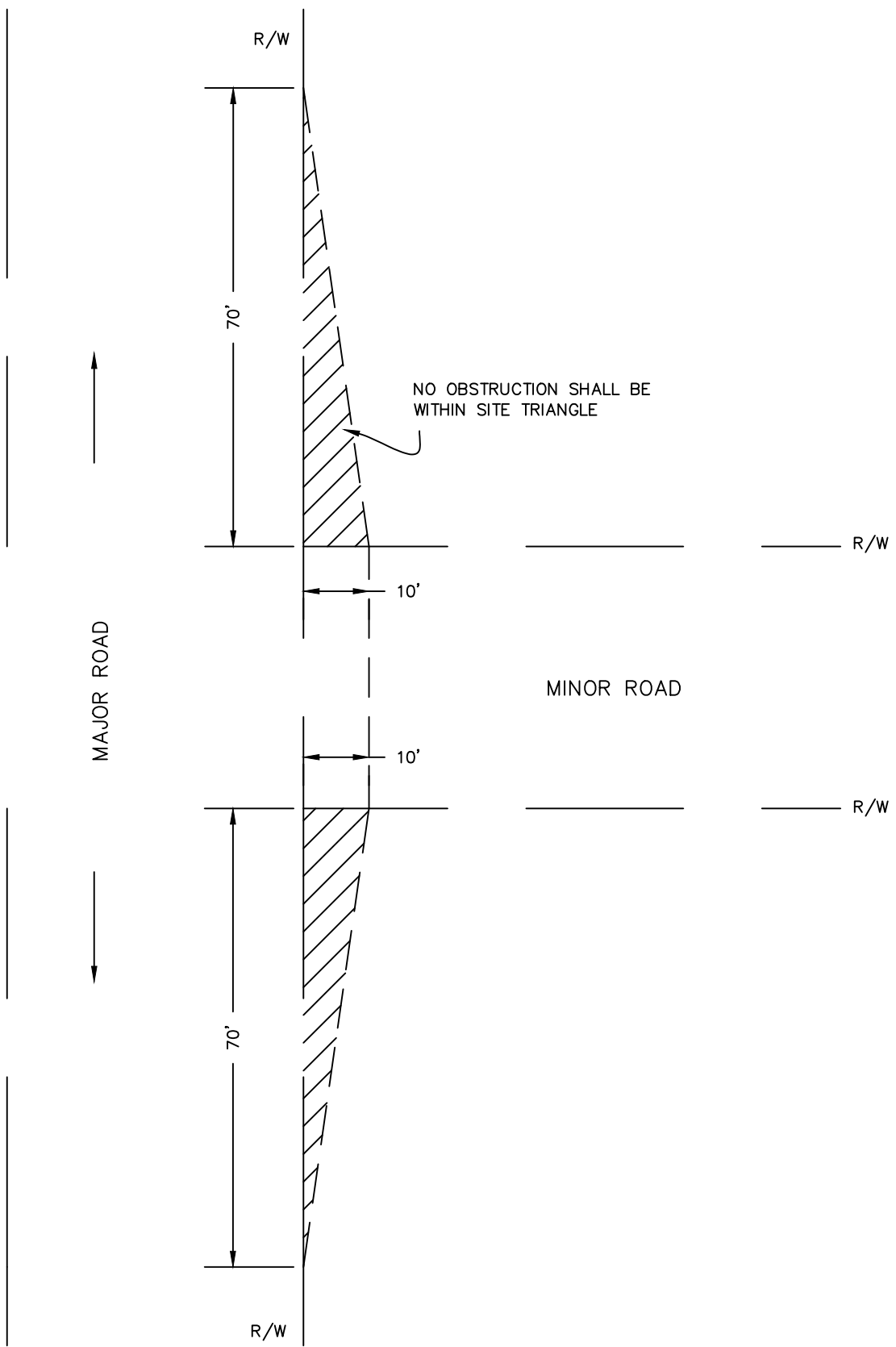

NOT TO SCALE



CITY OF HICKORY		SHEET 1 OF 1	
REQUIRED INTERSECTION SITE TRIANGLE		DATE: 2-1-07	STD. NO. 307

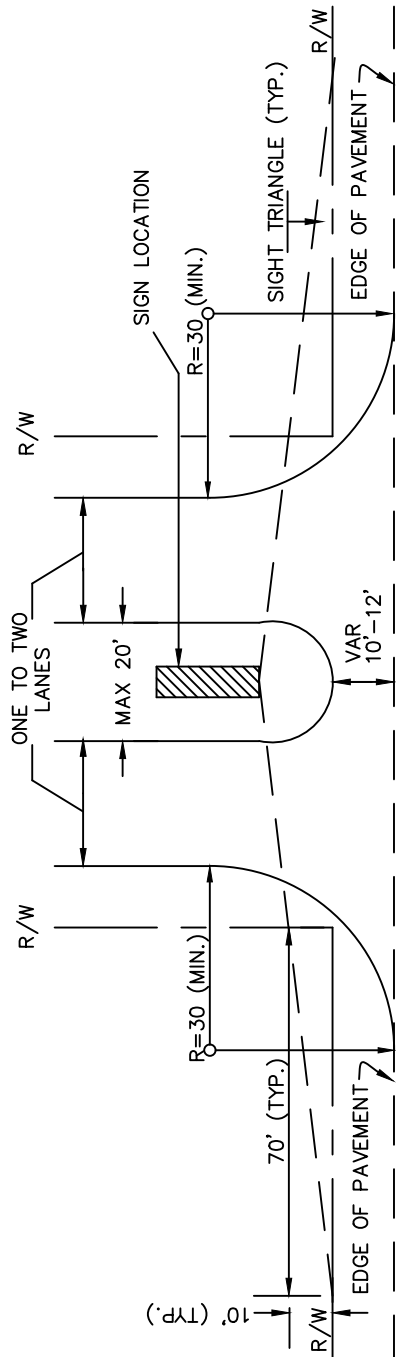

EXISTING ROAD

_____ R/W

NOT TO SCALE



CITY OF HICKORY

SIGHT TRIANGLE FOR DIVIDED ENTRANCE

SHEET 1 OF 1

DATE:
2-1-07

STD. NO.
308

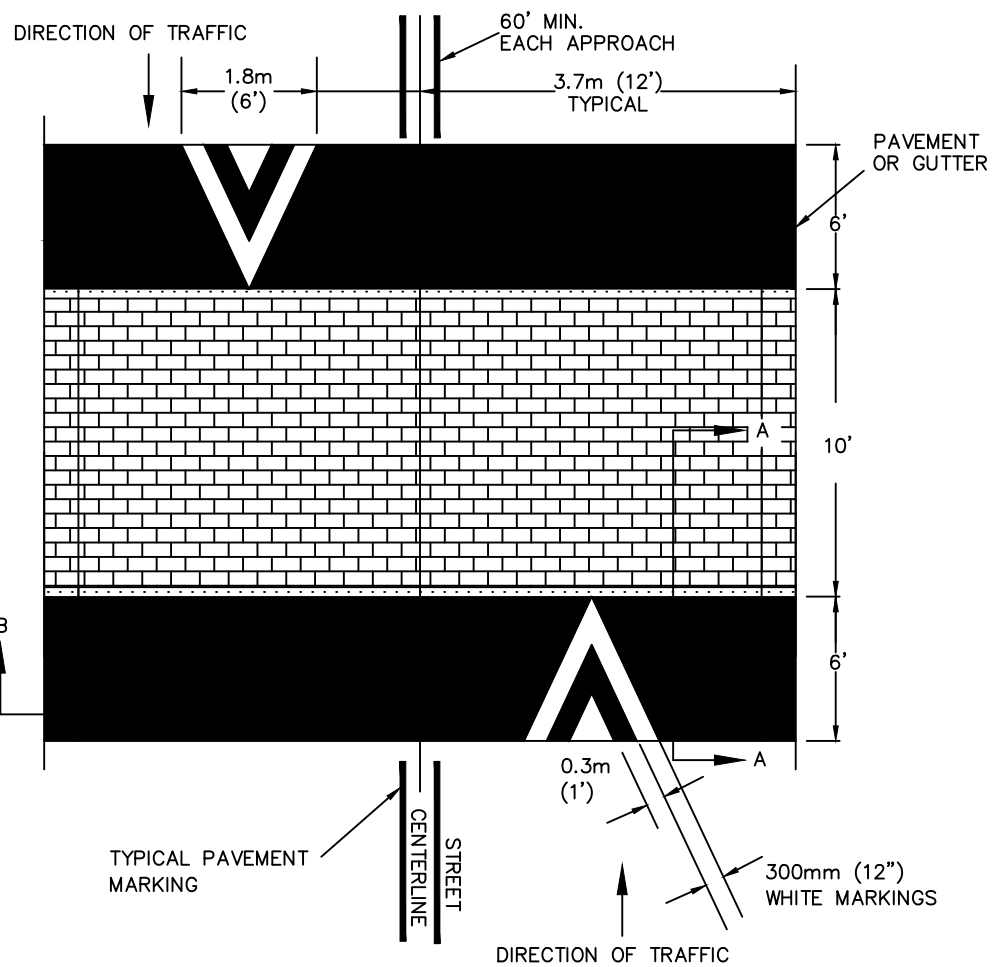

PLAN VIEW

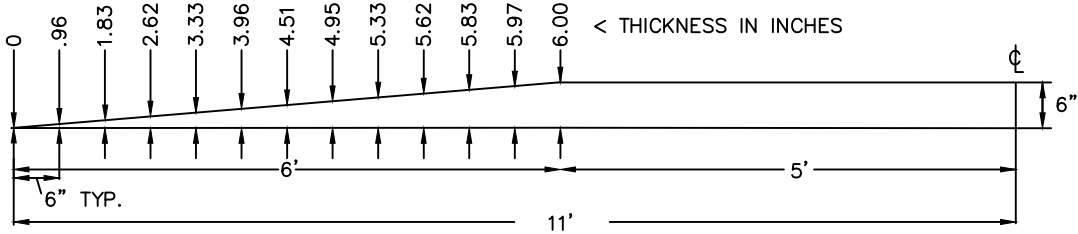

SECTION A-A

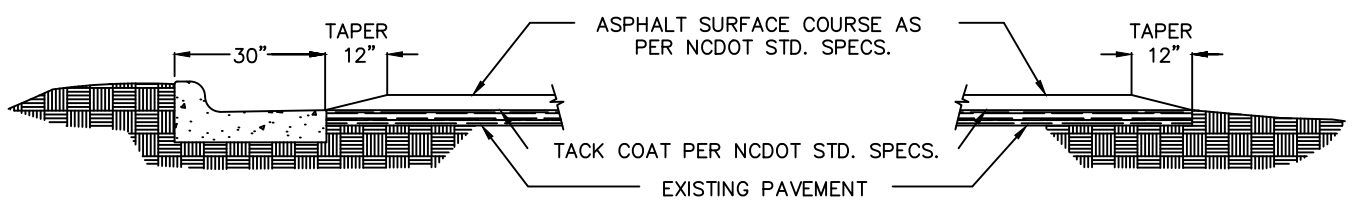

SECTION B-B

FOR STREETS WITH CURB & GUTTER

SECTION B-B

FOR STREETS WITHOUT CURB & GUTTER

NOT TO SCALE



CITY OF HICKORY

SPEED HUMP

DATE:
2-1-07

SHEET 1 OF 1

STD. NO.
309

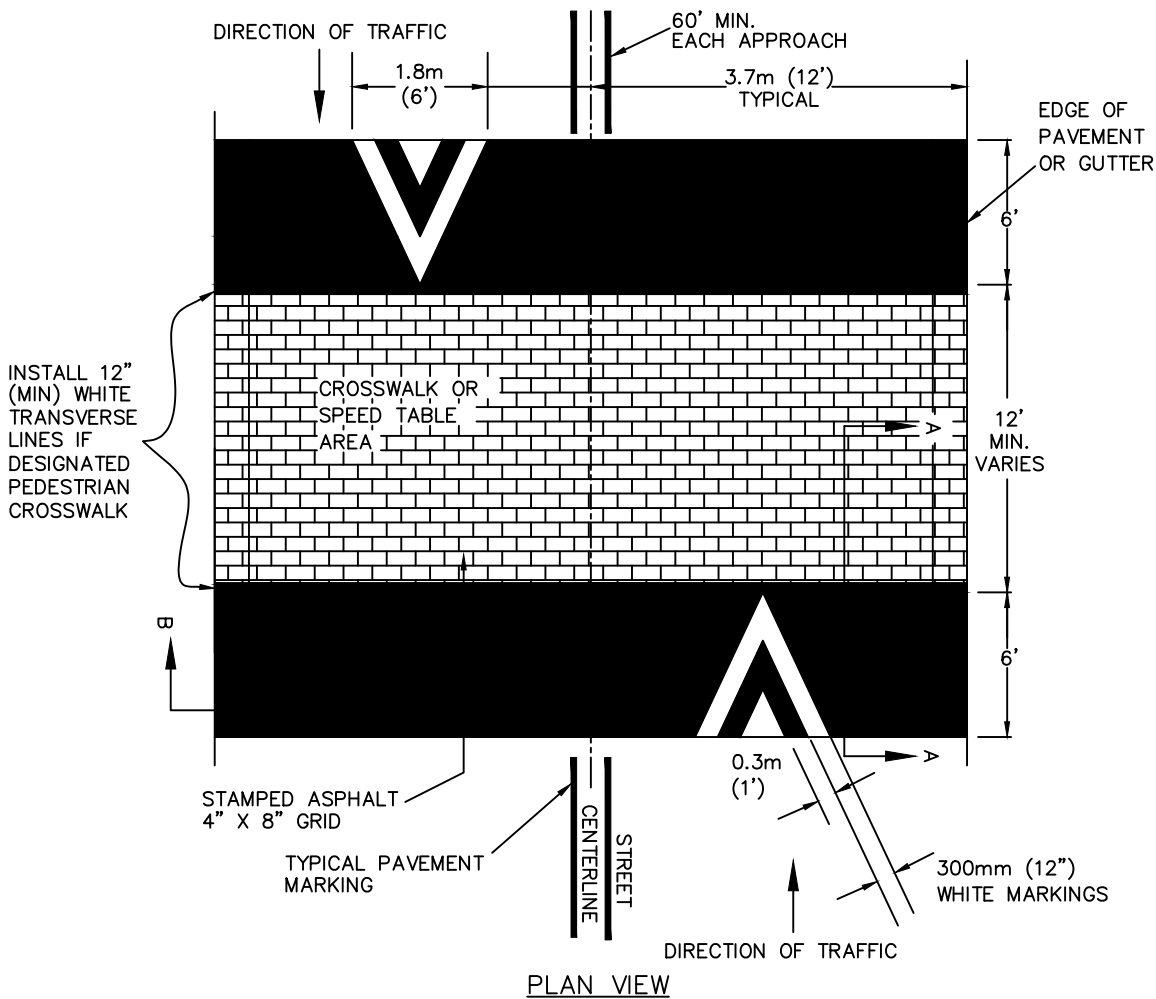

PLAN VIEW

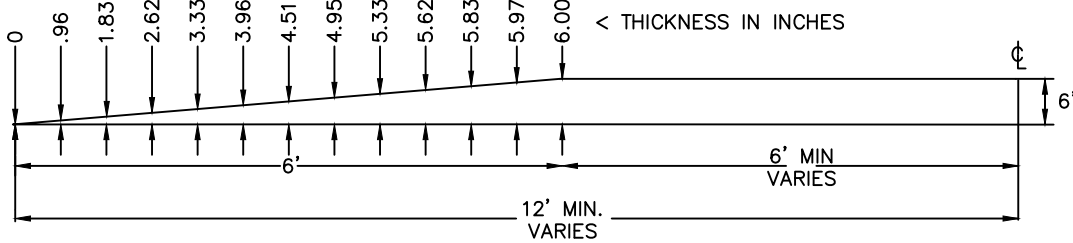

SECTION A-A

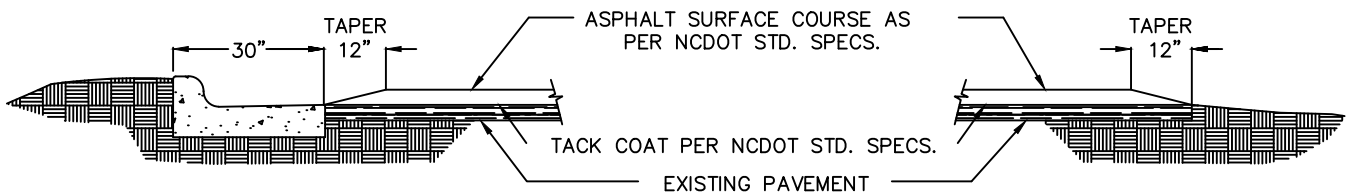

SECTION B-B

FOR STREETS WITH CURB & GUTTER

SECTION B-B

FOR STREETS WITHOUT CURB & GUTTER

NOT TO SCALE



CITY OF HICKORY

SPEED TABLE
OR PEDESTRIAN TABLE

SHEET 1 OF 1

DATE:
2-1-07

STD. NO.
310

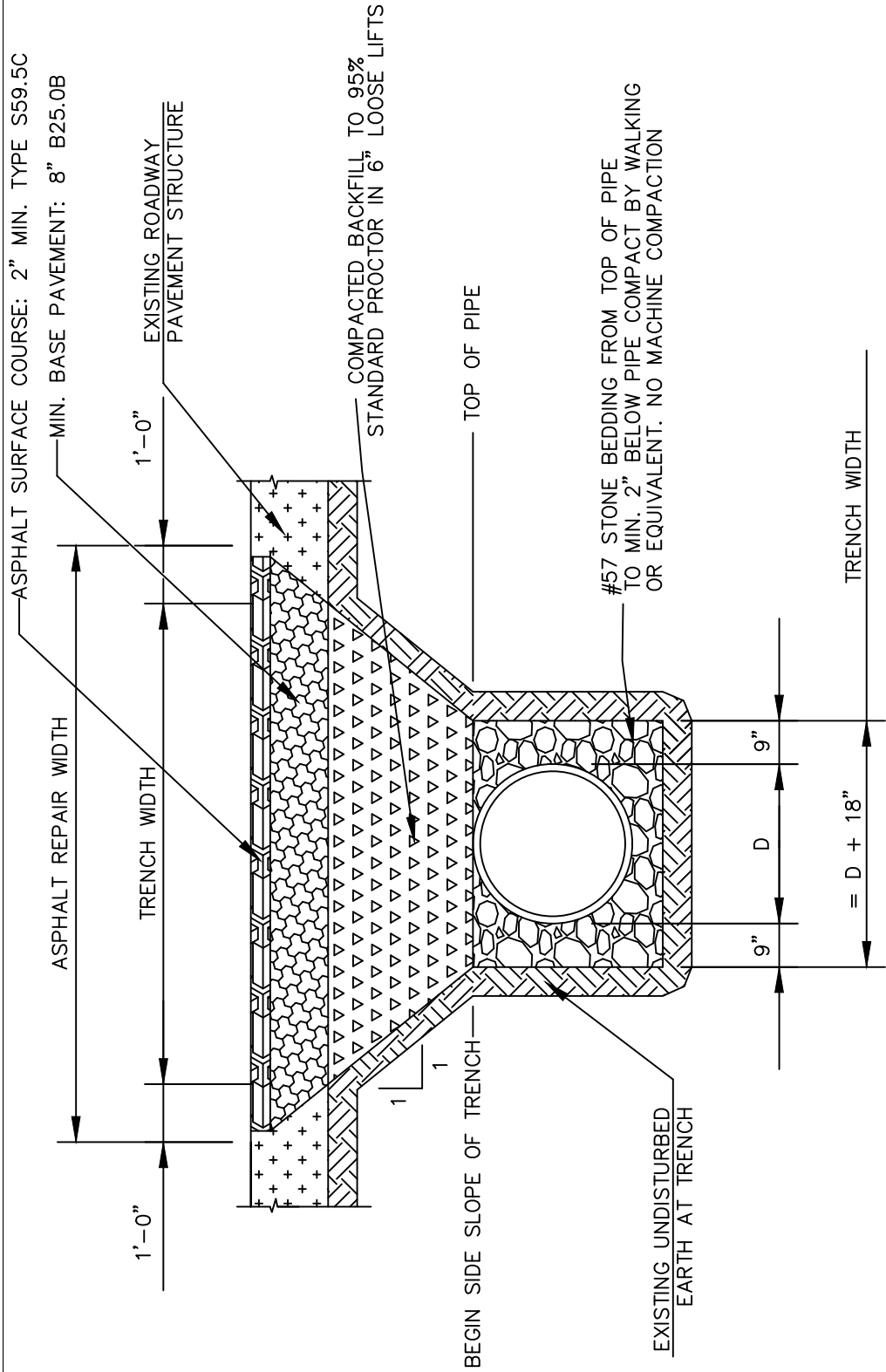

SECTION THROUGH TRENCH
REPAIR SECTION

REFER ALSO TO SECTION 301 GENERAL NOTES FOR STREETS FOR ADDITIONAL REQUIREMENTS

D = OUTSIDE PIPE DIAMETER

NOT TO SCALE



CITY OF HICKORY

TRENCH DETAIL FOR ROAD PATCH AND REPAIR

SHEET 1 OF 2

DATE:
9-8-22

STD. NO.
311

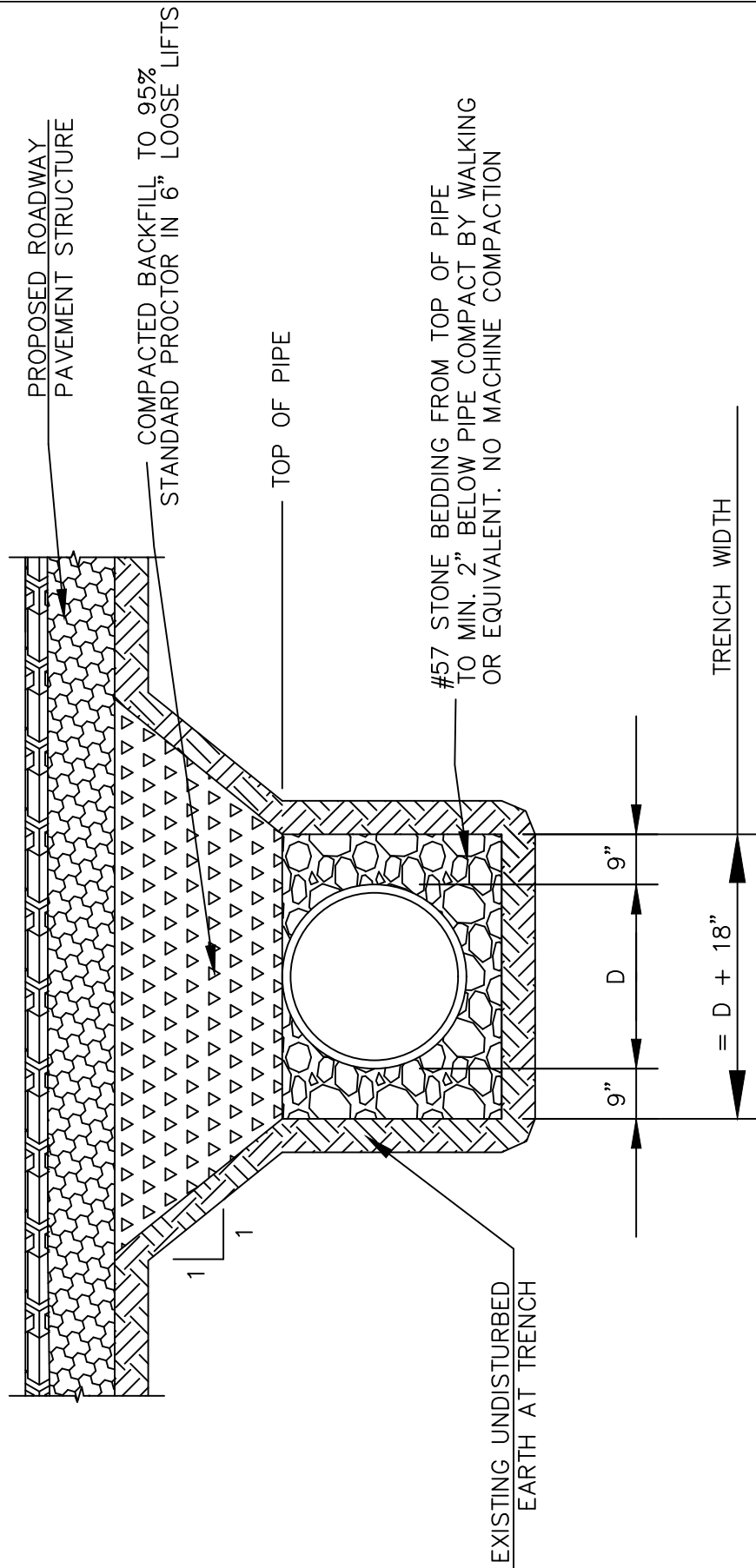

SECTION THROUGH TRENCH
NEW CONSTRUCTION

REFER ALSO TO SECTION 301 GENERAL NOTES FOR STREETS FOR ADDITIONAL REQUIREMENTS

NOT TO SCALE



CITY OF HICKORY

TRENCH DETAIL FOR
NEW UTILITY INSTALLATION

SHEET 2 OF 2

DATE:
2-1-07

STD. NO.
311

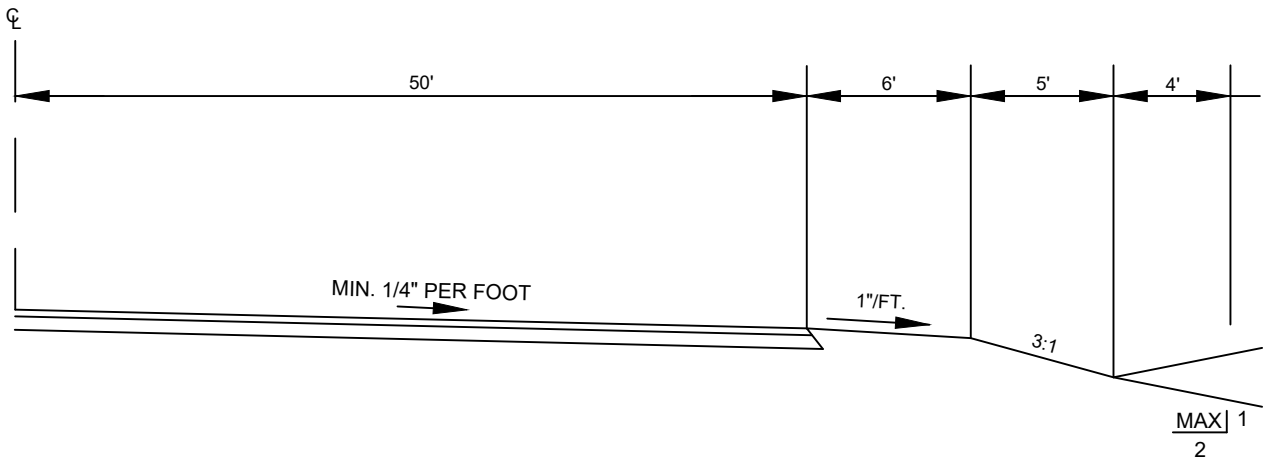
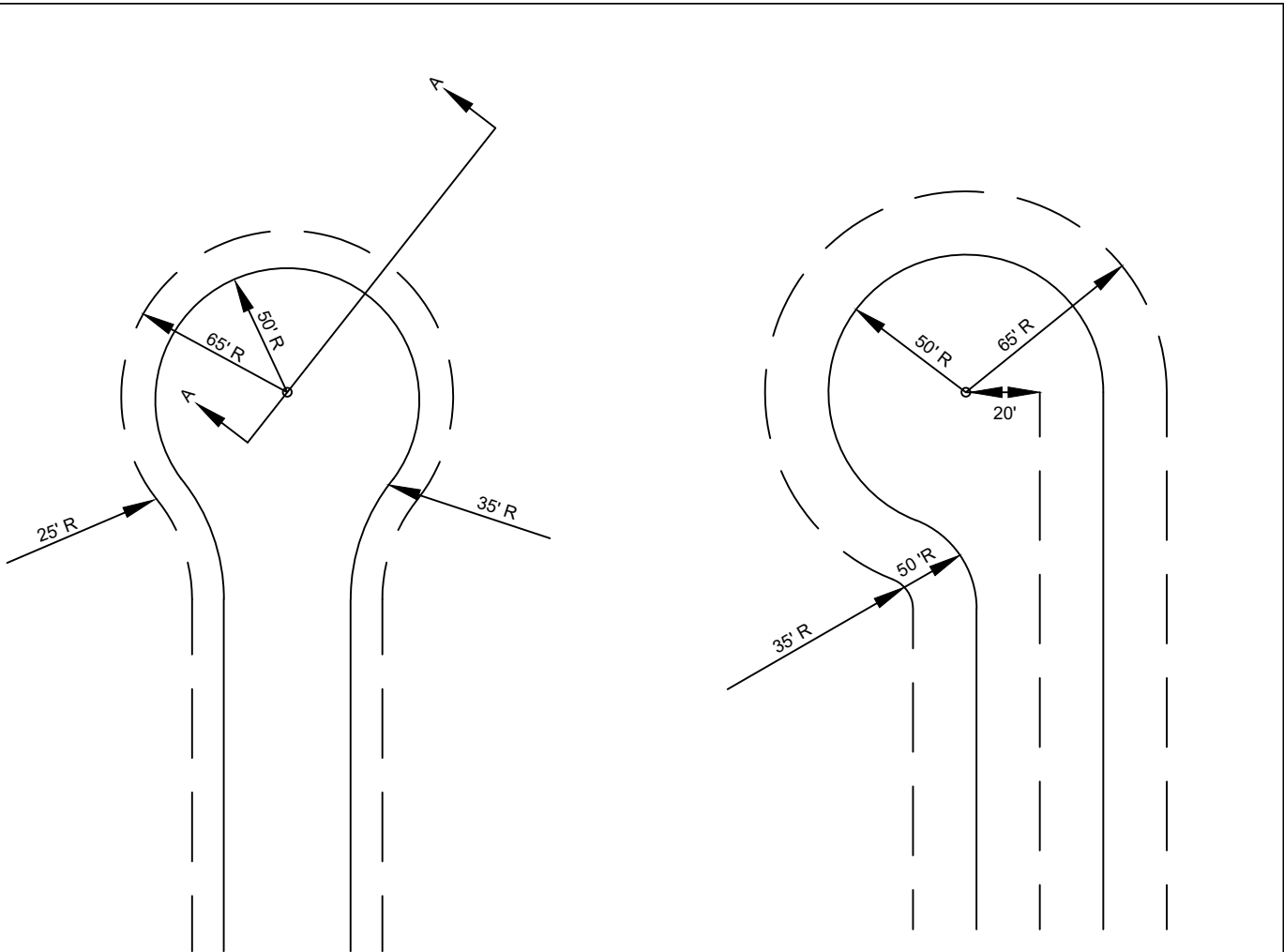

SECTION AA

NOT TO SCALE



CITY OF HICKORY
 SYMMETRICAL AND OFFSET CUL-DE-SAC
 NO CURB AND GUTTER

DATE: 01-03-24	SHEET 1 OF 2 STD. NO. 312
-------------------	---------------------------------

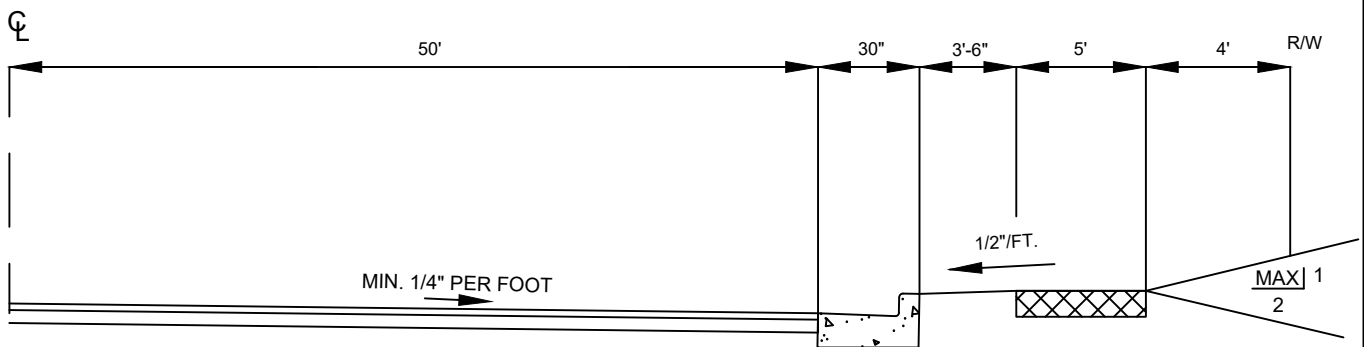
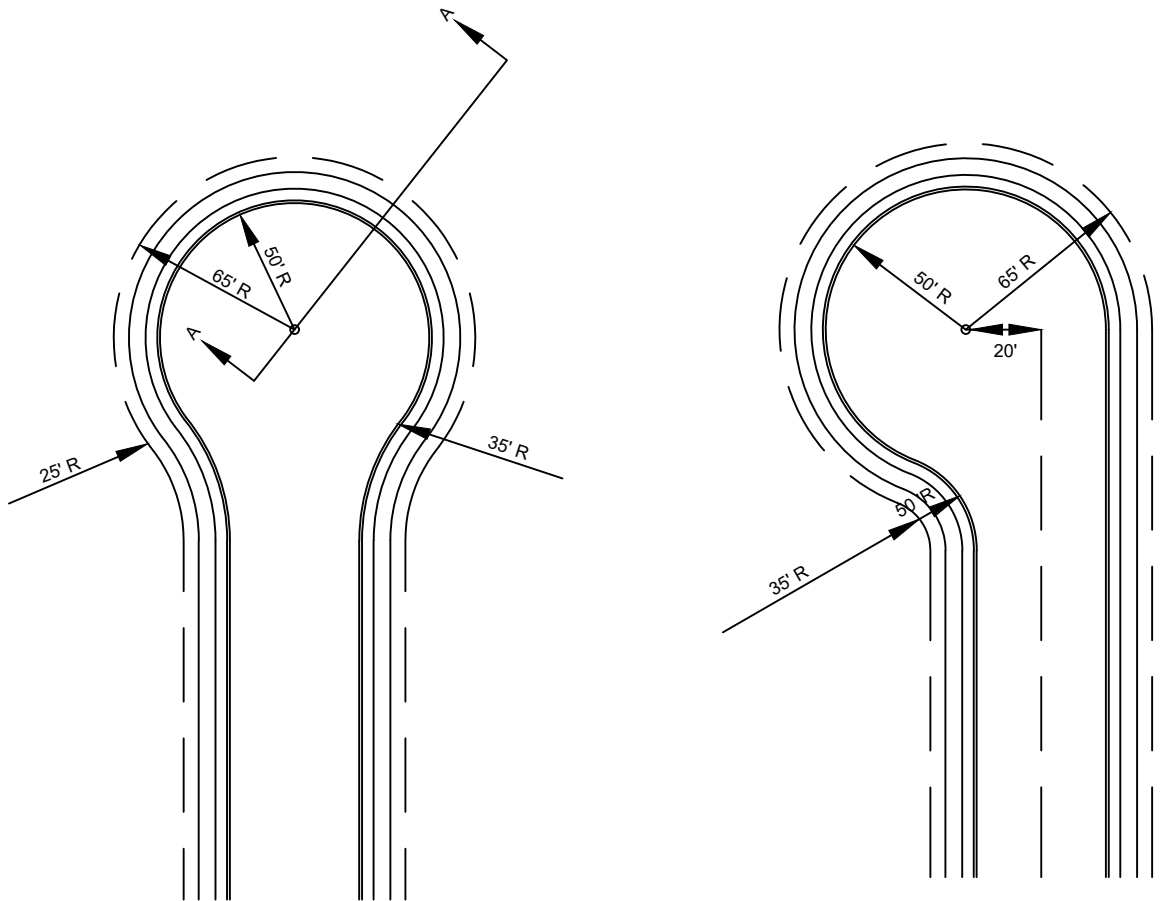

SECTION AA

* SLOPE AS PER PLANS

NOT TO SCALE



CITY OF HICKORY
 SYMMETRICAL AND OFFSET CUL-DE-SAC
 WITH CURB AND GUTTER & SIDEWALK

DATE:
 01-03-24

SHEET 2 OF 2
 STD. NO.
 312

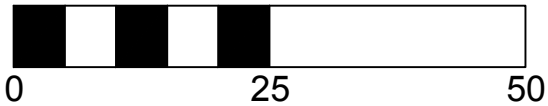
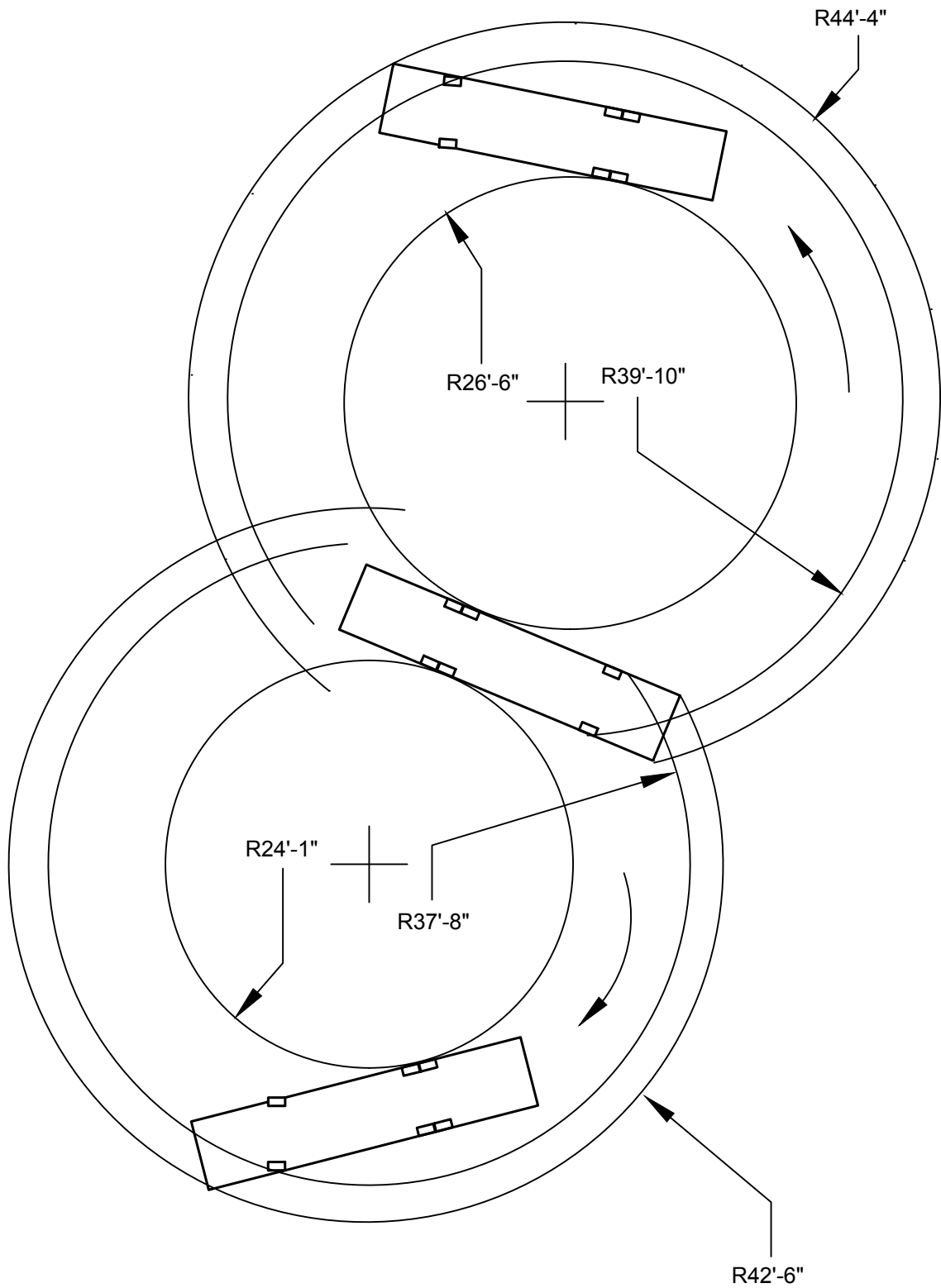

FIRE TRUCK RADII

LADDER 2 9-7-18

	CITY OF HICKORY	
	HEAVY EQUIPMENT TURNING RADII	SHEET 1 OF 2
	DATE: 10-24-18	STD. NO. 313

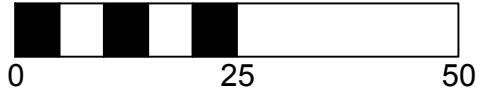
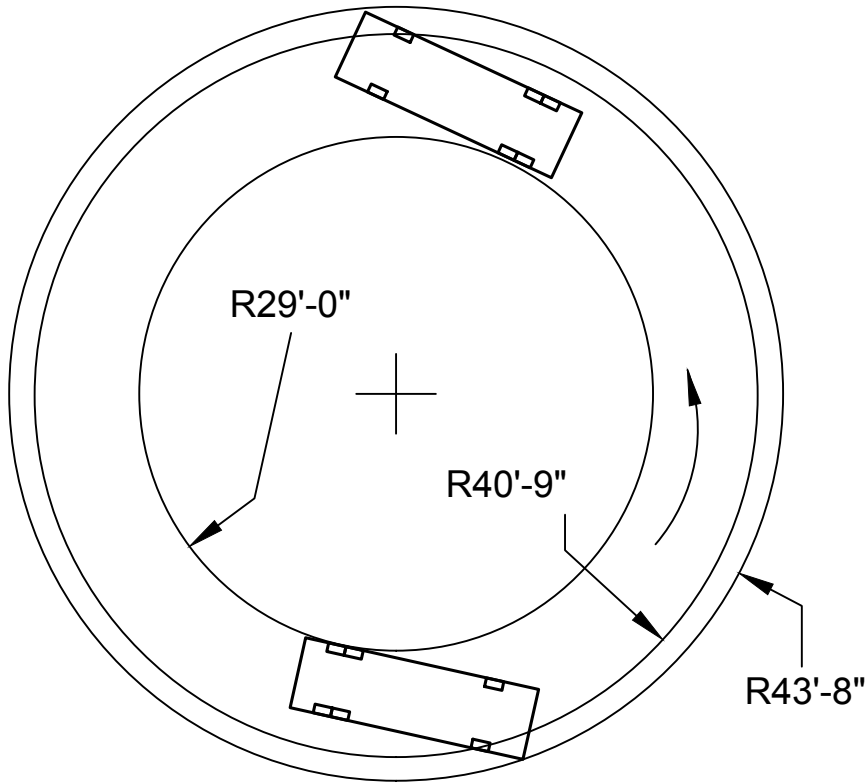
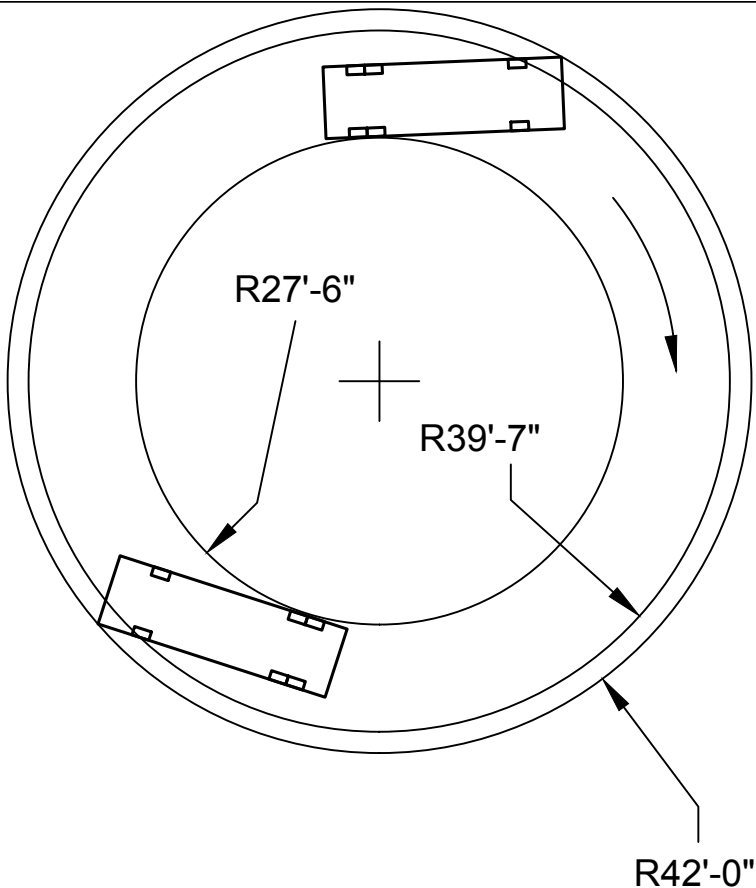

GARBAGE TRUCK TURNING RADII

AUTOCAR - FRONT LOADER 2 9-7-18



CITY OF HICKORY

HEAVY EQUIPMENT TURNING RADII

SHEET 2 OF 2

DATE:
10-24-18

STD. NO.
313

Survey Requirements

For

City of Hickory

Street Right-of-way

Acquisition Projects

- All survey work shall conform to accepted survey practices as defined by North Carolina General Statute and by North Carolina Board of Examiners for Engineers and Surveyors rules and policies.
- The project shall be tied to the current North Carolina grid projection. Traditional grid ties or GPS grid ties are acceptable.
- All locations shall be traditional field locations.
- All property corners, that are existing, for all properties affected by the project shall be located and shown on all drawings.
- All property corners shall be indicated by size and type.
- All structures, closest to the right-of-way in question, shall be located and shown on all drawings.
- All utilities shall be located including, but not limited to, telephone, power, guy wires, fiber optic, water valves, water meters, sanitary sewer manholes, sanitary sewer clean outs, fire hydrants, etc.
- All storm water features, on both sides of the street, shall be located, including, but not limited to, size, type and depth of pipe and size, type and depth of box.
- All water features shall be located.
- Locations shall be from the centerline of the street to the side the right-of-way acquisition will be on.
- All new right-of-way markers shall be set before final easements are turned in to the City of Hickory for right-of-way acquisition.



CITY OF HICKORY

STREET RIGHT-OF-WAY ACQUISITION
SURVEY REQUIREMENTS

SHEET 1 OF 2

DATE:
04-18-19

STD. NO.
314

Easement Map Requirements

For

City of Hickory

Street Right-of-Way

Acquisition Projects

- All easement maps shall conform to North Carolina Board of Examiners for Engineers and Surveyors policy BP-1709-1.
- All easement maps shall be tied to the current North Carolina grid projection. Traditional grid ties or GPS grid ties are acceptable.
- All easement maps shall be on 8 ½" x 14" sheets to be recorded with the written easement.
- All properties affected by the right-of-way project shall have separate easement maps.
- All easement maps shall show the new right-of-way, a slope easement, if necessary, and a temporary construction easement 10' (feet) wide, if necessary, that shall be parallel to the new right-of-way or the slope easement.
- All easement maps shall show the areas for proposed right-of-way, slope easement and temporary construction easement, as necessary.
- All easement maps shall show the distance from the new right-of-way line to the nearest existing structure, i.e. houses, businesses, etc.
- All property corners shall be labeled with size and type.
- All new right-of-way monuments shall be labeled with size and type.
- All new right-of-way markers shall be set before final easements are turned in to the City of Hickory for right-of-way acquisition.
- New right-of-way monuments shall be 1/2" or 5/8" rods or re-bars.



CITY OF HICKORY

STREET RIGHT-OF-WAY ACQUISITION
SURVEY REQUIREMENTS

SHEET 2 OF 2

DATE:
04-18-19

STD. NO.
314

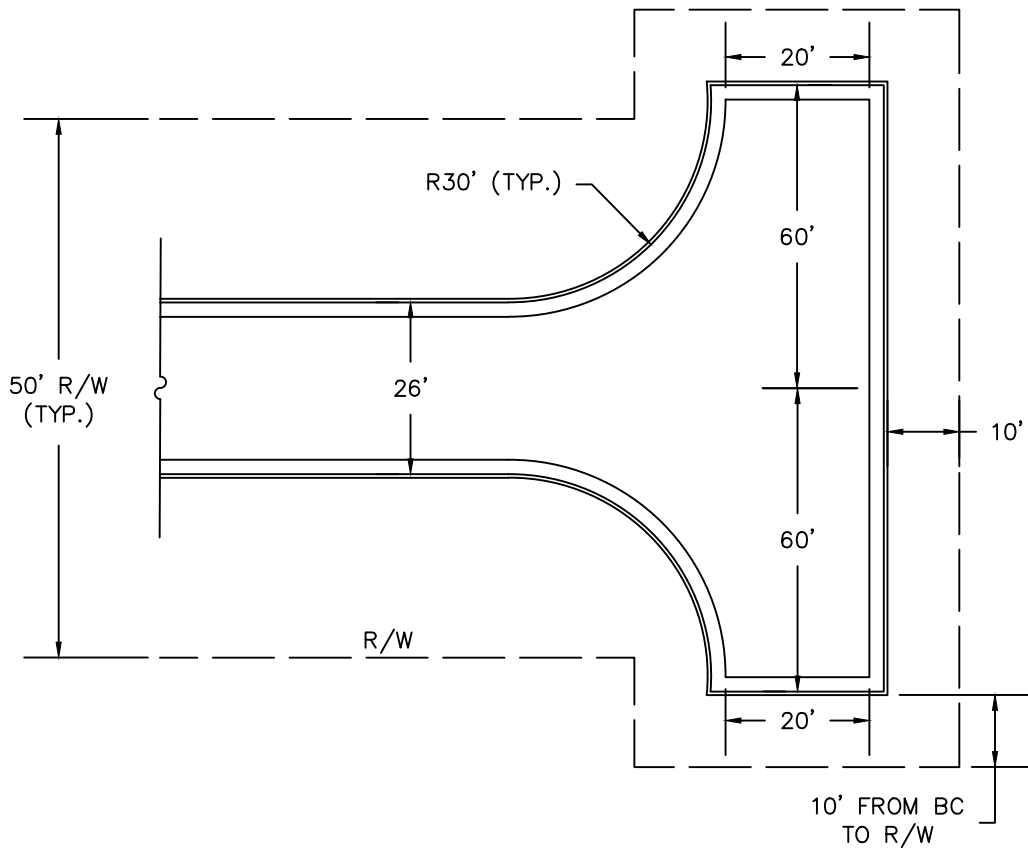
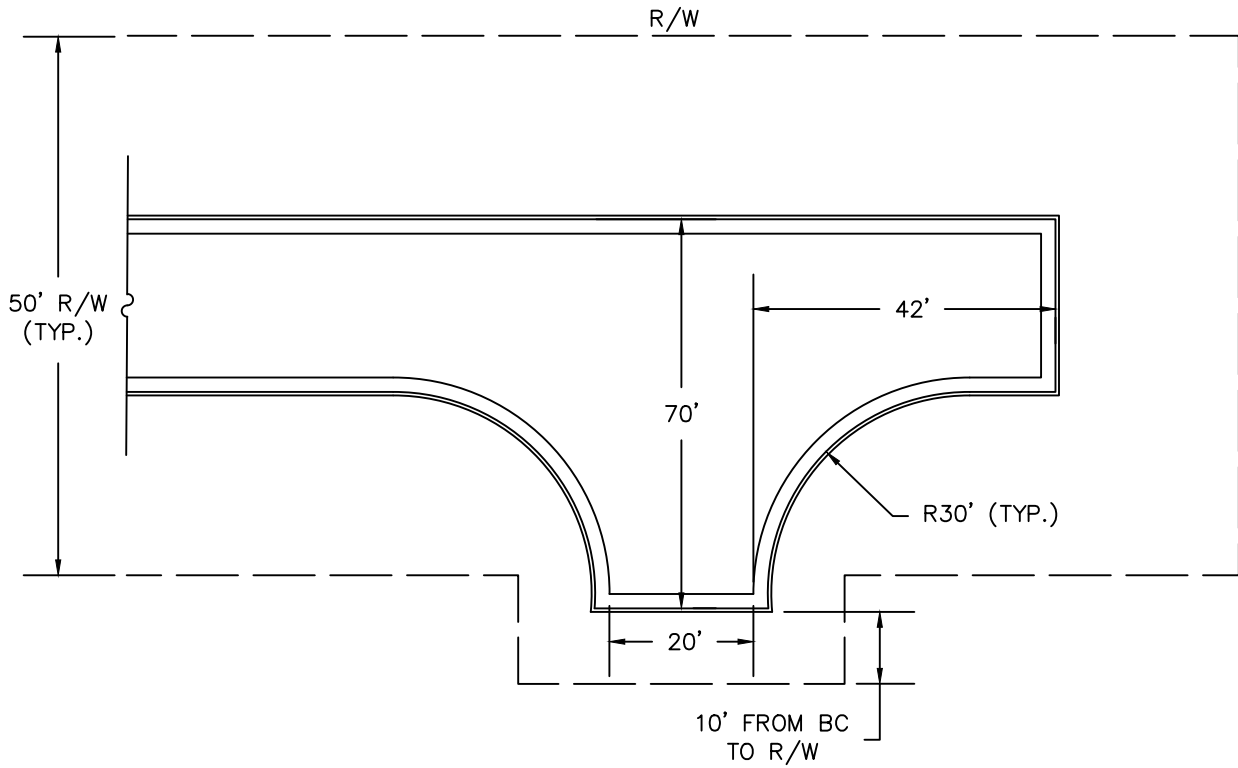

NOT TO SCALE



CITY OF HICKORY

TURN AROUND FOR
DEAD END STREET

SHEET 1 OF 1

DATE:
01-03-24

STD. NO.
315

Engineering Department
Manual Of
Practice



Life. Well Crafted.

400 Curb & Gutter, Sidewalks &
Driveways

DIVISION 400 CURB & GUTTER, SIDEWALKS, & DRIVEWAYS

A. GENERAL NOTES

1. Sidewalks shall be constructed of not less than 3000 P.S.I. concrete and shall be four (4) inches thick, constructed on an adequately graded and compacted base, except where a sidewalk crosses a driveway it shall be six (6) inches thick. Subgrade shall be compacted to 95% of the maximum density as measured by Standard. The surface of the sidewalk shall be steel trowel and light broom finished and cured with an acceptable curing compound. Tooled joints shall be provided at intervals of not less than five (5) feet and expansion joints at intervals of not more than thirty (30) feet. The sidewalk shall have a lateral slope of one-quarter (1/4) inch per foot from outside edge of sidewalk to the top of curb.

2. Accessible ramps are required where sidewalks intersect curbing.

3. No driveway shall be installed within thirty (30) feet of an intersection without express written approval by City Traffic Engineer and/or City Engineer.

REFERENCES

1. North Carolina Department of Transportation, Standard Specifications for Roads and Structures, Latest Edition

2. North Carolina Department of Transportation, Roadway Design Manual, Latest Edition

3. American Association of State Highway and Transportation Officials, Latest Edition, A Policy on Geometric Design of Highways and Streets



CITY OF HICKORY

GENERAL NOTES FOR CURB & GUTTER,
SIDEWALKS, & DRIVEWAYS

SHEET 1 OF 1

DATE:
12-06-21

STD. NO.
401

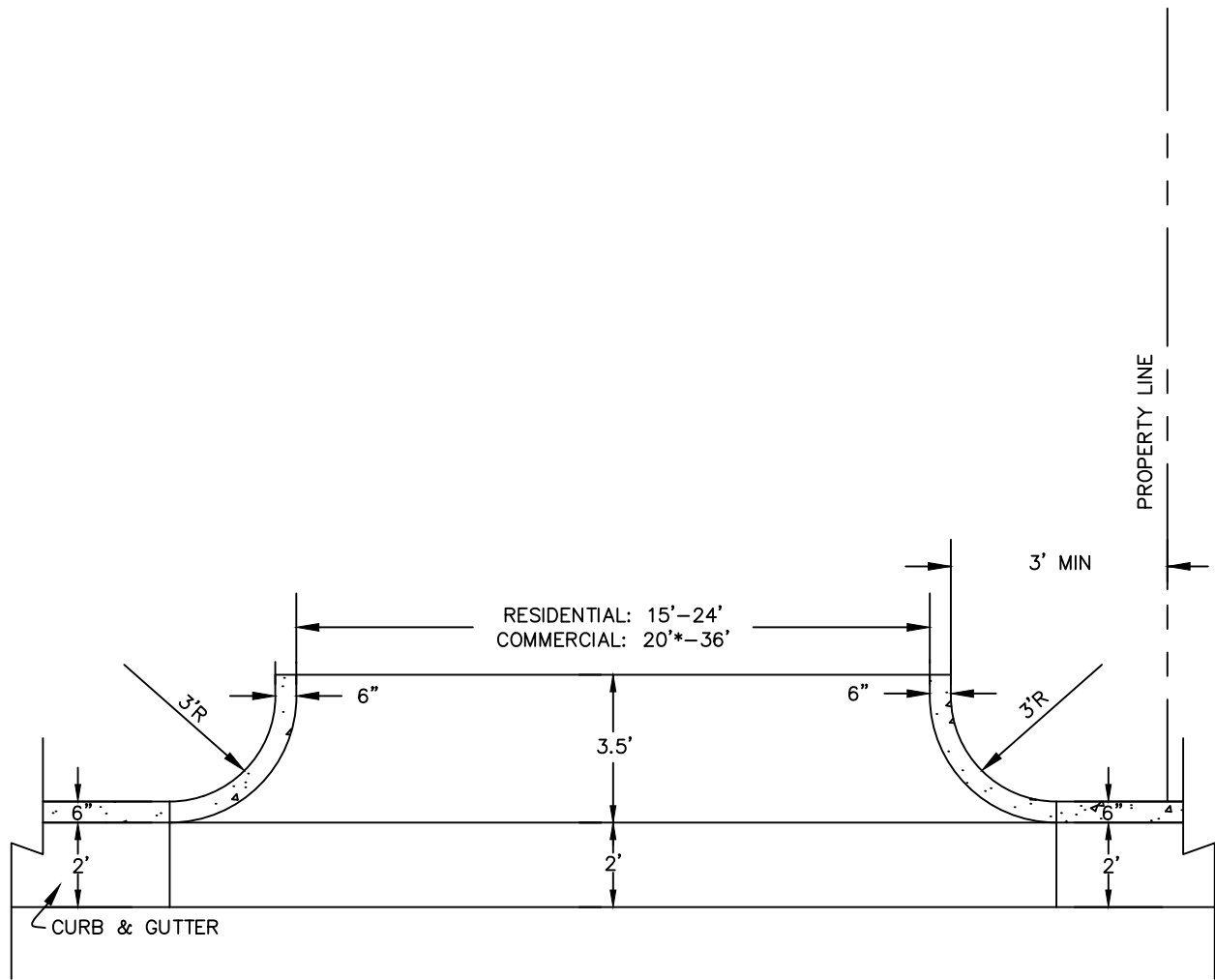

* COMMERCIAL: TWO-WAY MINIMUM 20'

NOTE:
 ALL DRIVEWAY LOCATIONS, GRADES, AND CUTS SHALL BE AT A MINIMUM IN ACCORDANCE WITH THE LATEST EDITION OF THE "POLICY ON STREET AND DRIVEWAY ACCESS TO NORTH CAROLINA HIGHWAYS," PUBLISHED BY THE NORTH CAROLINA DEPARTMENT OF TRANSPORTATION TRAFFIC ENGINEERING BRANCH.

NOT TO SCALE



CITY OF HICKORY

TYPICAL DRIVEWAY CUT

SHEET 1 OF 1

DATE:
2-1-07

STD. NO.
402

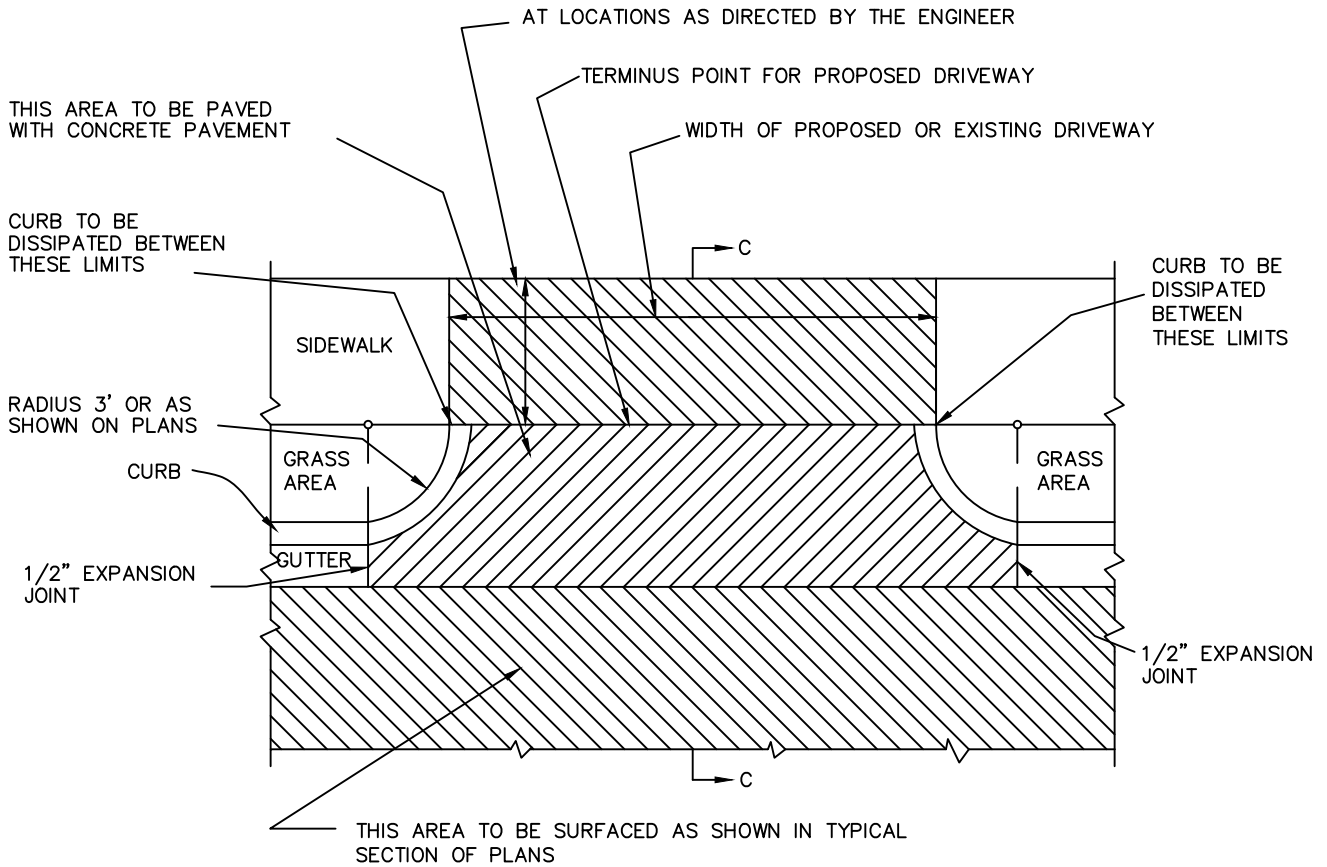

PART PLAN PAVED DRIVEWAY TURNOUT

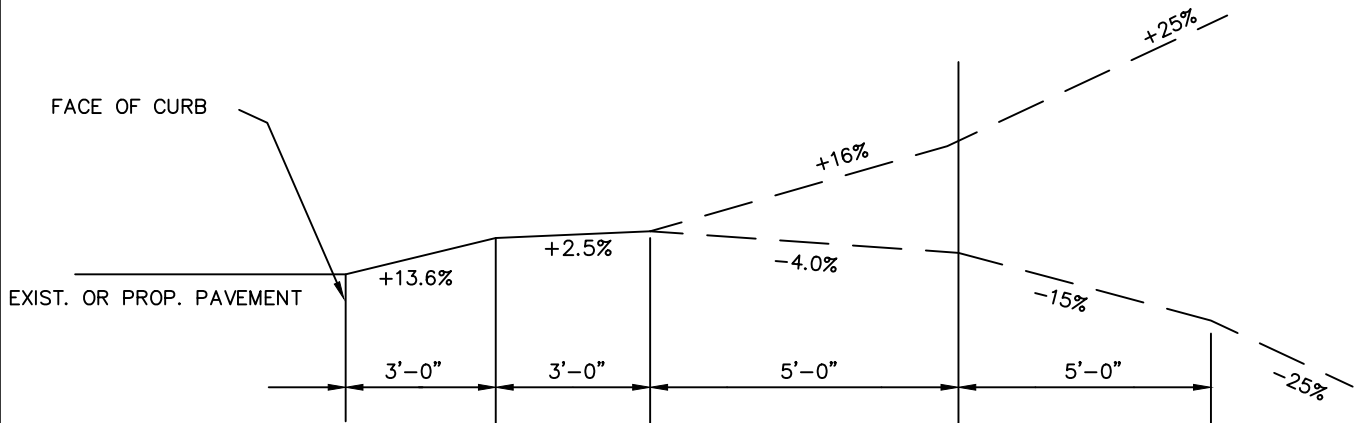

DRIVEWAY TURNOUT GRADES

NOT TO SCALE



CITY OF HICKORY

DRIVEWAY TURNOUT RADIUS TYPE

SHEET 1 OF 2

DATE:
2-1-07

STD. NO.
404

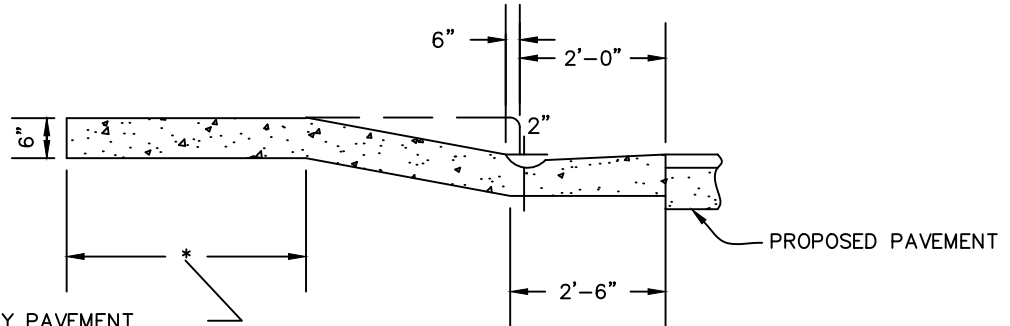

THIS PORTION OF DRIVEWAY PAVEMENT TO BE BUILT ONLY AT LOCATIONS AS DIRECTED BY THE ENGINEER

SECTION-CC

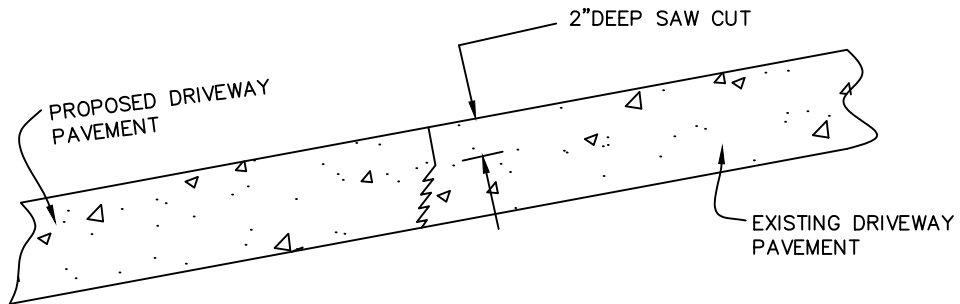

METHOD OF TIE IN

WHEN EXISTING DRIVEWAY PAVEMENT IS CONCRETE, A SAW CUT 2" DEEP SHALL BE REQUIRED AT THE POINT OF TIE IN WITH EXISTING DRIVEWAY GRADE. SAW JOINT TO BE PERPENDICULAR TO EDGE OF EXISTING DRIVEWAY PAVEMENT.

NOT TO SCALE



CITY OF HICKORY

DRIVEWAY TURNOUT RADIUS TYPE

SHEET 2 OF 2

DATE:
2-1-07

STD. NO.
402

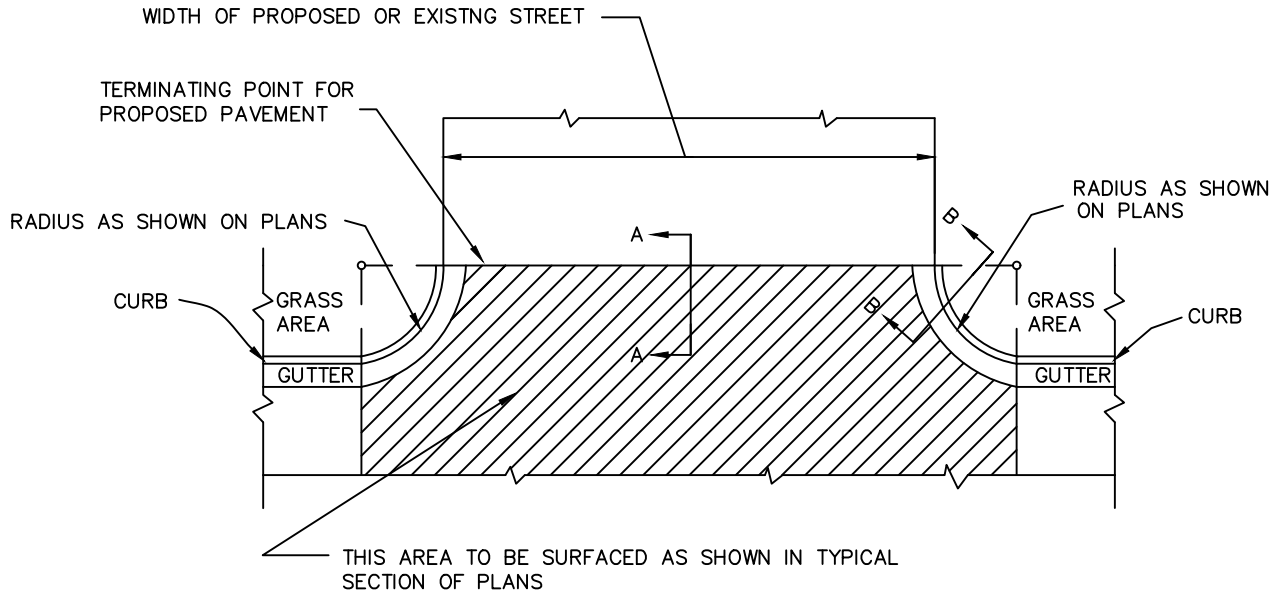

PART PLAN PAVED DRIVEWAY TURNOUT

TO BE USED ON PROPOSED AND EXISTING STREET INTERSECTIONS
OR MAJOR TYPE COMMERCIAL ENTRANCES

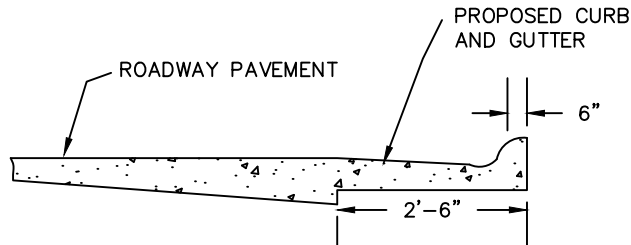

SECTION-BB

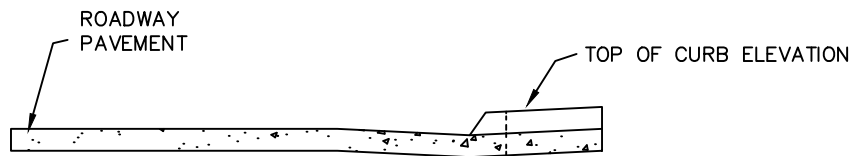

SECTION-AA

NOT TO SCALE



CITY OF HICKORY

DESIGN STANDARDS FOR
STREET TURNOUTS

SHEET 1 OF 1

DATE:
2-1-07

STD. NO.
405

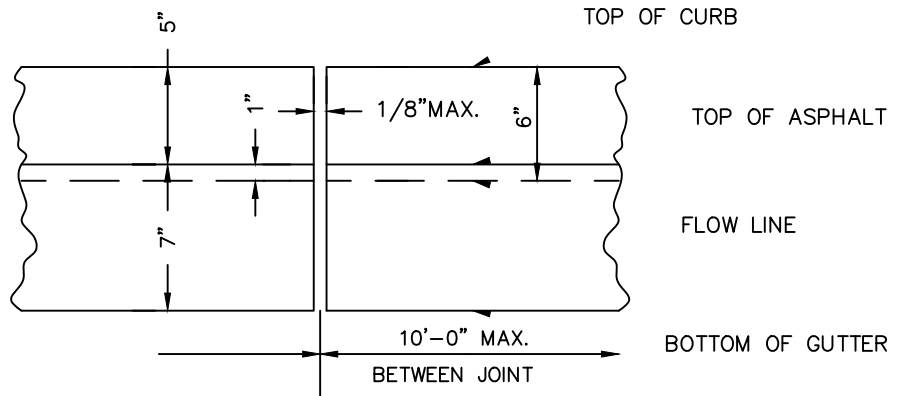
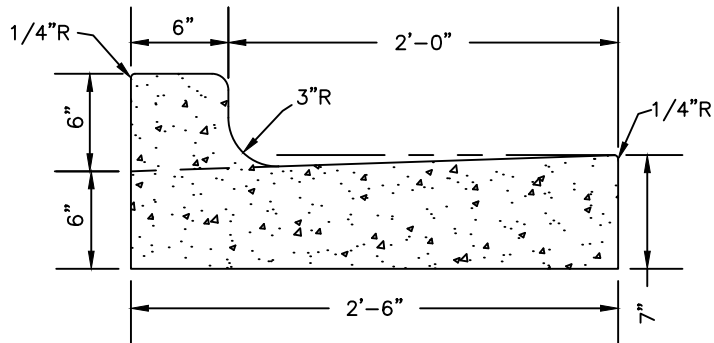

NOTES:

1. CONCRETE SHALL BE CLASS B, 3000 PSI COMPRESSIVE STRENGTH IN 28 DAYS.
2. CONTRACTION JOINTS SHALL BE SPACED AT 10 FOOT INTERVALS. A 15' SPACING MAY BE USED WHEN A MACHINE IS USED. JOINT SPACING MAY BE ALTERED BY THE ENGINEER TO PREVENT UNCONTROLLED CRACKING.
3. CONTRACTION JOINTS MAY BE INSTALLED BY THE USE OF TEMPLATES OR FORMED BY OTHER APPROVED METHODS.
WHERE SUCH JOINTS ARE NOT FORMED BY TEMPLATES, A MINIMUM SCORE DEPTH OF 1 1/2" SHALL BE OBTAINED.
4. ALL EXPANSION JOINTS SHALL BE SPACED AT 90 FOOT MAXIMUM INTERVALS, AND ADJACENT TO ALL RIGID OBJECTS.
5. CURB SHALL BE DEPRESSED AT INTERSECTIONS TO PROVIDE FOR FUTURE ACCESSIBLE RAMPS.
6. TOP OF 6" SUBGRADE BENEATH THE CURB AND GUTTER SHALL BE COMPACTED TO 100% STANDARD PROCTOR DENSITY.
7. ALL GUTTERS SHALL BE SLOPED AS NECESSARY TO PREVENT PONDING.

NOT TO SCALE



CITY OF HICKORY

STANDARD 30" CURB AND GUTTER

SHEET 1 OF 1

DATE:
2-1-07

STD. NO.
406

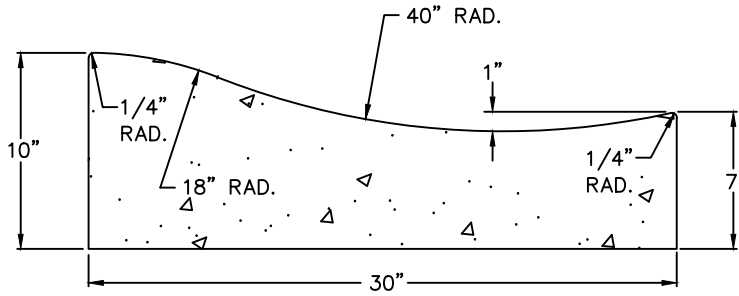

VALLEY GUTTER CROSS-SECTION

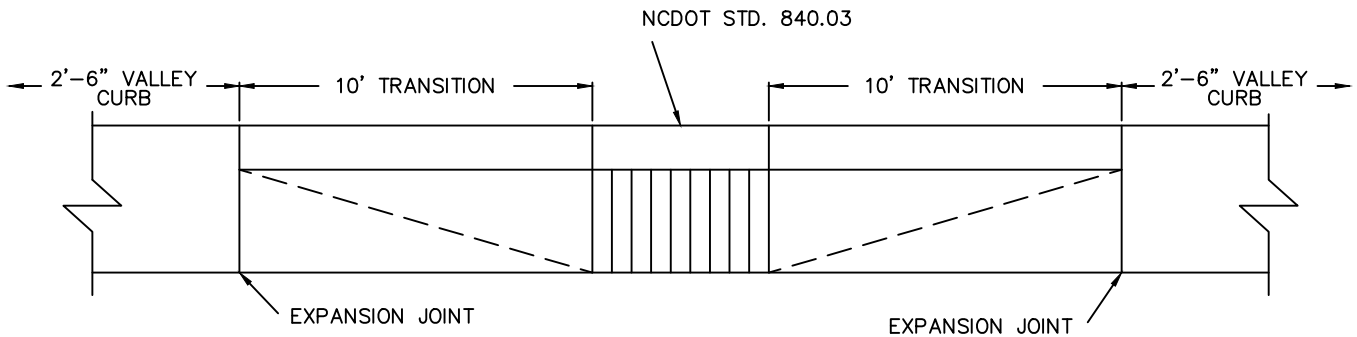

CATCH BASIN TRANSITION
PLAN VIEW

NOTES:

1. CONCRETE SHALL BE CLASS B, 3000 PSI COMPRESSIVE STRENGTH IN 28 DAYS.
2. CONTRACTION JOINTS SHALL BE SPACED AT 10 FOOT INTERVALS. A 15' SPACING MAY BE USED WHEN A MACHINE IS USED. JOINT SPACING MAY BE ALTERED BY THE ENGINEER TO PREVENT UNCONTROLLED CRACKING.
3. CONTRACTION JOINTS MAY BE INSTALLED BY THE USE OF TEMPLATES OR FORMED BY OTHER APPROVED METHODS. WHERE SUCH JOINTS ARE NOT FORMED BY TEMPLATES, A MINIMUM SCORE DEPTH OF 1 1/2" SHALL BE OBTAINED.
4. ALL EXPANSION JOINTS SHALL BE SPACED AT 90 FOOT MAXIMUM INTERVALS, AND ADJACENT TO ALL RIGID OBJECTS.
5. CURB SHALL BE DEPRESSED AT INTERSECTIONS TO PROVIDE FOR FUTURE ACCESSIBLE RAMPS.
6. CURB SHALL BE PLACED ON 6" STONE BASE
7. TOP OF 6" SUBGRADE BENEATH THE STONE BASE SHALL BE COMPACTED TO 100% STANDARD PROCTOR DENSITY
8. ALL GUTTERS SHALL BE SLOPED AS NECESSARY TO PREVENT PONDING.

NOT TO SCALE



CITY OF HICKORY

30" VALLEY GUTTER

SHEET 1 OF 1

DATE:
4-25-23

STD. NO.
407

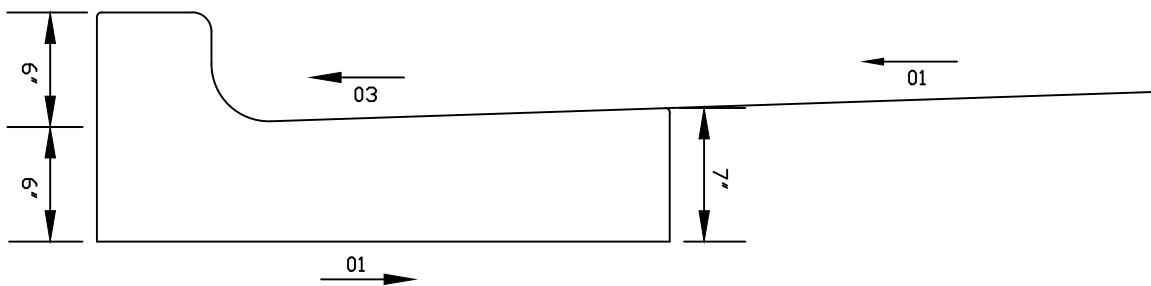
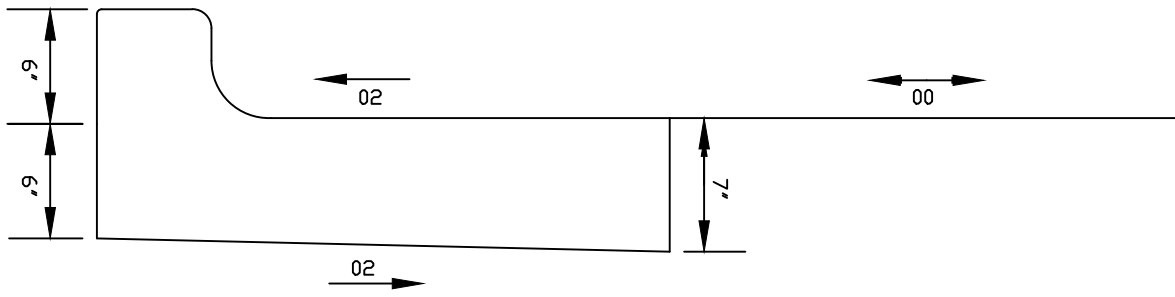
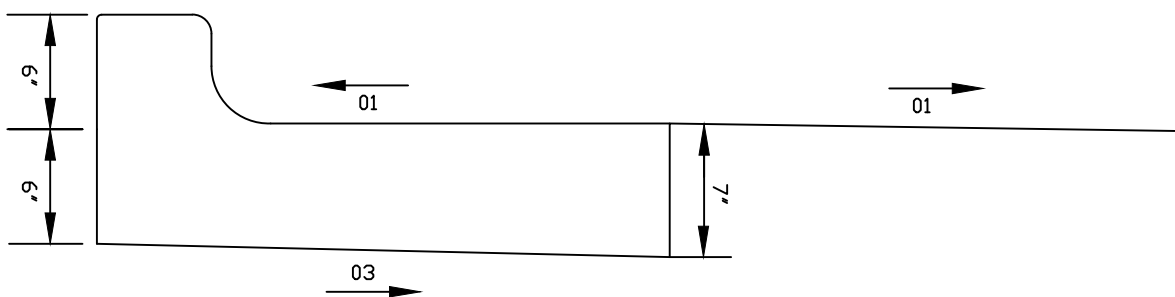
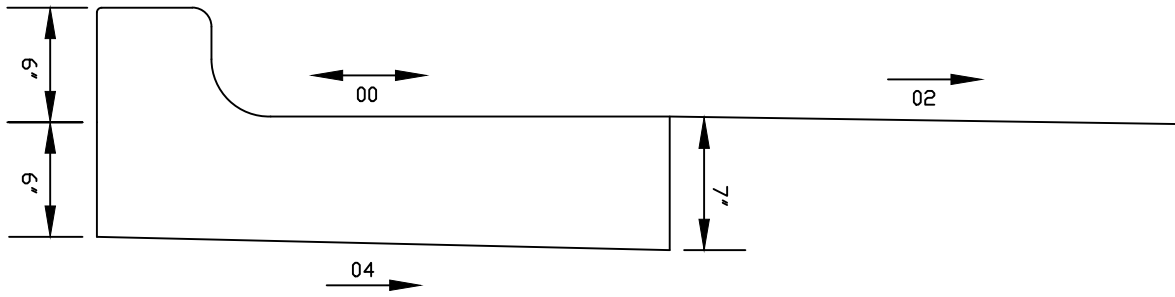
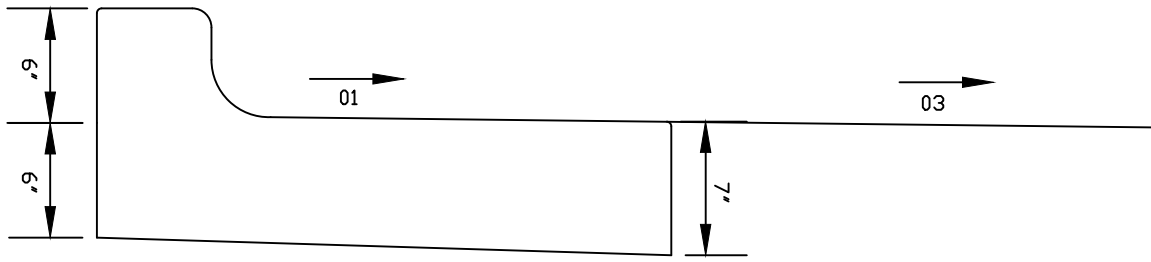

NOT TO SCALE



CITY OF HICKORY

CURB AND GUTTER FOR VARIABLE
SUPER ELEVATIONS RATES

SHEET 1 OF 2

DATE:
2-1-07

STD. NO.
408

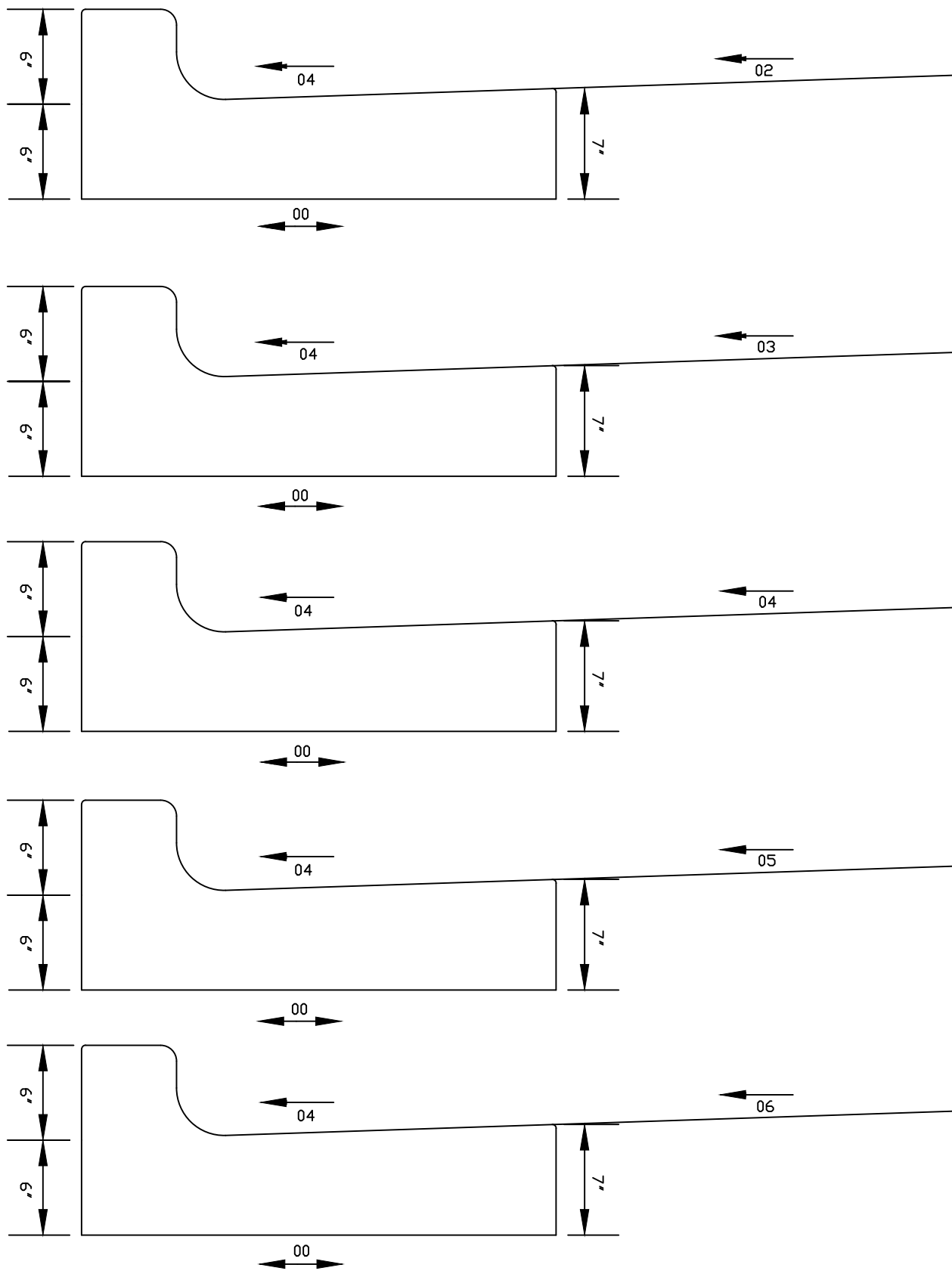

NOT TO SCALE



CITY OF HICKORY		SHEET 2 OF 2	
CURB AND GUTTER FOR VARIABLE SUPER ELEVATIONS RATES		DATE: 2-1-07	STD. NO. 408

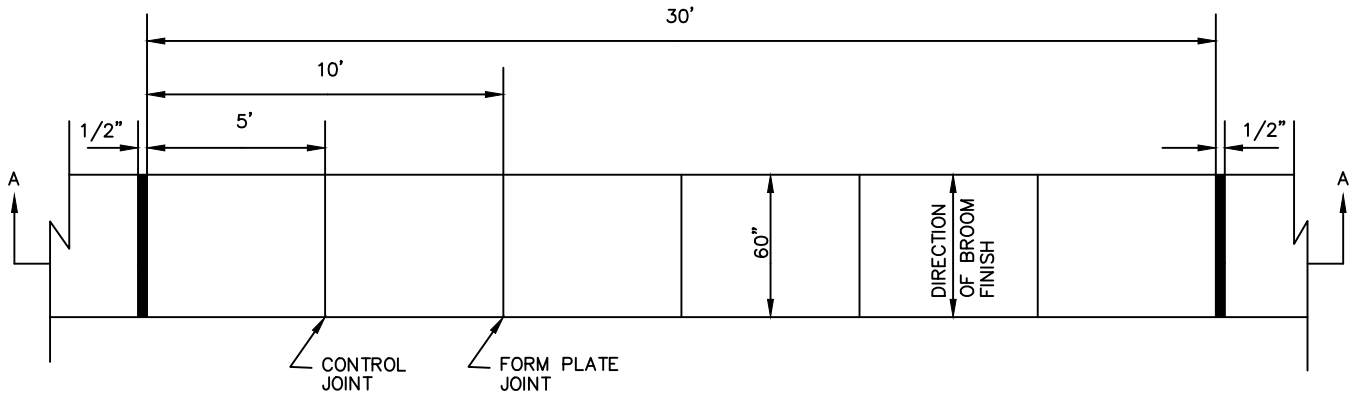

PLAN VIEW

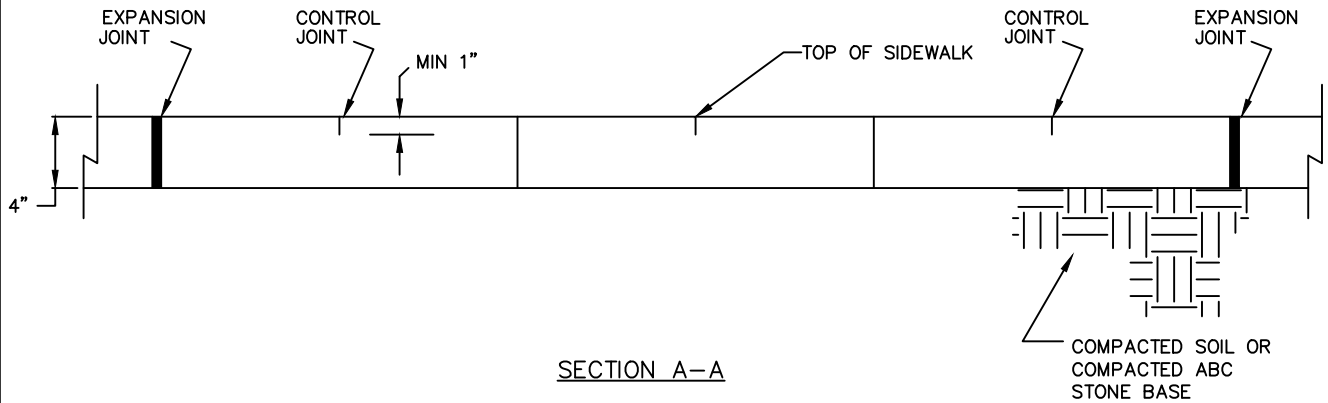

SECTION A-A

- NOTE:
1. CONCRETE SHALL HAVE A COMPRESSIVE STRENGTH OF 3000 PSI AT 28 DAYS
 2. SURFACE SHALL BE ROUGH NON-SKID TYPE
 3. ALL SIDEWALKS SHALL HAVE CROSS-SLOPE OF 1/4" PER FOOT TO DRAIN TOWARD STREET.

NOT TO SCALE



CITY OF HICKORY
SIDEWALKS

SHEET 1 OF 1

DATE:
2-1-07

STD. NO.
409

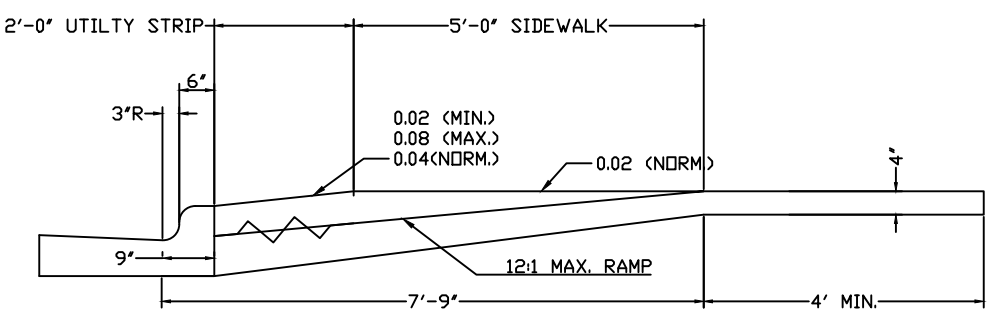
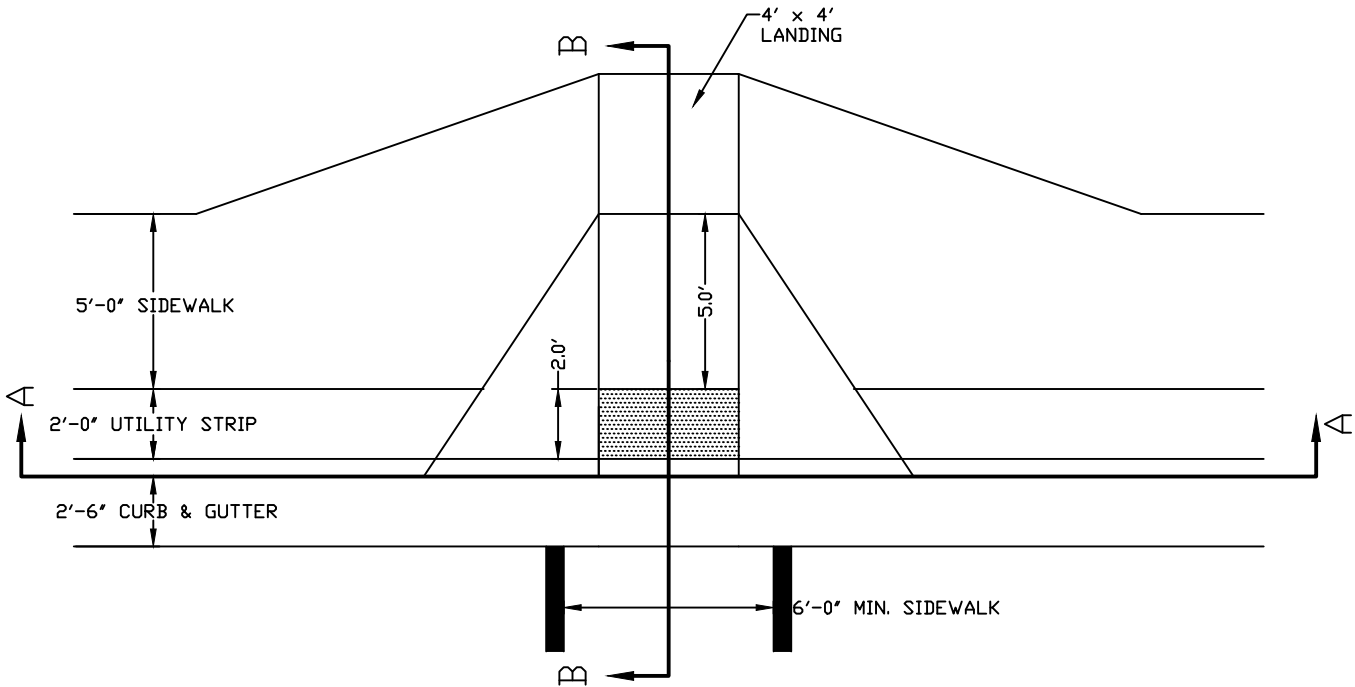

SECTION
B-B

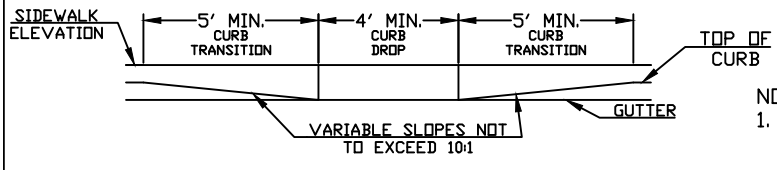

- NOTES:
1. DETECTABLE WARNING DOMES WILL COVER 2'-0" LENGTH AND FULL WIDTH OF THE RAMP FLOOR AS SHOWN.
 2. DETECTABLE WARNING DOMES WILL CONTRAST VISIBILITY WITH ADJOINING SURFACE, EITHER LIGHT-ON-DARK, OR DARK-ON-LIGHT SEQUENCE COVERING THE ENTIRE RAMP.

NOT TO SCALE



CITY OF HICKORY

STANDARD WHEELCHAIR RAMP

SHEET 1 OF 3

DATE:
11-28-17

STD. NO.
410

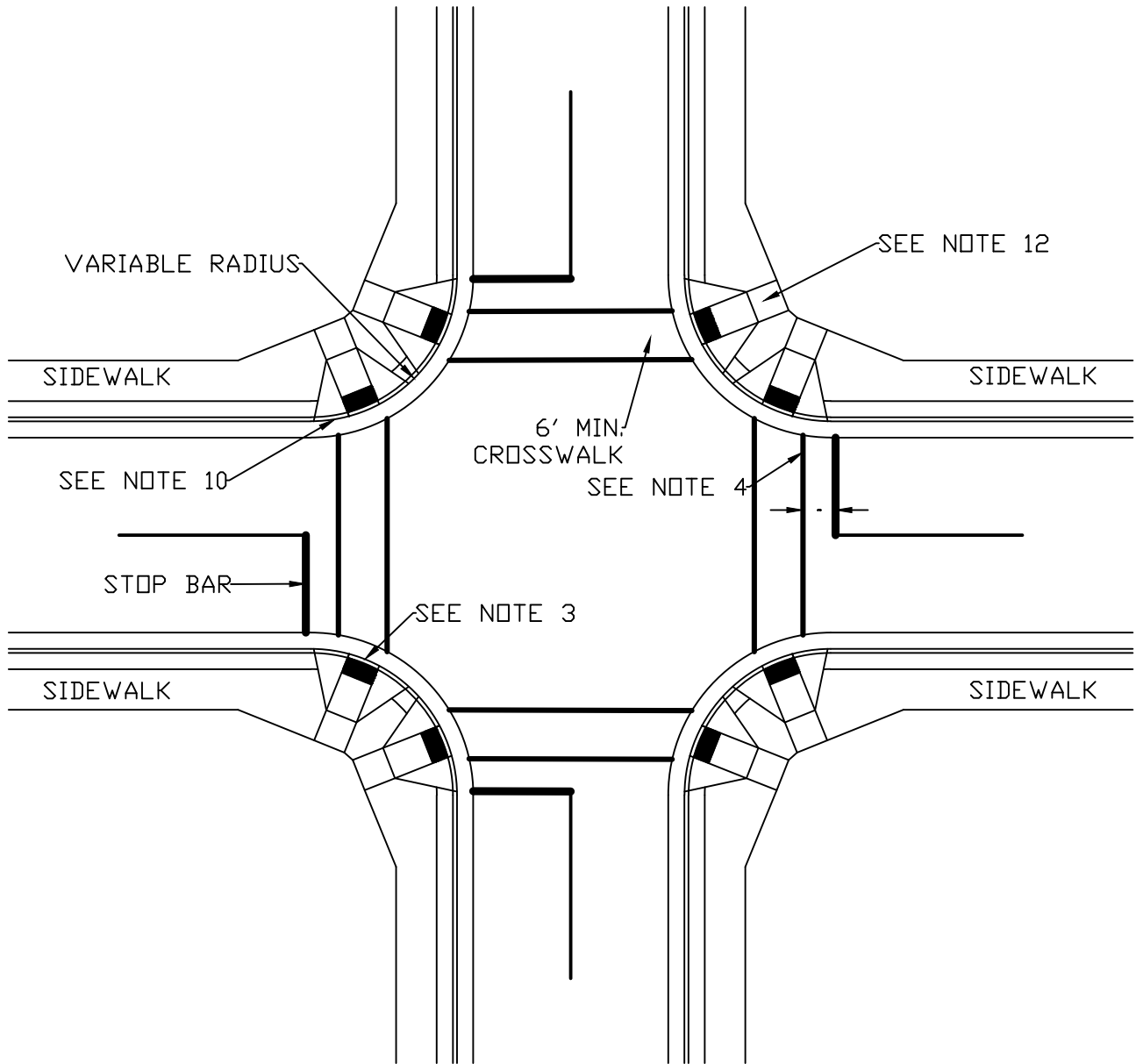

DETAIL SHOWING TYPICAL LOCATION OF CURB RAMPS, PEDESTRIAN CROSSWALKS AND STOP BARS

NOT TO SCALE



CITY OF HICKORY

STANDARD WHEELCHAIR RAMP

SHEET 2 OF 3

DATE:
11-28-17

STD. NO.
410

NOTES:

1. CONSTRUCT THE RAMP SURFACE TO BE STABLE, FIRM, AND SLIP RESISTANT. CONSTRUCT THE CURB RAMP TYPE AS SHOWN IN THE PAVEMENT MARKING PLANS OR AS DIRECTED BY THE ENGINEER.
2. LOCATE CURB RAMPS AND PLACE PEDESTRIAN CROSSWALK MARKINGS AS SHOWN IN THE PAVEMENT MARKING PLANS. WHEN FIELD ADJUSTMENTS REQUIRE MOVING CURB RAMPS OR MARKINGS AS SHOWN, LOCATE AS DIRECTED BY THE ENGINEER.
3. COORDINATE THE CURB RAMP AND THE PEDESTRIAN CROSSWALK MARKINGS SO A 4'x4' CLEAR SPACE AT THE BASE OF THE CURB RAMP WILL FALL WITHIN THE PEDESTRIAN CROSSWALK LINES.
4. SET BACK DISTANCE FROM INSIDE CROSSWALK MARKING TO NEAREST EDGE OF TRAVEL LANE IS 4' MINIMUM.
5. REFER TO THE PAVEMENT MARKING PLANS FOR STOP BAR LOCATIONS AT SIGNALIZED INTERSECTIONS. IF A PAVEMENT MARKING PLAN IS NOT PROVIDED, LOCATE AS DIRECTED BY THE ENGINEER.
6. TERMINATE PARKING A MINIMUM OF 20' BACK OF A PEDESTRIAN CROSSWALK.
7. CONSTRUCT CURB RAMPS A MINIMUM OF 4' WIDE.
8. CONSTRUCT THE RUNNING SLOPE OF THE RAMP 8.33% MAXIMUM.
9. ALLOWABLE CROSS SLOPE ON SIDEWALKS AND CURB RAMPS WILL BE 2% MAXIMUM.
10. CONSTRUCT THE SIDE FLARE SLOPE A MAXIMUM OF 10% MEASURED ALONG THE CURB LINE.
11. CONSTRUCT THE COUNTER SLOPE OF THE GUTTER OR STREET AT THE BASE OF THE CURB RAMP A MAXIMUM OF 5% AND MAINTAIN A SMOOTH TRANSITION.
12. CONSTRUCT LANDINGS FOR SIDEWALK A MINIMUM OF 4'x4' WITH A MAXIMUM SLOPE OF 2% IN ANY DIRECTION. CONSTRUCT LANDINGS FOR MEDIAN ISLANDS A MINIMUM OF 5'x5' WITH A MAXIMUM SLOPE OF 2% IN ANY DIRECTION.
13. TO USE A MEDIAN ISLAND AS A PEDESTRIAN REFUGE AREA, MEDIAN ISLANDS WILL BE A MINIMUM OF 6' WIDE. CONSTRUCT MEDIAN ISLANDS TO PROVIDE PASSAGE OVER OR THROUGH THE ISLAND.
14. SMALL CHANNELIZATION ISLANDS THAT CAN NOT PROVIDE A 5'x5' LANDING AT THE TOP OF A RAMP WILL BE CUT THROUGH LEVEL WITH THE SURFACE STREET.
15. CURB RAMPS WITH RETURNED CURBS MAY BE USED ONLY WHERE PEDESTRIANS WOULD NOT NORMALLY WALK ACROSS THE RAMP, THE ADJACENT SURFACE IS PLANTING OR OTHER NON-WALKING SURFACE OR THE SIDE APPROACH IS SUBSTANTIALLY OBSTRUCTED.
16. PLACE A ½" EXPANSION JOINT WHERE THE CONCRETE CURB RAMP JOINS THE CURB.
17. PLACE ALL PEDESTRIAN PUSH BUTTON ACTUATORS AND CROSSING SIGNALS AS SHOWN IN THE PLANS OR AS SHOWN IN THE MUTCD.
18. CURB RAMPS THROUGH MEDIAN ISLANDS, SINGLE RAMPS AT DUAL CROSSWALKS OR LIMITED R/W SITUATIONS WILL BE HANDLED BY SPECIAL DETAILS AND DESIGN BY THE ENGINEER.

NOT TO SCALE



CITY OF HICKORY

STANDARD WHEELCHAIR RAMP

SHEET 3 OF 3	
DATE: 11-28-17	STD. NO. 410

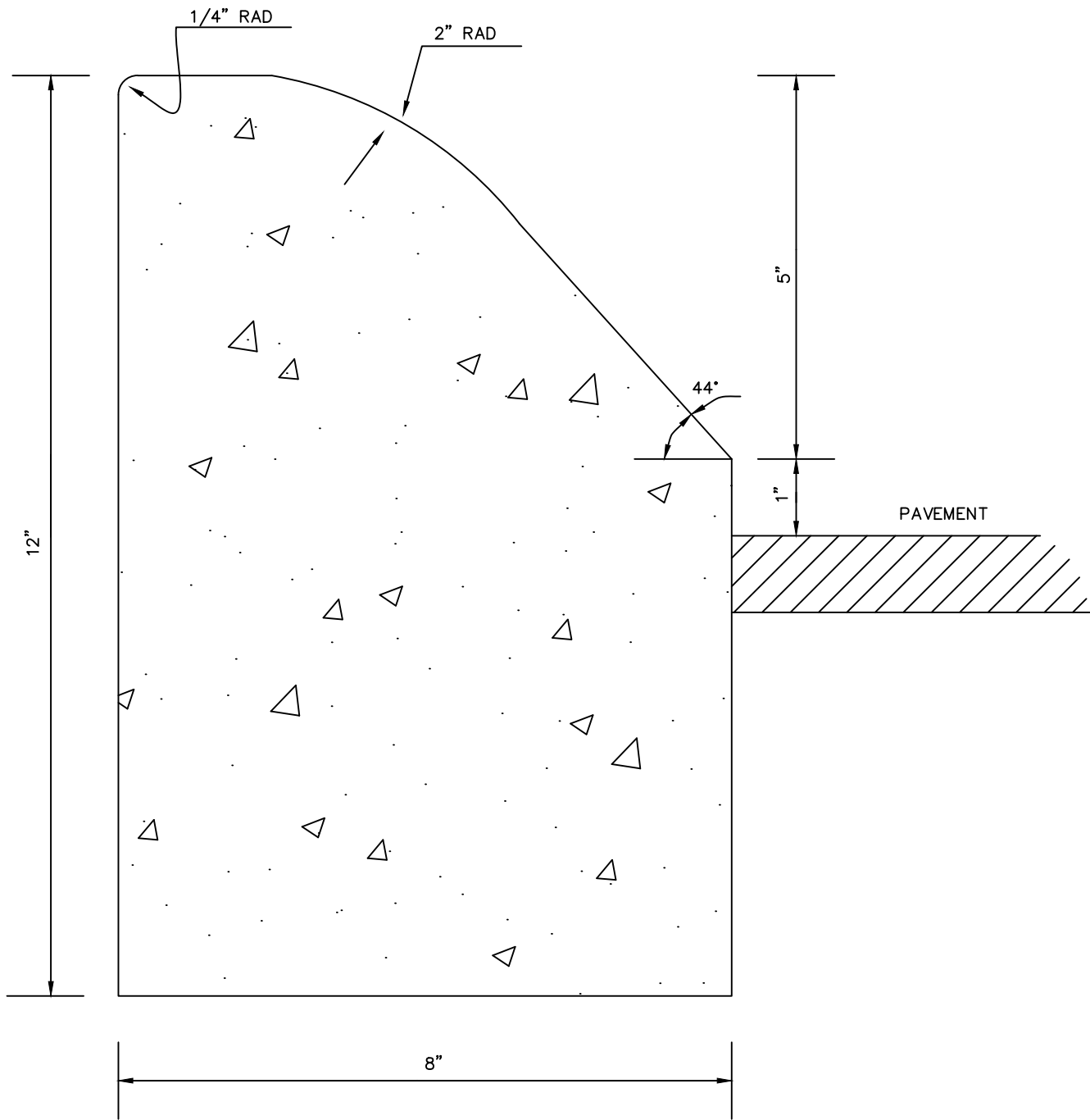

NOTE- *EXPANSION JOINT EVERY 40' & CONST. JOINT EVERY 10'

NOT TO SCALE



CITY OF HICKORY

8" X 12" MEDIAN CURB

SHEET 1 OF 1

DATE:
2-1-07

STD. NO.
411

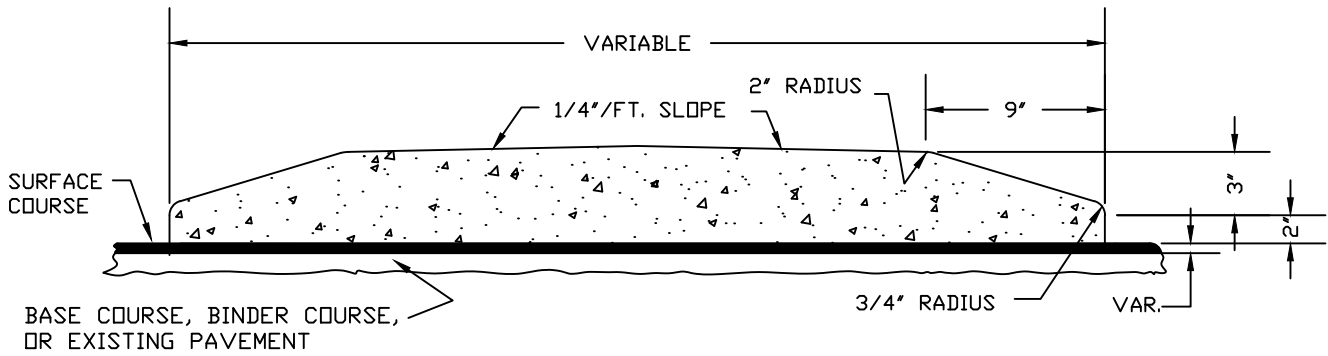

5" MONOLITHIC CONCRETE ISLAND ON BITUMINOUS PAVEMENT
 (USE ON ISLAND 4' WIDE OR GREATER)

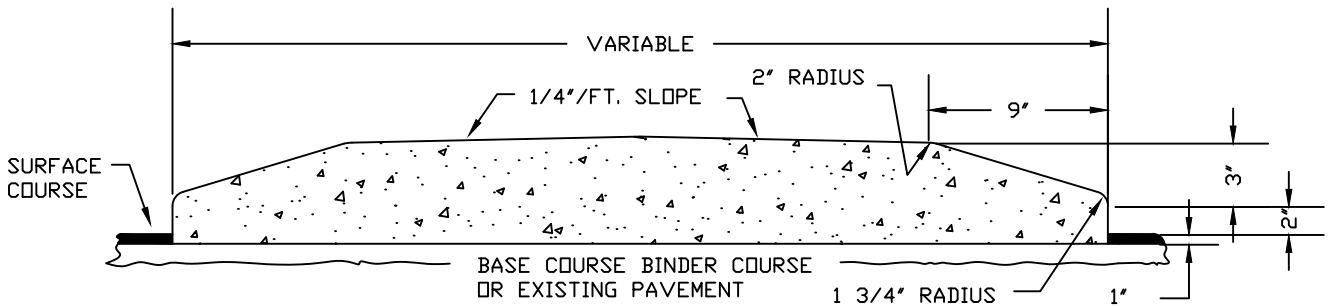

MONOLITHIC CONCRETE ISLAND ON BITUMINOUS PAVEMENT
 (USE ON ISLAND LESS THAN 4' WIDE)

NOT TO SCALE



CITY OF HICKORY

CONCRETE ISLANDS

DATE:
2-1-07

SHEET 1 OF 3
 STD. NO.
412

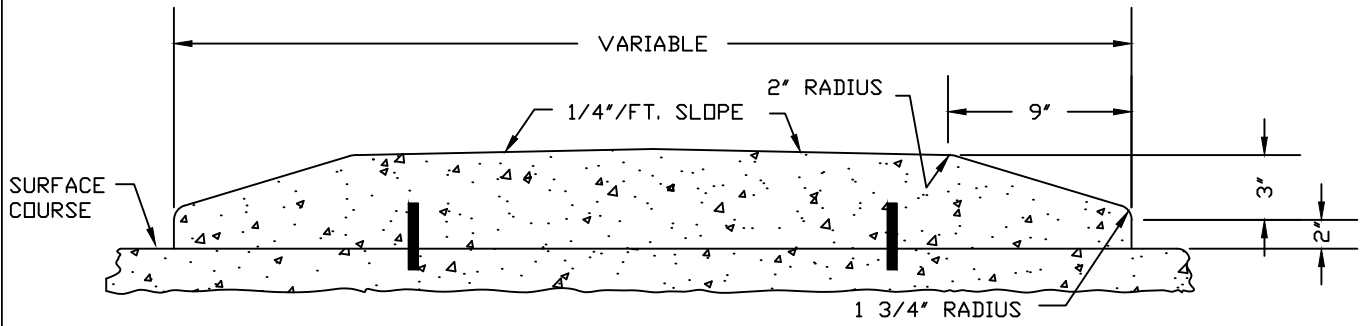

5" MONOLITHIC CONCRETE ISLAND ON PORTLAND CEMENT CONCRETE PAVEMENT
 (USE ON ISLAND 4' WIDE OR GREATER)

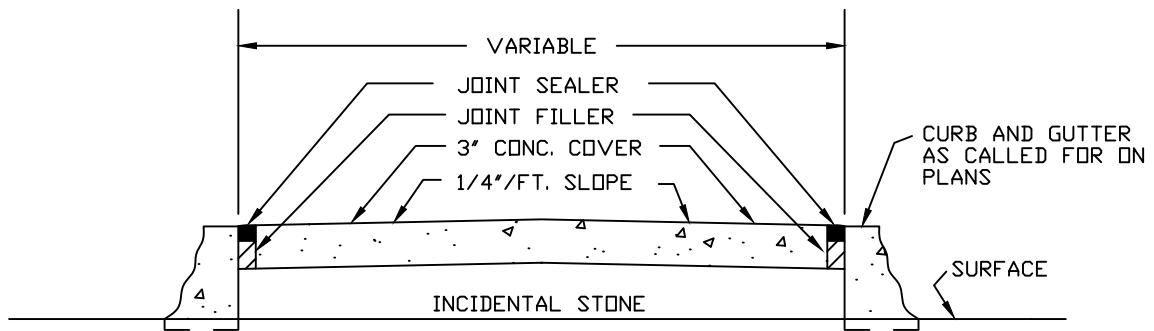

PAVED CONCRETE ISLAND

NOT TO SCALE



CITY OF HICKORY

CONCRETE ISLANDS

SHEET 2 OF 3

DATE:
2-1-07

STD. NO.
412

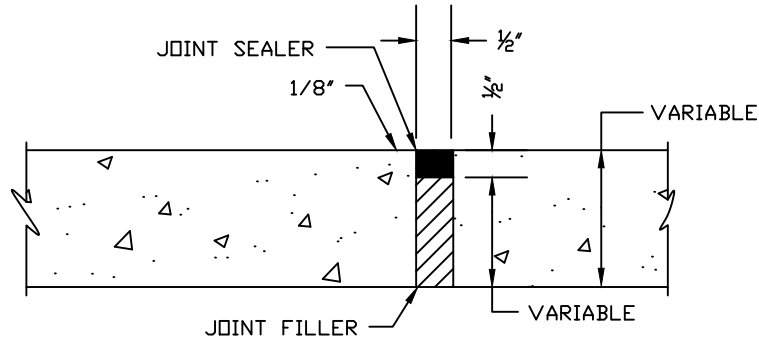

SHOWING EXPANSION JOINT

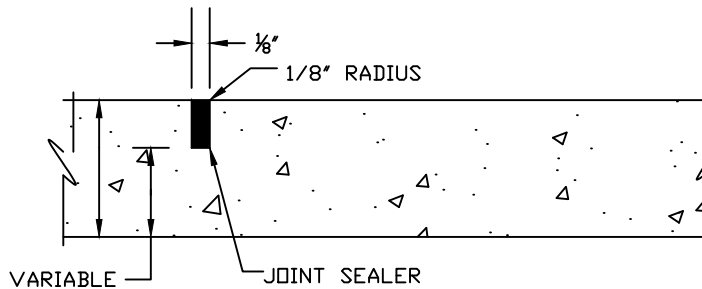

SHOWING GROOVED JOINT

PART LONGITUDINAL SECTION
OF PAVED ISLANDS

NOTE:
 WHEN MONOLITHIC CONCRETE ISLAND IS ON TOP OF SURFACE COURSE 40D SPIKES SHALL BE DRIVEN INTO SURFACE UNDER MONOLITHIC CONCRETE ISLANDS. SPIKES SHALL BE STAGGERED ON 2' CENTERS EACH WAY.
 IN THE CONCRETE PAVEMENT (ISLAND) AND CONCRETE ISLAND (MONOLITHIC) PLACE 1/2" EXPANSION JOINTS AT 30' INTERVALS AND GROOVED JOINTS 1" DEEP AT 10' INTERVALS BETWEEN EXPANSION JOINTS.
 THE JOINTS IN THE CONCRETE PAVEMENT (ISLAND) SHALL LINE UP WITH THE JOINTS IN THE CURB OR CURB AND GUTTER. THE TOP 1/2" OF THE EXPANSION JOINTS AND THE ENTIRE DEPTH OF GROOVED JOINTS SHALL BE FILLED AND SEALED WITH JOINT SEALER.

NOT TO SCALE



CITY OF HICKORY

CONCRETE ISLANDS
JOINT DETAILS

SHEET 3 OF 3

DATE:
2-1-07

STD. NO.
412

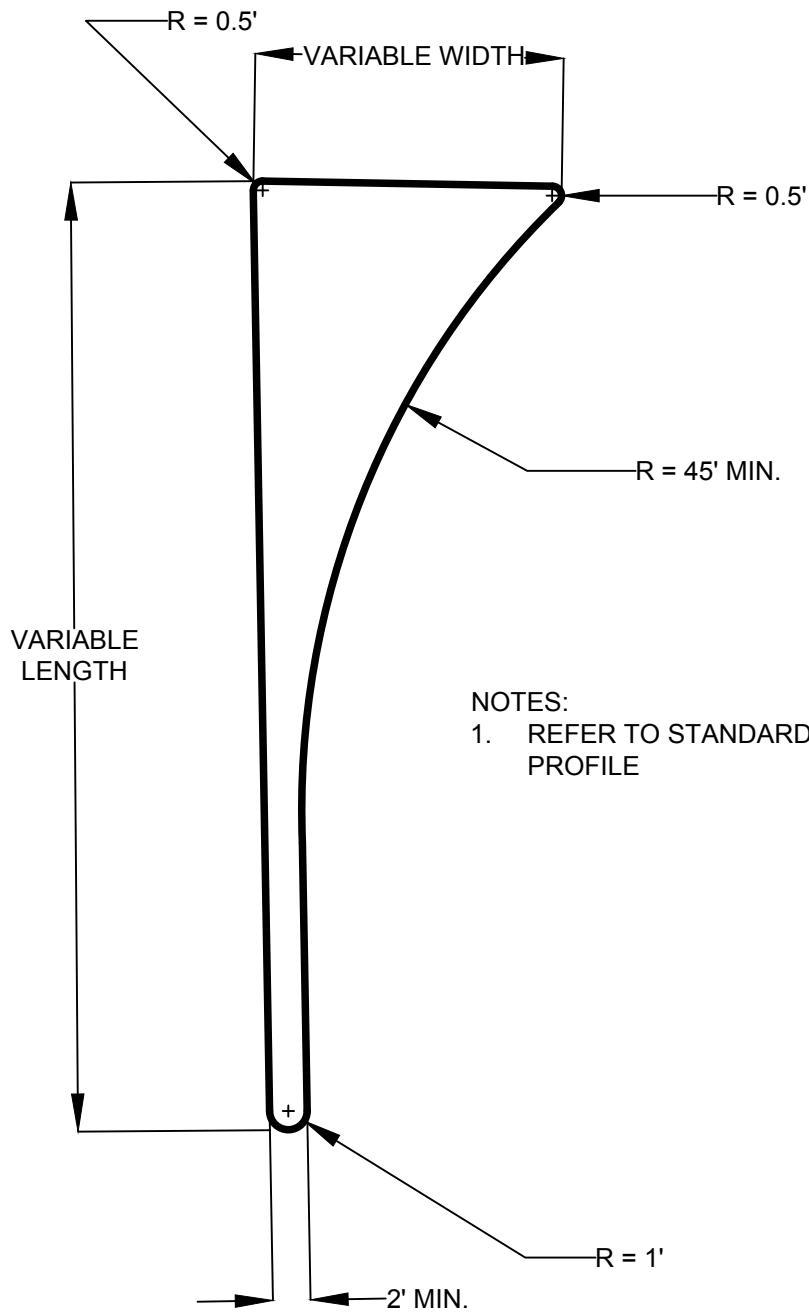

NOT TO SCALE



CITY OF HICKORY
 CHANNELIZED RIGHT TURN
 CONCRETE ISLAND

SHEET 1 OF 1

DATE:
12-04-17

STD. NO.
413

ISLAND NOTES:

1. 7" TOTAL THICKNESS IF DOWELLED INTO ASPHALT PER NCDOT STD. 852.01
2. 9" TOTAL THICKNESS IF KEYED INTO ASPHALT PER NCDOT STD. 852.01
3. ISLAND WIDTH VARIES DIRECTLY WITH APPROACH ROAD WIDTH

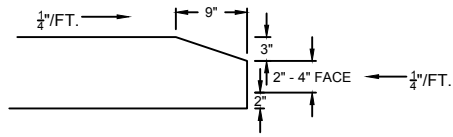

ISLAND SECTION

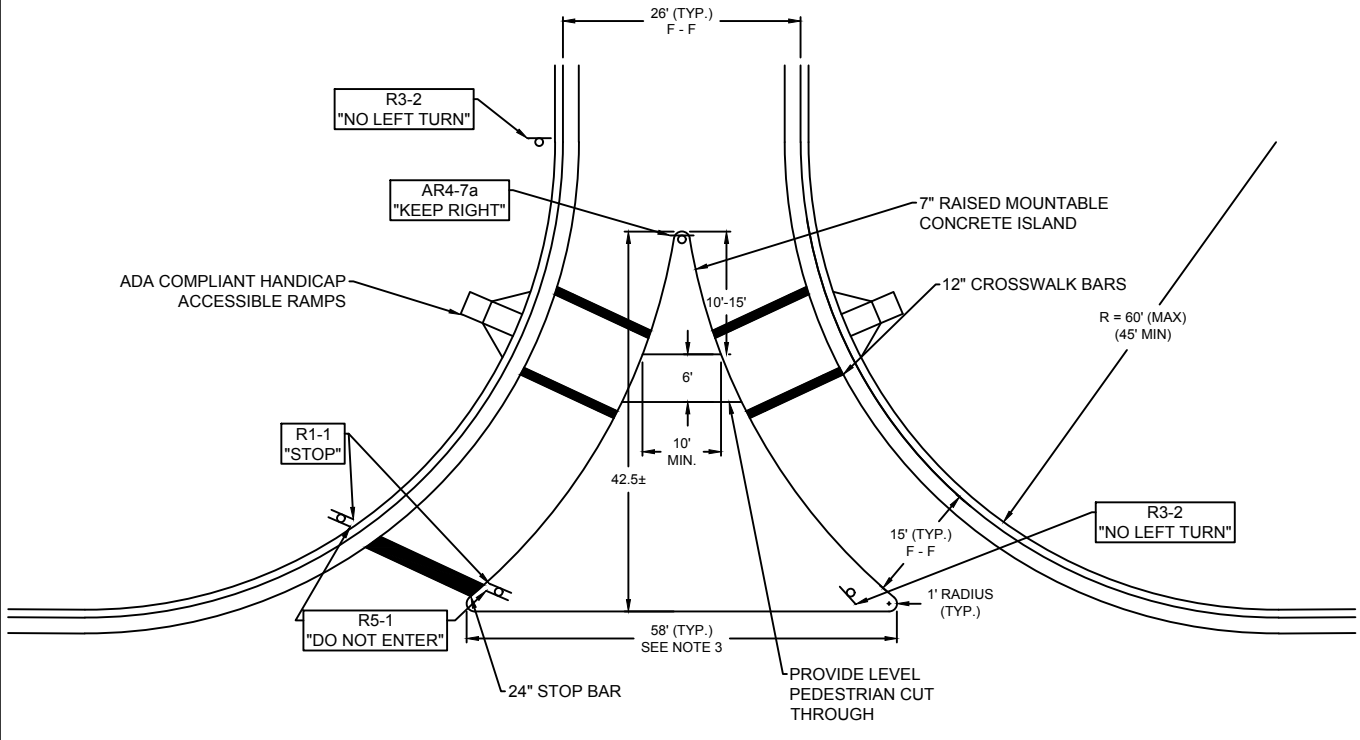

RIGHT-IN/RIGHT-OUT STANDARD

NOT TO SCALE



CITY OF HICKORY

RIGHT-IN/RIGHT-OUT
DRIVEWAY STANDARD

SHEET 1 OF 1

DATE:
12-04-17

STD. NO.
414

Engineering Department
Manual Of
Practice



Life. Well Crafted.

500 Water Systems

Section 2660 – WATER SYSTEM

1.1 INTRODUCTION

The scope of this section is to furnish all labor, equipment, materials and all other items that are customary and normally required to install and complete installation of ductile iron, polyvinyl chloride (PVC) and copper water lines in accordance with the plans. All pipe and incidental material shall be of the type specified in the plans and these specifications unless written variance is granted by the Engineer. All pipe storage/handling, excavation, bedding, laying, jointing and backfilling shall be accomplished as specified herein. Payment shall be made as depicted in the unit prices and measured as the actual laying length with no deduction for valves or fittings.

1.2 CATALOG CUTS SUBMITTALS

Contractor shall submit 4 copies of catalog cuts to Engineer for review for all materials that are required to complete the work as described in the associated plans. Engineer will retain two sets of original submittals and return two sets to the Contractor with the appropriate response annotated.

1.3 STORAGE AND HANDLING

The Contractor shall inspect the materials upon receipt for visible defects prior to off loading. The Contractor shall unload pipe so any deformation or other injury to the pipe is avoided. The Contractor shall implement appropriate measures during storage such that no storm water may pass through or encumber the materials. Pipe shall not be rolled or dragged over gravel, rock, asphalt or concrete during handling or staging. In the event of damaged material, the damaged section may be cut away from the undamaged section and disposed of with the undamaged portion being used. The Engineer may reject material that is severely damaged or injured in whole or part. In no event shall any pipe or material be placed along the project site by rolling off a truck or trailer and allowed to strike the ground. Stringing pipe or material in this manner will damage the pipe, material, lining or casting of same and will be deemed defective and rejected by the Engineer.

If defective material is discovered after installation, it shall be removed and replaced or repaired with acceptable materials by the Contractor at their sole expense.



CITY OF HICKORY

GENERAL NOTES FOR
WATER SYSTEMS

DATE:
3-18-08

SHEET 1 OF 13
STD. NO.
501

1.1 MATERIALS

- A. Pipe size less than 3” diameter that is installed below grade and outside building shall comply with one or more of the following:
1. Seamless Copper Tubing: Type “K” roll form to comply with ASTM B 88-62 and installed with wrought copper (95-5 Tin Antimony solder joints) fittings in accordance with ANSI B16.22.
 2. Polyvinyl Chloride Water Pipe: Pipe shall conform to ASTM D 2241 with SDR 21 rating or SDR 13.5 and shall be continually marked with manufacturer’s name, pipe size, cell classification, SDR rating and ASTM

Section 2660 - 1

3. D 1784 classification. Pipe joints shall be integrally molded bell ends in accordance with ASTM D 3139 with factory supplied elastomeric gaskets and lubricant.
 4. PVC pipe in this classification shall be stamped with current NSF marking for “Potable Water Use”.
- B. Pipe size larger than 3” that is installed below grade and outside building shall comply with one of the following as depicted on the plans:

1. Ductile Iron Pipe:
All materials shall be true to theoretical form throughout, first quality with smooth interior and exterior and free from imperfections. All materials shall be available for inspection by the Engineer/Owner at any point from production to installation for the purpose of rejecting defective materials or altering to meet intended specification. All rejected material shall be immediately removed from the project site upon written notice from the Engineer.

All cited or referenced specifications or standards shall be the latest revisions under that identification or in the case of abandoned standards any such superseding standard. This shall be true for all specifications or standards except such requirements that clearly are not applicable.

Ductile iron pipe shall be manufactured in accordance with AWWA Standard C 151. All Ductile iron pipe shall be class 350 psi unless specified differently on the plans and shall contain a cement mortar lining, unless specified differently on the plans, not less than 1/16” thick as specified in AWWA Standard C 104. Wall thickness for all ductile iron pipes shall be in conformance with AWWA Standard C 150. Standard laying conditions shall be assumed to be type 2 unless specified differently

on the plans. The exterior of pipe shall be coated to a thickness of not less than 5 mils, as specified in AWWA Standards C 110 & C 115, with an asphaltic material.

1 a. Flanged Joints

Flanged pipe shall have flanges with long hubs, shop fitted on the threaded end of pipe, shall be 125 lb. rated and accurately faced at right angles to the pipe axis so a complete fit is readily obtained. When required, flanges shall be tapped for stud bolts. The face of all flanges shall be drilled smooth and true and completely coated with coal tar finish, varnish or other approved anti-corrosion agent. Immediately prior to installation, flange faces shall be cleaned with a wire brush until the face is significantly consistent of bare metal.

Section 2660 – 2

Ductile iron flanged joint pipe shall conform to AWWA Standards C 110 & C 115 and shall have a minimum thickness of Class 53. Flanged end pipe shall be accurately measured and ordered so that not field cutting of pipe is necessary unless specifically approved by the Engineer. Unless approved no field alteration of flanged pipe will be allowed. Attempts to field cut pipe shall result in immediate rejection of all material affected. All flanged joints shall be properly aligned with no external force applied to the pipe or flange to achieve alignment. All bolts and gaskets shall be furnished by the Contractor installing the pipe for all joints, including such joints as the Contractor may be connecting to equipment or appurtenances which they did not supply or install.

Flanged joints shall be jointed with properly sized and type bolts as recommended by the manufacturer. Stud or tap bolts shall be used only as indicated on the plans. Steel or tap bolts shall be cadmium plated with true and sound fitting threads. Cadmium plating shall be by an approved process with a thickness of 3 to 5/ 10,000 of an



CITY OF HICKORY

GENERAL NOTES FOR
WATER SYSTEMS

SHEET 3 OF 13

DATE:
3-18-08

STD. NO.
501

inch. The Contractor upon request shall supply written confirmation of plating to the Engineer.

1.b. Mechanical Joints:

All mechanical joint pipe shall be manufactured in accordance with AWWA Standard C 111, C 151 and C150 as applicable with a rating of class 350 psi.

All bolts shall be finish tightened by means of a torque wrench to the specified torque as recommended by the manufacturer in such a manner as the pipe is sealed evenly around to the joint. If effective sealing is not obtained by following the above procedures then the joint shall be disassembled, cleaned and reassembled following the above procedures.

Bolts shall be high-grade steel, low alloy type with tee head and American Standard threads. Mechanical joint gland shall be cast iron and gasket shall be plain rubber.

Section 2660 – 3

1.c. Slip Joints:

Slip joint pipe shall be manufactured in accordance with AWWA Standards C 151 & C 150 as applicable with a rating of class 350 psi.

Bells of pipe shall be contoured to receive a bulb shaped circular rubber gasket and spigot end shall have sufficient taper to facilitate installation. Jointing shall be achieved by lubricating joint with approved lubricant, guiding spigot end of pipe into bell end of



CITY OF HICKORY

GENERAL NOTES FOR
WATER SYSTEMS

SHEET 4 OF 13

DATE:
3-18-08

STD. NO.
501

enough compressive force to drive the spigot forward into the bell until they achieve full contact. No joint shall exceed the maximum deflection allowed by the manufacturer, normally 8" in an 18' joint.

1.d. Restrained Joint:

Restrained joints shall consist of standard ductile iron slip bell with gaskets containing metal wedges. Wedges shall be manufactured of stainless steel and the gasket rubber shall be manufactured in accordance with ANSI/AWWA C 111/A21.11. Bells shall be manufactured in accordance with ANSI/AWWA C 153/A21.53. The joints shall be designed for a working pressure of 200 psi. Restrained joints shall be American "Fast Grip", U.S. Pipe "Field-Lok", or approved equal.

1.e. Ball and Socket Joints:

When specified ductile iron ball and socket joint pipe shall conform to AWWA Standards C 150 & C 151 as applicable and shall have a minimum thickness class of 55. The spherical socket shall be manufactured with applicable material requirements of ASTM A 536 and threaded onto the ductile iron pipe barrel with threads conforming to ANSI B2.1 adapted to standard ductile iron pipe. The ball end of joint shall be integrally cast with the pipe barrel and accurately machined to fit into the adjoining pipe socket and provide constant compression of the gasket through deflection of up to 15 degrees of the assembled joint and shall maintain a watertight joint in all directions. The inside surface of the ball shall be shaped so that the waterway shall not be significantly impacted at any degree of deflection. A substantial external locking ductile iron gland shall prevent longitudinal separation.

Ball and Socket joints shall be American "Flex-Lok", U.S. Pipe "USIFLEX", or approved equal.

Section 2660 – 4

	CITY OF HICKORY	
	GENERAL NOTES FOR WATER SYSTEMS	SHEET 5 OF 13 DATE: 3-18-08 STD. NO. 501

1. Fittings:

All ductile iron fittings shall be in conformance with AWWA Standards C 110 & C 111 for underground piping as applicable and shall be mechanical joint type unless otherwise specified on the plan. If flanged pipe is specified then it shall be in conformance with AWWA Standard C 110 for exposed piping.

All fittings shall be manufactured in conformance with AWWA Standards C 111 & C 104 as applicable and shall be cement mortar lined unless otherwise specified on the plans. All fittings shall have rated working pressure of 250 psi unless otherwise specified on the plans.

2. Polyvinyl Chloride Pipe (PVC)

All materials shall be true to theoretical form throughout, first quality with smooth interior and exterior and free from imperfections. All materials shall be available for inspection by the Engineer/Owner at any point from production to installation for the purpose of rejecting defective materials or altering to meet intended specification. All rejected material shall be immediately removed from the project site upon written notice from the Engineer.

All cited or referenced specifications or standards shall be the latest revisions under that identification or in the case of abandoned standards any such superseding standard. This shall be true for all specifications or standards except such requirements that clearly are not applicable.

3.a PVC Pipe 4” Diameter and Larger:

All PVC pipe 4” and larger shall be manufactured in conformance with AWWA Standard C 900 and shall conform to the requirements of DR 18 class 150 psi or DR 14 class 200 psi. The exterior of all PVC shall bear a continuous stamp indicating the AWWA certification, DR ratio, size and manufacturer.

All PVC shall have a bell with integral rubber gasket and be slip joint manufactured in accordance with AWWA C 151.



CITY OF HICKORY

GENERAL NOTES FOR
WATER SYSTEMS

DATE:
3-18-08

SHEET 6 OF 13
STD. NO.
501

Bells of pipe shall be contoured to receive a bulb shaped circular rubber gasket and spigot end shall have sufficient taper to facilitate installation. Jointing shall be achieved by lubricating joint with approved lubricant, guiding spigot end of pipe into bell end of adjacent pipe until contact is made with gasket and exerting enough compressive force to drive the spigot forward into the bell until they achieve full contact. No joint shall exceed the maximum deflection allowed by the manufacturer, normally 11” in a 20’ joint.

Section 2660 - 5

1. Fittings:

All ductile iron fittings shall be in conformance with AWWA Standards C 110 & C 111 for underground piping as applicable and shall be mechanical joint type unless otherwise specified on the plan. If flanged pipe is specified then it shall be in conformance with AWWA Standard C 110 for exposed piping.

All fittings shall be manufactured in conformance with AWWA Standards C 111 & C 104 as applicable and shall be cement mortar lined unless otherwise specified on the plans. All fittings shall have rated working pressure of 250 psi unless otherwise specified on the plans.

1.1 INSTALLATION

A. Excavation

This section shall cover the excavation and proper disposal of any and all materials disturbed during the construction of trenches which is further defined as all excavation necessary for the proper installation storm or sanitary sewers and any appurtenances and waterlines and any appurtenances. This section shall further cover any work deemed appropriate by the Engineer.

Excavation shall be done to the lines and grades as depicted or detailed on the plans or as directed by the Engineer. All work involving this section shall be coordinated with any Grading, Site Utility work or other construction on the project site and shall be maintained satisfactorily so that adequate drainage is provided at all times. Any roots that protrude into the trench lines shall be trimmed flush with the trench walls.



CITY OF HICKORY

GENERAL NOTES FOR
WATER SYSTEMS

SHEET 7 OF 13

DATE:
3-18-08

STD. NO.
501

All excavation shall be open cut unless otherwise depicted on the plans or specifically authorized by the Engineer. If after excavation the bottom of the proposed trench is found to contain rock, materials which can not be removed with standard and prudent construction equipment or is unsuitable for providing a uniform bearing surface then same material shall be removed to a depth not less than 8” below proposed depth, back filled with approved material and compacted. Excavation widths shall be such that not less than one full diameter of the pipe is clear between the outside face of the pipe and each closest trench wall or inside face sheeting, shoring, or trench box as necessary.

Excavated materials to be used during backfill operation shall be suitable material, significantly free from debris and/or rocks and approved by the Engineer. Acceptable material which is excavated shall be neatly and compactly deposited at the sides of the trench where space provides but at no time closer than 2’ 0” from the closest side of the trench. When stockpiling of material is required, the Contractor at his expense shall do so at an approved site and this site shall be kept and neat to avoid unsightly appearance. Stockpiling shall be arranged to allow for natural drainage without pollution of water by erosion.

Section 2660 – 6

Protection of existing pavement structures from damage due to staining from excavated material and to improve cleanup shall be obtained by placing a 1” layer of sand or rock dust over all asphalt or concrete surfaces which are planned or reasonably anticipated to have excavated material directly on during construction.

A. Sheeting, Bracing and Trench Boxes

As appropriate reference to OSHA Regulation 1926.652(b), the Contractor will be required to keep the sides of excavation vertical by sheet, bracing or the use of trench boxes to prevent movement by slides or settling of the side, to prevent injury or displacement of pipe or appurtenance or diminished the required working space adjacent to pipe. Furthermore, the Contractor may be required, for the purpose of preventing injury to persons, property or adjacent structures, to leave sheeting or bracing in place.



CITY OF HICKORY

GENERAL NOTES FOR
WATER SYSTEMS

SHEET 8 OF 13

DATE:
3-18-08

STD. NO.
501

All measures employed, when required, shall extend a minimum of 18” above existing grade and a maximum of 48” above grade. In no case shall timbers, beams or other sheeting/bracing materials be left in the trench, which may form or promote voids that cannot easily be corrected during the backfilling operation or compaction of backfill. It is agreed upon by these specifications that where it is necessary to leave sheeting or bracing intact and backfilled that the Owner is under no obligation to pay Contractor for time or materials involved in constructing such measures. Contractor shall assume and accept any and all risk associated with or encumbered by failure to implement proper and necessary sheeting, bracing or trench box use on any excavation and will be held responsible for caving, settlement and all other damages resulting there from.

A. Foundations

Trench foundation shall be “Type 2” as defined in AWWA Standard C 151 unless otherwise noted on the plans. Pipe bedding shall be as shown in the plans for the typical cross section for the type of pipe and location for which it is being installed. Pipe foundation shall be uniformly firm and compacted and shall be consistent with lines and grades as detailed on the plans.

Section 2660 - 7

Trench bottom shall be formed to follow the bottom third of the pipe, where soil conditions allow. All installations shall conform to a uniform bearing surface throughout the length of the pipe to fully and evenly support the barrel of the pipe. Bell holes shall be excavated under each bell of each joint such that no undue stress is born by the bell of pipe thus leading to damage of the material. If undercut is required due to unsuitable soil, rock or through normal construction then suitable material shall be replaced and compacted with uniform support of the pipe provided for the entire length of the pipe. At no time shall undercut for rock be less than 8" from the proposed grade so to prevent future damage. Undercut limits for unsuitable material for supporting pipe loading shall be determined by and constructed according the Engineer. Continued unsuitable soil may require replacing bottom of trench to grade with washed stone or in extreme cases concrete cradles. If washed stone or concrete cradles are specified then the Engineer at unit price for materials shall allow additional compensation to the Contractor.

The Contractor shall remove all water that may be encountered or which may accumulate in the trenches by pumping or bailing and no pipe shall be laid until the water has been successfully removed from the trench. Water so removed from the trench shall be disposed of in a manner as not to cause injury to completed work, work in progress or any adjoining area.

A. Installing Pipe:

All installation practices should be in strict conformance with the manufacturers recommendations, AWWA Standard C 600 and the construction specifications. Where any conflicts exist the Contractor shall inform the Engineer immediately and AWWA Standard C 600 shall take precedence. The Engineer shall be furnished installation manuals for any such product that a discrepancy arises or they deem appropriate.

Customary and reasonable tools, implements and facilities satisfactory to the Engineer shall be provided and used for the safe and progressive installation of pipe. All pipe, fittings, valves and other materials shall be hoisted into trench by means which are acceptable and are not conducive to injury of pipe, fittings, valves, and any other materials or there protective coatings or dangerous to any personnel who may be in the trench or vicinity. All pipe hoisted into the trench shall be clean and free from defects. Pipe shall be laid on the prepared foundation so as a straight, uniform flow line exists upon completion.



CITY OF HICKORY

GENERAL NOTES FOR
WATER SYSTEMS

SHEET 10 OF 13	
DATE: 3-18-08	STD. NO. 501

When cutting pipe lengths are necessary, the Contractor shall practice normal and prudent care so that all cuts are at right angles to the flow line of the pipe. If a skewed cut is specified then the Contractor shall perform the cut as required by the plans. All slip joint pipe which is cut shall be ground to a taper on the cut end to match the manufacturers taper so pipe may be jointed as intended by the manufacturer.

Section 2660 – 8

All PVC pipe installed shall be chased continuously with a 14 gauge stranded, coated copper wire with the coating being royal or light blue. Wire shall be pulled taut so as to prevent damage from backfill and compaction operation or re-excavation in the future. Wire shall be taped no less than every 10 feet and at the taper of every bell end. Wire shall be pulled into every valve box with no less than 2x the depth of bury in length of wire left in the box for future connection to facilitate location. Wire shall be extended in an identical manner along fire hydrant legs and extended along the barrel to ground surface and looped around the base of the upper section at the flange.

Pipe joints shall be sound and in strict compliance with the manufacturers recommendations. Maximum deflection allowed shall be as allowed by the manufacturer but at no time should be greater than 2 degrees or 8” per 18’ joint without special expanded deflection bells being provided. All pipe which is damaged, broken or will not join shall be removed immediately and stockpiled for inspection by the Engineer. Pipe that is damaged during backfill or compaction operations shall be removed and replaced or repaired as directed by the Engineer.

All water lines shall have a minimum 12” vertical separation from storm sewer and shall have a minimum vertical separation of 18” from sanitary sewer when crossing. When crossing sanitary sewer lines the waterline shall cross above the sanitary sewer line. Horizontal separation of 10’ 0” shall be maintained from all sanitary sewers. If separations cannot be maintained then the Engineer shall be notified and both the waterline and sanitary sewer line shall be constructed of ferrous material such as ductile iron.



CITY OF HICKORY

GENERAL NOTES FOR
WATER SYSTEMS

SHEET 11 OF 13

DATE:
3-18-08

STD. NO.
501

Pipe shall not be installed except in the presence of the Engineer or at his specific direction. In the event pipe is installed without the specific direction of the Engineer, then the Contractor may be required to clean, test, uncover for inspection or remove the sections as directed by the Engineer.

1.1 BACKFILL AND COMPACTION

A. Trenches shall be back filled immediately upon approval of pipeline construction.

B. Roadways and Crossing

Full depth and width of trench shall be back filled by placing material in uniform layers not to exceed 12” thick and shall be thoroughly compacted by approved mechanical compactors under optimum moisture conditions. Compaction of the trench shall be to 95% as determined by Standard Proctor Test for all areas outside the paved area and any depth exceeding 18” below finished surface of asphalt. The top 18” of any trench directly under pavement or within 36” of the edge of pavement shall be compacted to 100% as determined by Standard Proctor Test. If existing material is not suitable for obtaining compaction then select back fill shall be used when requested by the Engineer.

Section 2660-9

All paving and base course affected shall be removed and replaced with new material of equal or better quality with like texture and color as the adjacent pavement.

All back fill methods shall be in strict compliance with manufactures recommendations and all methods shall be instituted such that no damage, misalignment, or unjointing of the pipe or appurtenances is experienced. Backfill shall be kept free of organics (grasses, sticks, stumps, roots etc.), stones (all stones over 1” diameter within first 12” of backfill and all stones over 2.5” diameter for the remainder of the backfill), any frozen soil or other soil which is not suitable for backfill (highly plastic clay) or any other objectionable items. All back fill shall be installed and graded in a manner that erosion or saturation will not negatively affect the back filled area.



CITY OF HICKORY

GENERAL NOTES FOR
WATER SYSTEMS

SHEET 12 OF 13

DATE:
3-18-08

STD. NO.
501

Heavy equipment shall not be operated over any pipe or appurtenance until it has been properly backfilled and has minimum cover as required by the plans. Where any part of the required cover is above proposed finished grade, the Contractor shall place, maintain and lastly remove such material at no additional cost to the Owner. Any pipe or appurtenance, which becomes mis-aligned, shows excessive settlement or has been damaged by the Contractor shall be corrected or replaced as deemed necessary by the Engineer/Owner at no additional cost to the Owner.

Prior to acceptance, the Contractor shall properly maintain all installations in such a manner that they will operate without failure.

A. Finish Grading

All areas disturbed shall be graded to a continuous finish without irregularities or abrupt changes and shall not consist of areas, which will retain water or cause foreseeable future maintenance. Prior to acceptance, all debris, excess material, trash or any unsightly occurrence shall be removed and the project site shall be in a neat and satisfactory condition.

Cleanup and seeding is part of the pipeline installation. No more than 4,000 lf of waterline may be laid prior to completion of cleanup of the first section of pipeline laid. During construction no more than 4,000 lf or 2 weeks time may pass before cleanup and seeding is performed.

END SECTION

Section 2660 - 10



CITY OF HICKORY

GENERAL NOTES FOR
WATER SYSTEMS

SHEET 13 OF 13

DATE:
3-18-08

STD. NO.
501

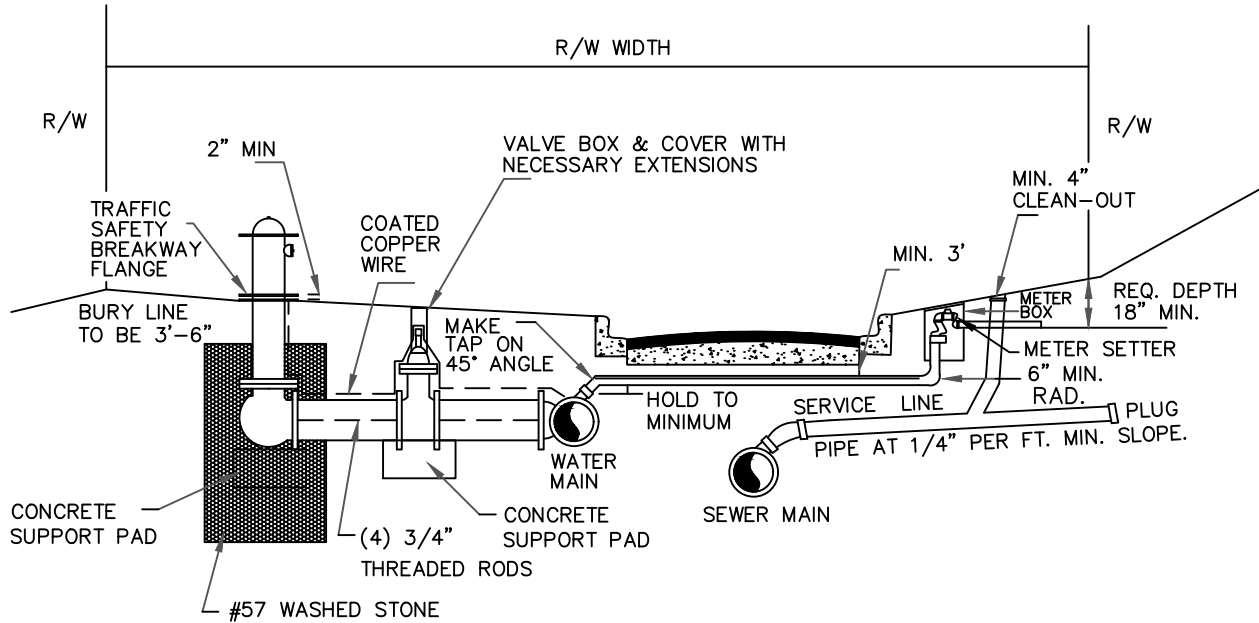

NOTE:

1. ADD 14GA COATED COPPER WIRE CONTINUOUS ALONG MAIN WITH 24" SLACK IN & OUT OFF ALL VALVE BOXES

NOT TO SCALE



CITY OF HICKORY

TYPICAL RESIDENTIAL CONNECTION AND HYDRANT SETTING DETAIL

SHEET 1 OF 1

DATE:
2-1-07

STD. NO.
502

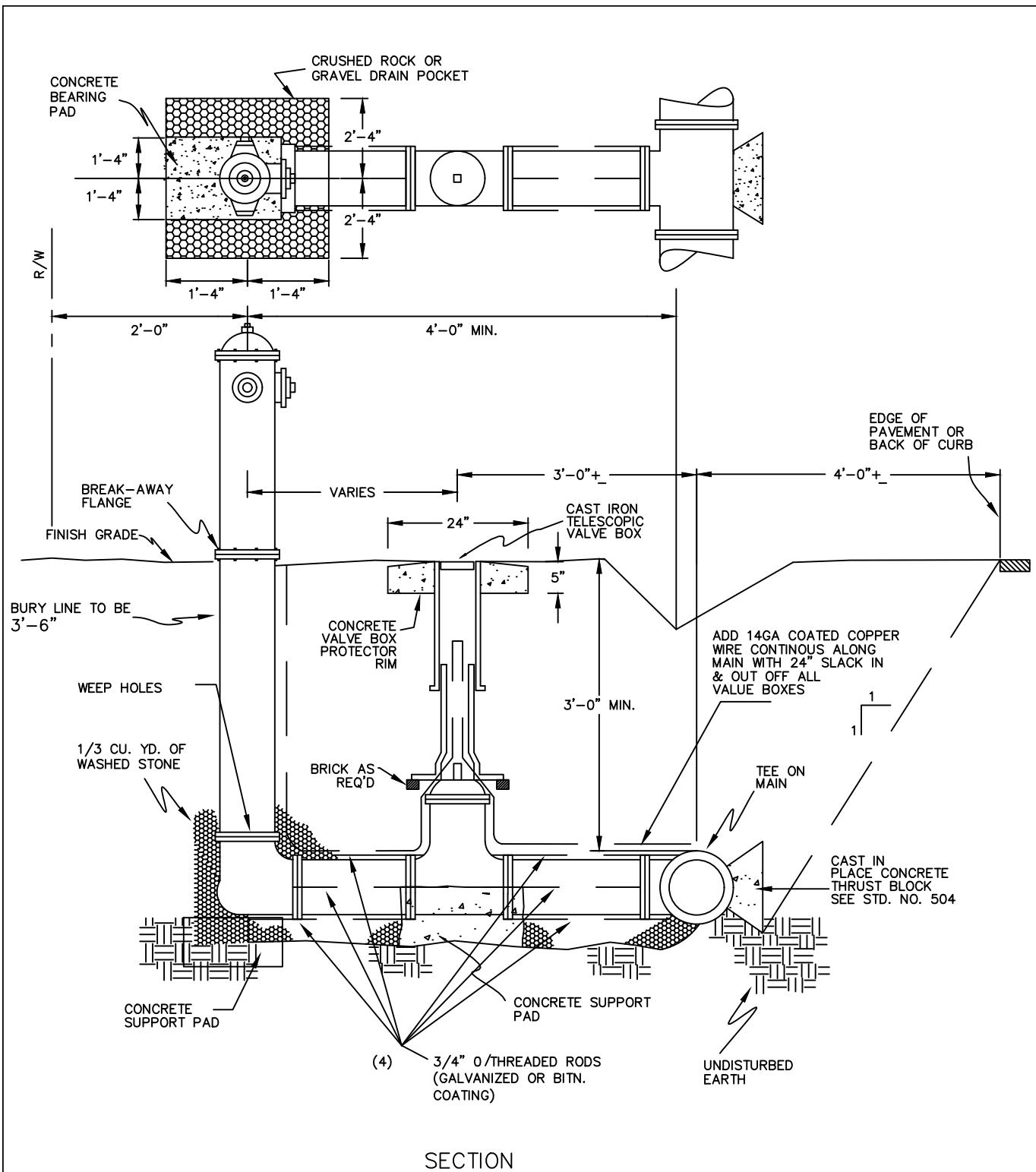

SECTION

- NOTES: FIRE HYDRANTS SHALL BE ONE OF THE FOLLOWING THREE TYPES WITH THE 4 1/2" PUMPER NOZZLES BEING NATIONAL STANDARD PIPE THREADS AND 2 (TWO) 2 1/2" HOSE NOZZLES BEING NATIONAL STANDARD THREADS.
- A) CENTURION, MANUFACTURED BY MUELLER COMPANY
 - B) SUPER CENTURION, MANUFACTURED BY MULLER COMPANY
 - C) MARK-73 TRAFFIC MODEL, MANUFACTURED BY AMERICAN CAST IRON PIPE COMPANY

NOT TO SCALE

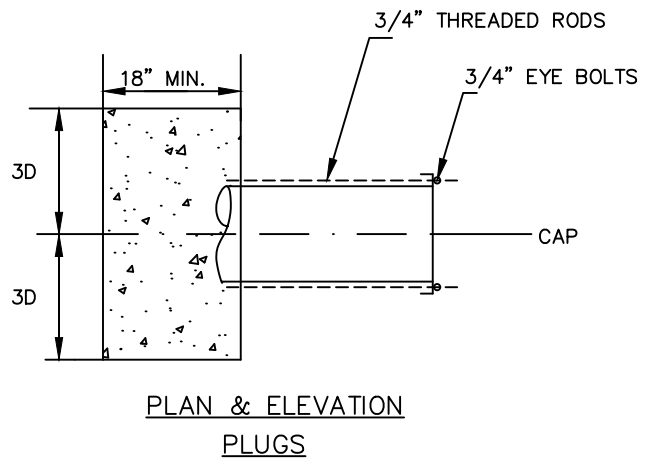
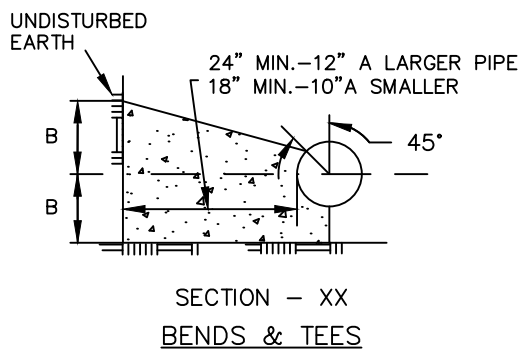
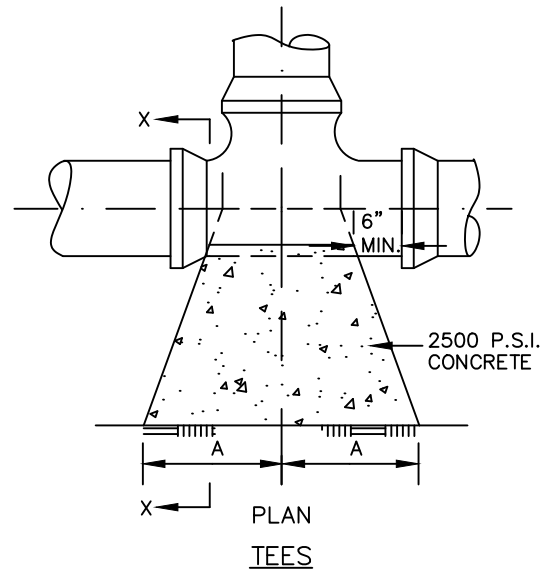
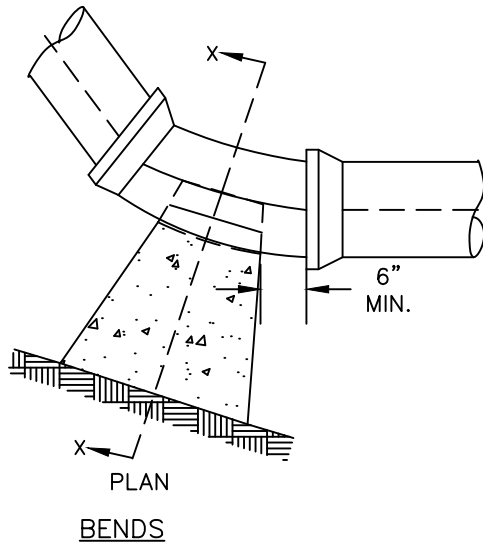

NOTES:

1. DEAD MAN RESTRAINED
W/ 2-3/4" ALL THREAD
RODS 3" TO 8" AND 4-3/4"
ALL THREAD RODS 12" TO 16"

PIPE SIZE	11 1/4° BEND		22 1/2° BEND		45° BEND		90° BEND		TEE	
	A	B	C	D	A	B	A	B	A	B
6	9	10	12	10	16	10	20	10	10	12
8	12	13	16	13	22	13	26	13	13	16
12	16	21	22	21	28	21	32	21	18	24
16	21	27	30	27	36	27	44	27	24	32

ALL DIMENSIONS IN TABLE ARE IN INCHES.
NOTE: WHERE WORKING PRESSURES EXCEED 150 PSI.
AWWA STANDARDS SHALL APPLY.

NOT TO SCALE



CITY OF HICKORY
THRUST BLOCK FOR WATER MAINS
(150 PSI WORKING PRESSURE)

SHEET 1 OF 1

DATE:
2-1-07

STD. NO.
504

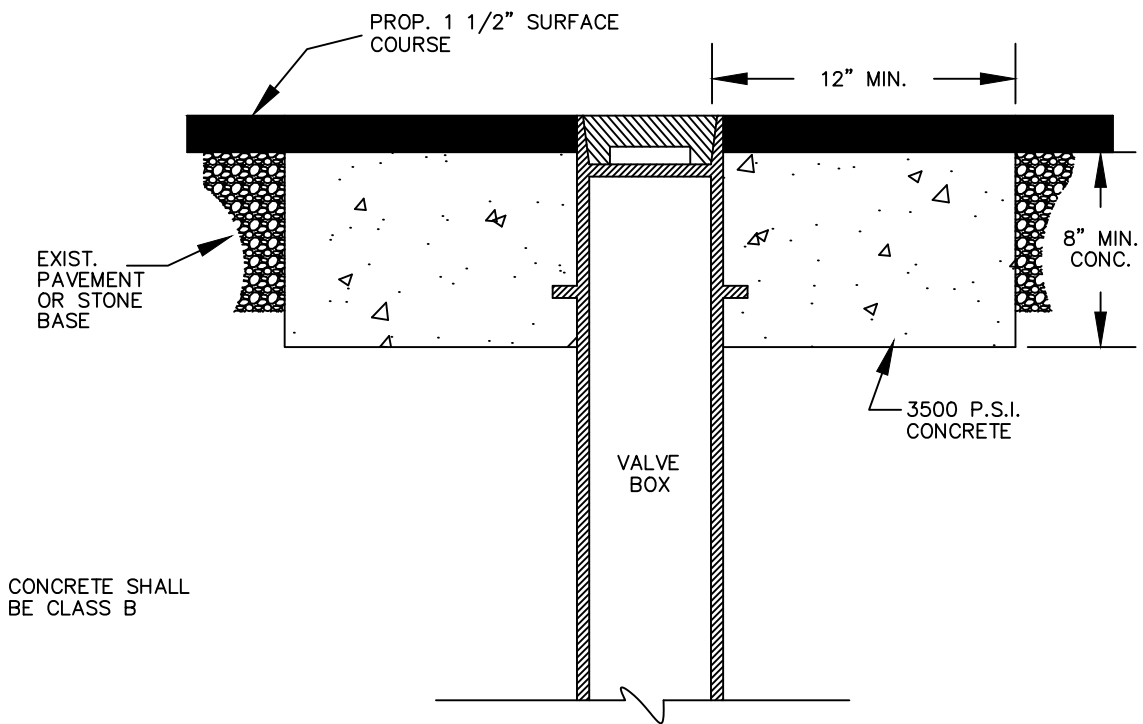

CONCRETE SHALL
BE CLASS B

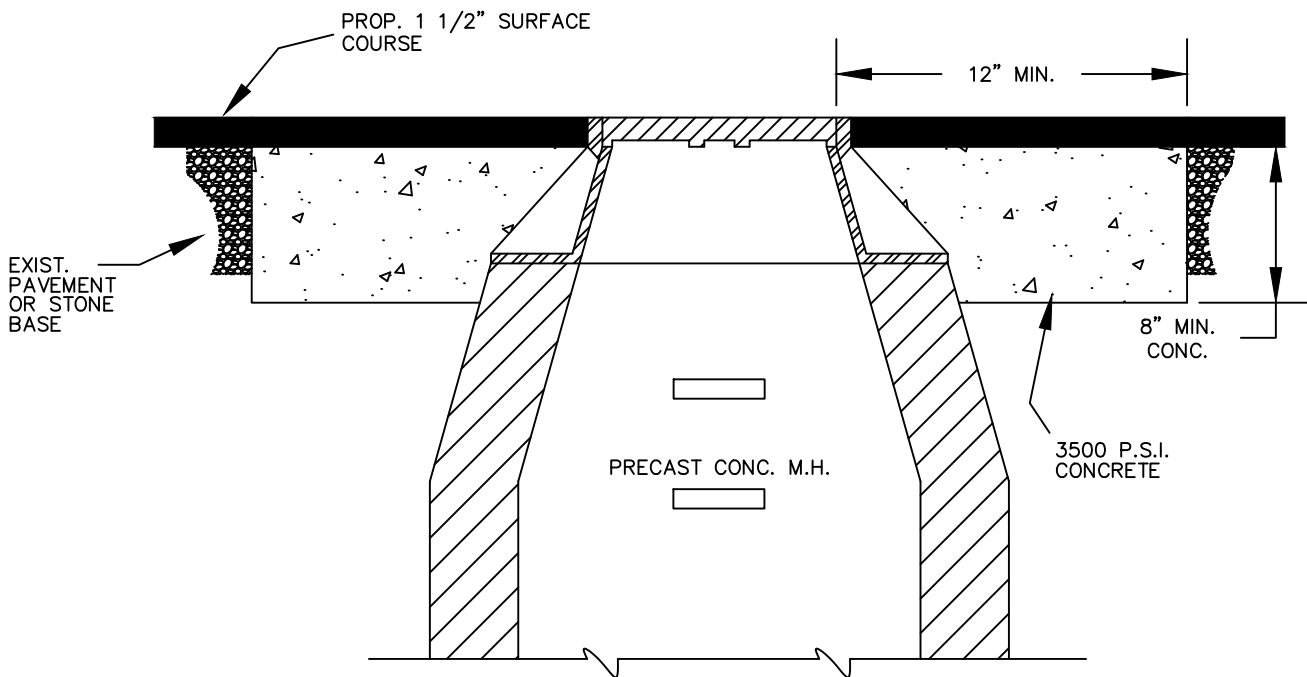

NOT TO SCALE



CITY OF HICKORY
CONCRETE ENCASEMENT FOR MANHOLE
& CASTINGS IN PAVEMENT

SHEET 1 OF 1

DATE:
2-1-07

STD. NO.
505

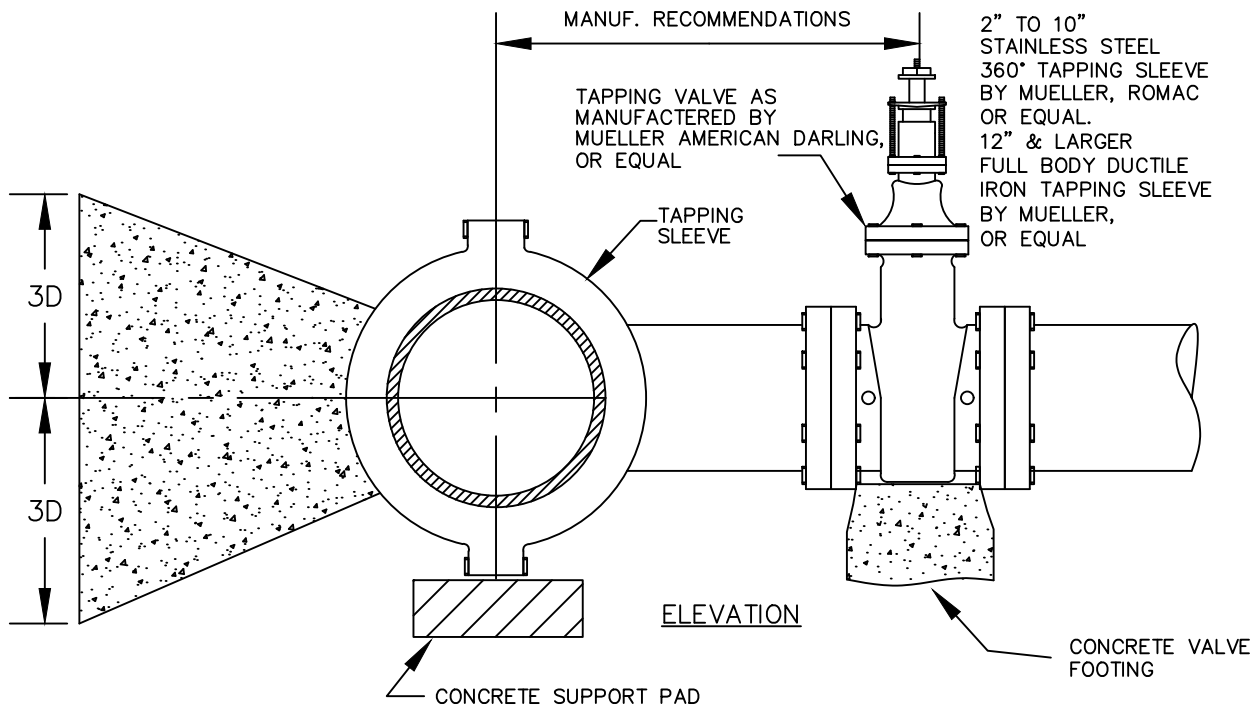
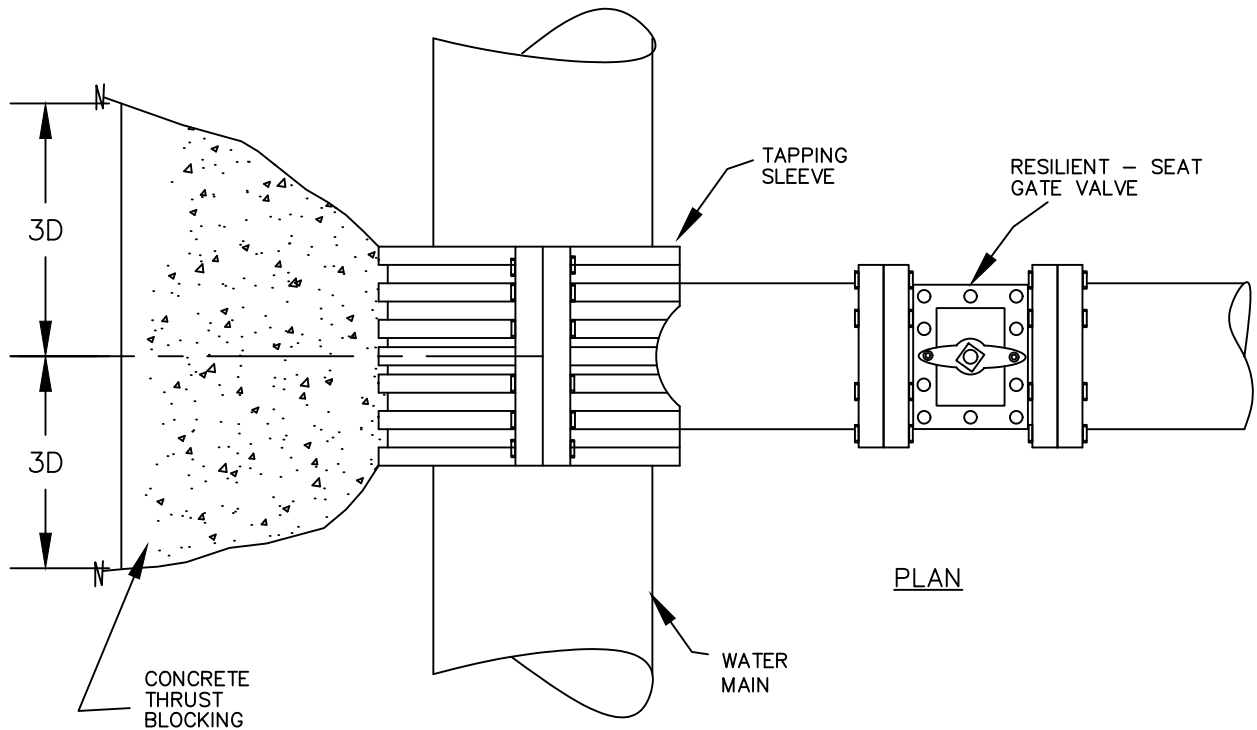

NOTES

1. CONCRETE SHALL NOT CONTACT BOLTS OR ENDS OF MECHANICAL JOINT FITTING.
2. SEE STANDARD THRUST BLOCK TABLES, SEE STD. NO. 870 #504 FOR AREA OF CONCRETE REQUIRED.

NOT TO SCALE



CITY OF HICKORY

TAPPING SLEEVE & VALVE ASSEMBLY

SHEET 1 OF 1

DATE:
2-1-07

STD. NO.
506

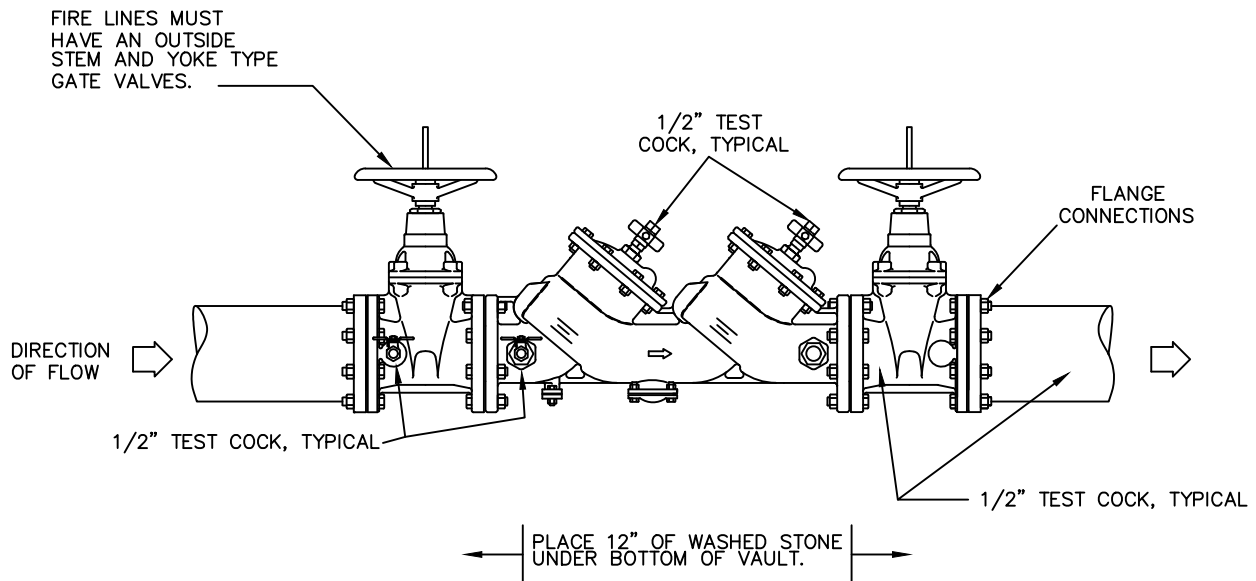

NOTES:

1. 4" AND LARGER PVC PIPE APPLICATIONS SHALL REQUIRE GATE AND CHECK VALVE ASSEMBLY TO BE SUPPORTED BY A CRADLE.
2. 6" AND LARGER DUCTILE IRON PIPE APPLICATIONS SHALL REQUIRE GATE AND CHECK VALVE ASSEMBLY TO BE SUPPORTED BY A CRADLE.
3. VAULTS FOR GATE AND CHECK VALVE ASSEMBLY SHALL PROVIDE ADEQUATE INSIDE CLEARANCE TO FACILITATE INSTALLATION, REMOVAL, AND MAINTANCE W/ MINIMUM OF 18" CLEAR IN ALL DIRECTIONS. SUBMITTALS TO CITY OF HICKORY ARE REQUIRED.
4. TYPICALLY VAULTS SHALL BE CONSTRUCTED IN NON-TRAFFIC AREAS, ADJACENT TO RIGHT OF WAY LINE.
5. RPZ SHALL BE SUBSTITUTED W/ IDENTICAL LAYOUT WHERE REQUIRED. VAULT DRAIN SHALL BE PLUMBED TO STORM DRAIN WHERE AVAILABLE.

NOT TO SCALE

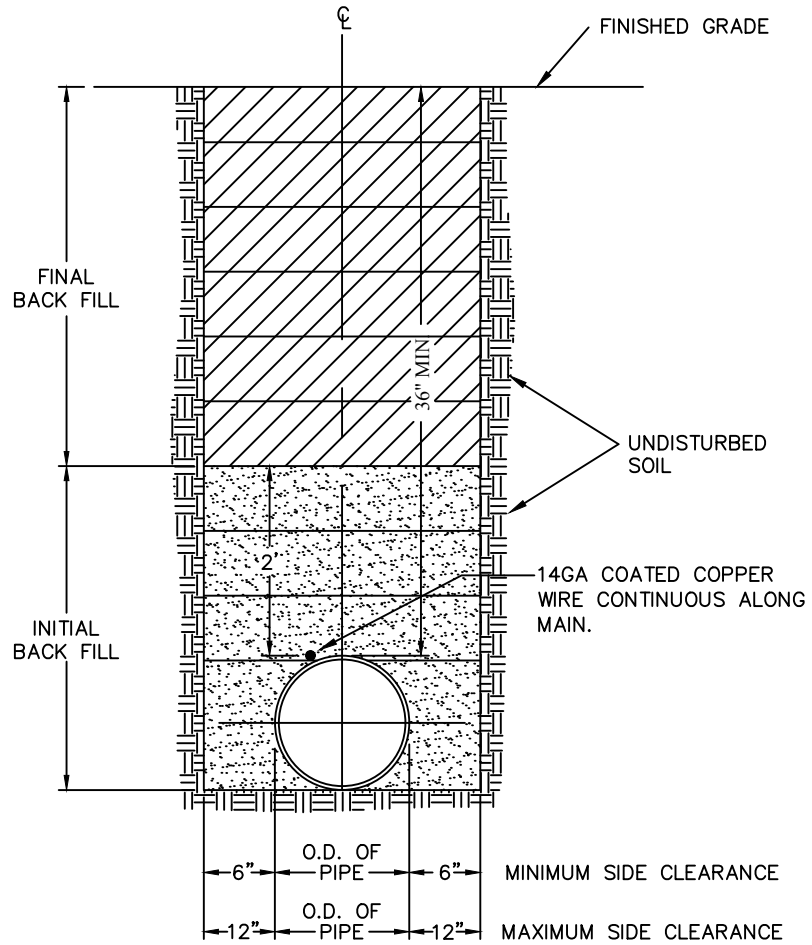

TYPICAL TRENCH BOTTOM DIMENSIONS FOR:
DUCTILE IRON, C-900 PVC, AND CONCRETE PIPE

TRENCH DETAIL
CLASS D FLAT SUBGRADE

NOTES:

1. TRENCHES REQUIRING SHORING AND BRACING, DIMENSIONS SHALL BE TAKEN FROM THE INSIDE FACE OF THE SHORING AND BRACING.
2. NO ROCKS OR BOULDERS 2" OR LARGER TO BE USED IN INITIAL BACKFILL.
3. ALL BACKFILLED MATERIAL SHALL BE SUITABLE MATERIAL.
4. BACK FILL SHALL BE COMPACTED IN 6" LAYERS IN TRAFFIC AREAS, 12" LAYERS IN NON-TRAFFIC AREAS USING VIBRATORY EQUIPMENT.

DEPTH OF BEDDING
MATERIAL BELOW PIPE

D	d (MIN.)
27" & SMALLER	6"
30" - 60"	12"
66" & LARGER	18"

NOT TO SCALE



CITY OF HICKORY

WATER LINE TRENCH BOTTOM DIMENSIONS
AND BACKFILLING REQUIREMENTS

SHEET 1 OF 1

DATE:
2-1-07

STD. NO.
508

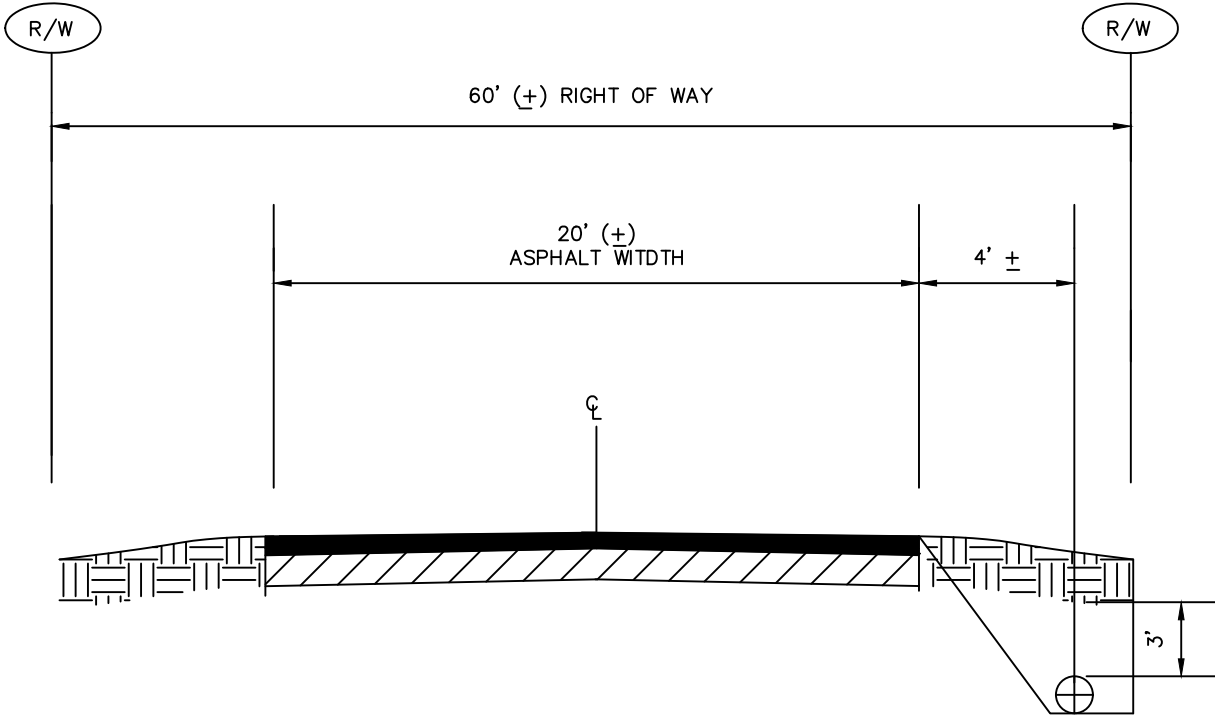

TYPICAL PAVED SECTION
NTS

- NOTES**
- BACKFILL TO BE PLACED IN 4" TO 6" LAYERS WITH PNEUMATIC TAMP AND THE SHOULDERS TO BE PLACED BACK IN ORIGINAL CONDITIONS.
 - SEED AND STRAW TO BE PLACED
 - CONCRETE DRIVEWAYS ARE TO BE SMOOTH CUT AND PLACED BACK IN ORIGINAL CONDITION AT COMPLETION OF PROJECT.
 - POUR CONCRETE FOR ALL WATER LINE FITTINGS, INCLUDING PLUGS, FIRE HYDRANTS, BENDS, ETC. UNLESS OTHERWISE NOTED IN PLANS.

NOT TO SCALE



CITY OF HICKORY		SHEET 1 OF 1	
WATER LINE INSTALLATION IN ROADWAY SHOULDER		DATE: 2-1-07	STD. NO. 509

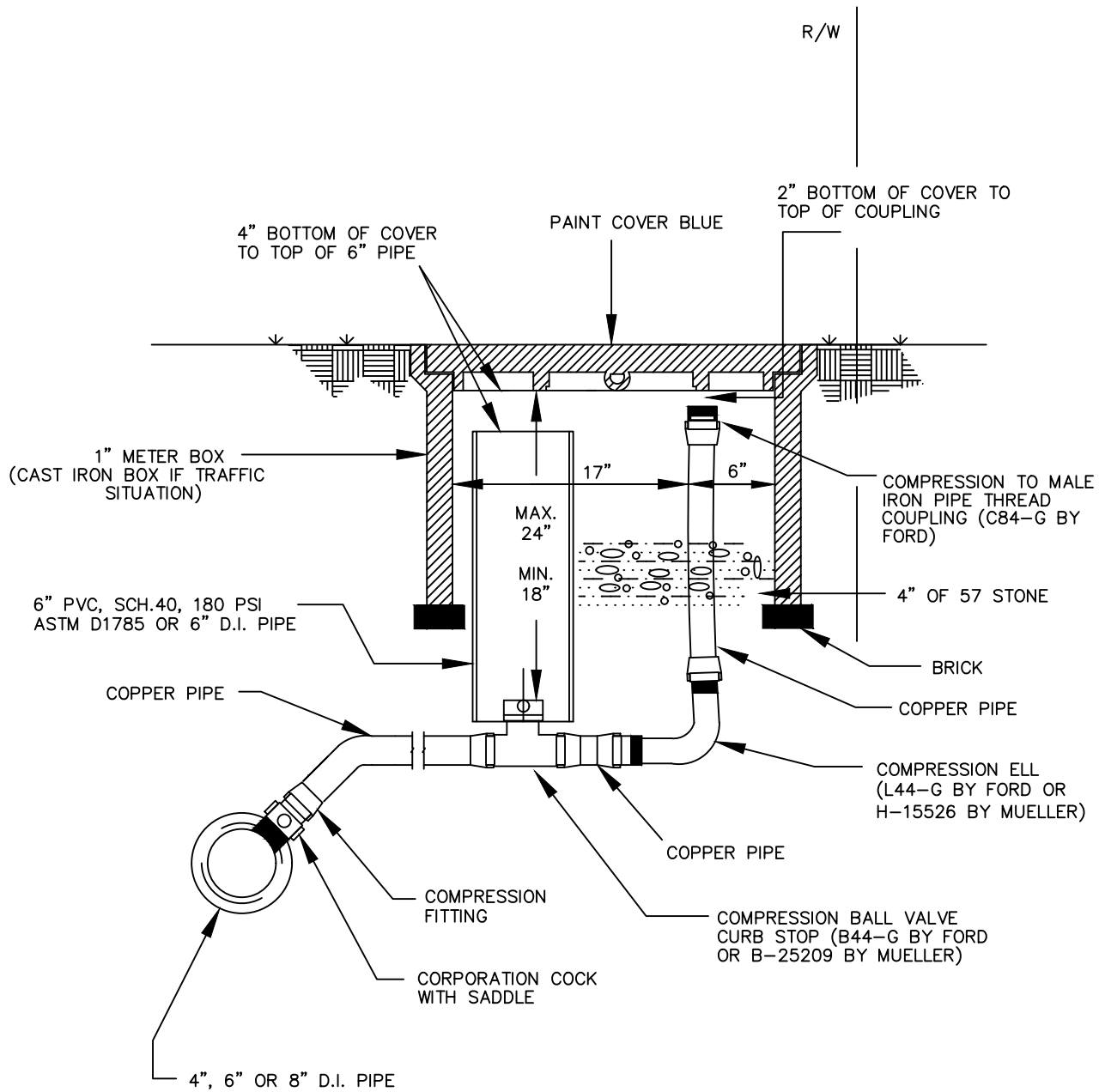

PIPE SIZE	CORP. COCK SIZE
4"	1"
6"	1 1/2"
8"	1 1/2"

NOT TO SCALE



CITY OF HICKORY

AIR BLOW-OFF ASSEMBLY

SHEET 1 OF 1

DATE:
2-1-07

STD. NO.
510

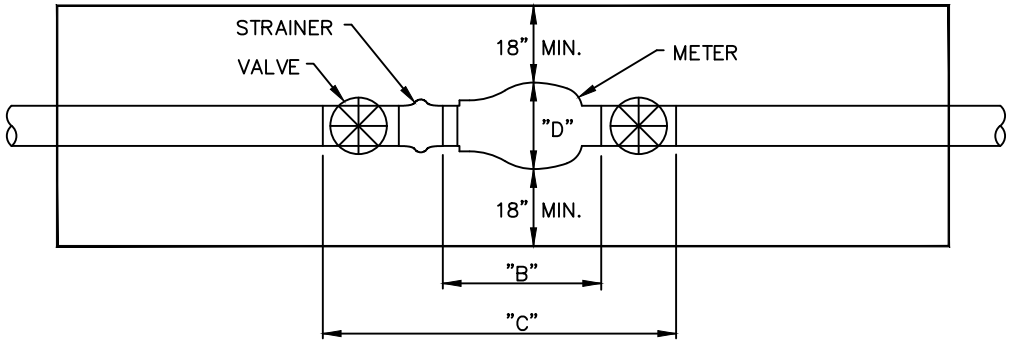

PLAN VIEW

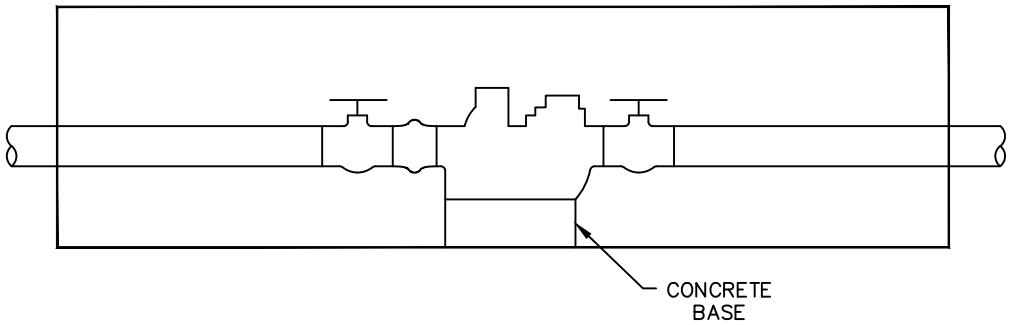

ELEVATION

DIMENSIONS

METER SIZE	"B"	"C"	"D"
3"	17"	42"	8 1/2"
4"	20"	48"	9 1/8"
6"	24"	56"	12 3/4"
8"	20"	52"	13 1/2"

* NEPTUNE METERS

HATCH ACCESS

METER SIZE	BILCO TYPE
3"	K-4 (3'x3')
4"	K-4 (3'x3')
6"	K-4 (3'x3')
8"	KD-2 (4'x4')

INTERIOR VAULT DIMENSIONS

METER SIZE	W (ft)	L (ft)	H (ft)	* PIPE OPENING
3"	4	5	3	12"x12"
4"	4	6	4	14"x14"
6"	4	6	4	14"x14"
8"	5	6	4	14"x16"

* OPENING DIMENSIONS ARE WIDTH x HEIGHT WITH OPENING CENTERED ON WIDTH OF VAULT.

NOTES:

1. CONCRETE TO BE 4000 PSI @ 28 DAY STRENGTH.
2. REINFORCING TO BE #4 BARS @ 6" CTS EACH WAY.
3. A BACKFLOW PREVENTION DEVICE IS REQUIRED AND SHALL BE THE RESPONSIBILITY OF THE OWNER/DEVELOPER. THIS SHALL BE IN A SEPERATE STRUCTURE FROM THE METER.

NOT TO SCALE



CITY OF HICKORY

METER VAULT
WITHOUT BYPASS (3"-8")

SHEET 1 OF 1

DATE:
2-1-07

STD. NO.
511

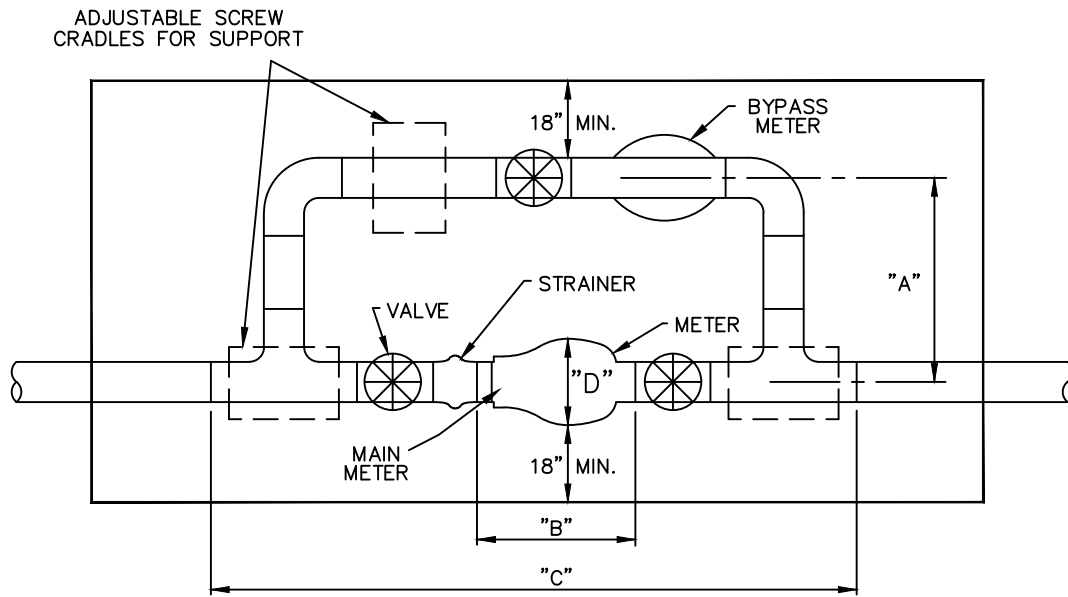

PLAN VIEW

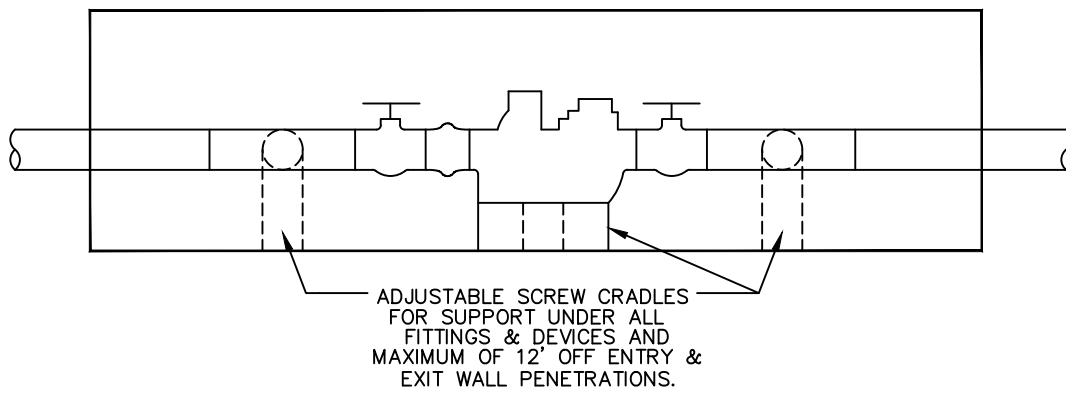

ELEVATION

NOT TO SCALE



CITY OF HICKORY

METER VAULT
WITH BYPASS (3"-12")

SHEET 1 OF 2

DATE:
2-1-07

STD. NO.
512

HATCH ACCESS

METER SIZE	BILCO TYPE
3"	K-4 (3'x3')
4"	K-4 (3'x3')
6"	KD-3 (4'x6')
8"	KD-3 (4'x6')

DIMENSIONS

METER SIZE	"A"	"B"	"C"	"D"
3"	23"	17"	53"	8 1/2"
4"	25"	20"	63 1/2"	9 1/8"
6"	28"	24"	81"	12 3/4"
8"	29"	20"	82"	13 1/2"

* NEPTUNE METERS

INTERIOR VAULT DIMENSIONS

METER SIZE	W (ft)	L (ft)	H (ft)	* PIPE OPENING
3"	5	6	3	12" x 12"
4"	5	7	4	14" x 14"
6"	6	9	4	14" x 14"
8"	6	9	4	14" x 16"

* OPENING DIMENSIONS ARE WIDTH x HEIGHT WITH OPENING CENTERED ON WIDTH OF VAULT.

NOTES:

1. CONCRETE TO BE 4000 PSI @ 28 DAY STRENGTH.
2. REINFORCING TO BE #4 BARS @ 6" CTS EACH WAY.
3. A BACKFLOW PREVENTION DEVICE IS REQUIRED AND SHALL BE THE RESPONSIBILITY OF THE OWNER/DEVELOPER. THIS SHALL BE IN A SEPERATE STRUCTURE FROM THE METER.

NOT TO SCALE



CITY OF HICKORY

METER VAULT
WITH BYPASS (3"-8")

SHEET 2 OF 2

DATE:
2-1-07

STD. NO.
512

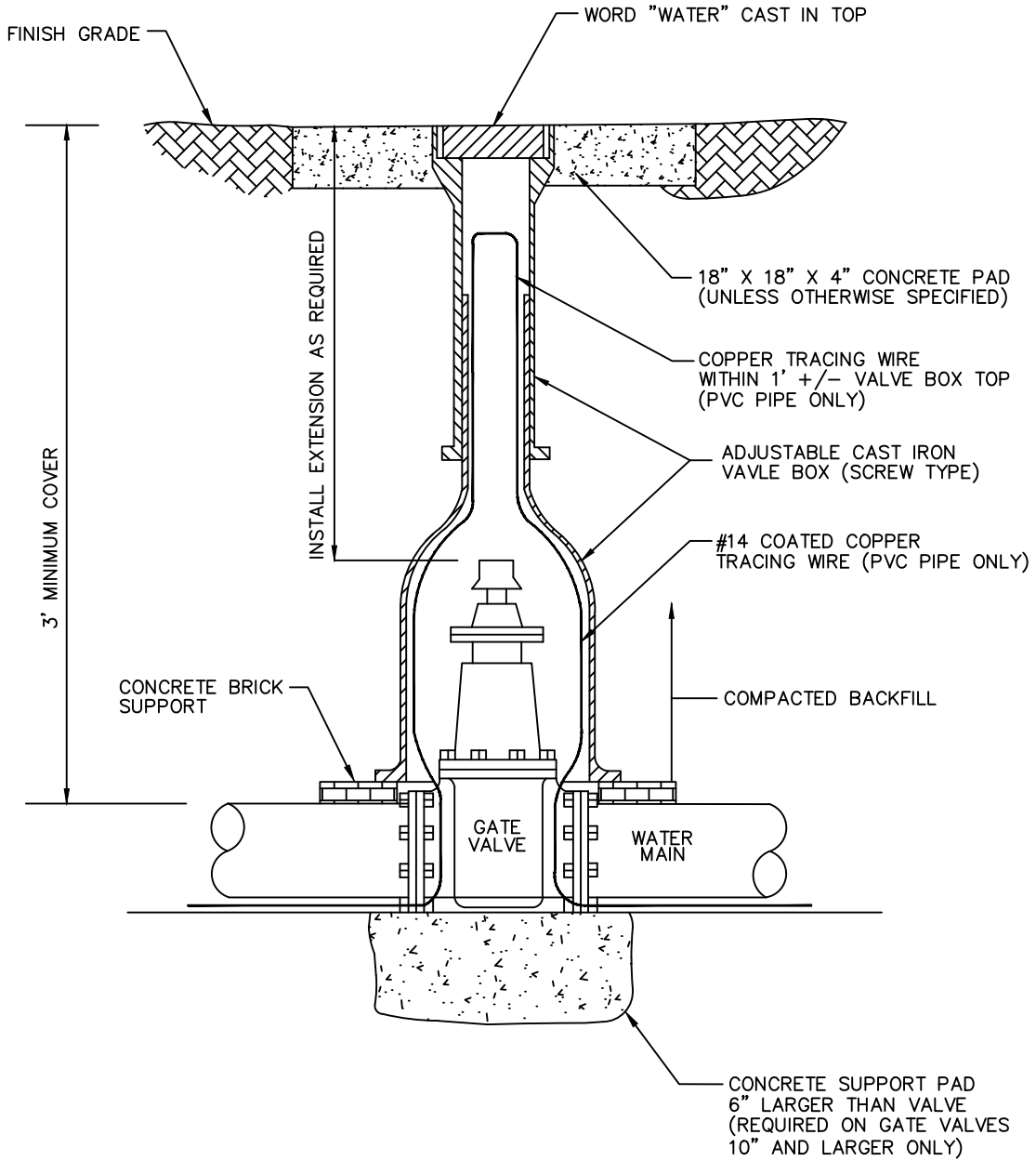

NOT TO SCALE



CITY OF HICKORY
 VERTICAL GATE VALVE
 ASSEMBLY

SHEET 1 OF 1

DATE:
 2-1-07

STD. NO.
 513

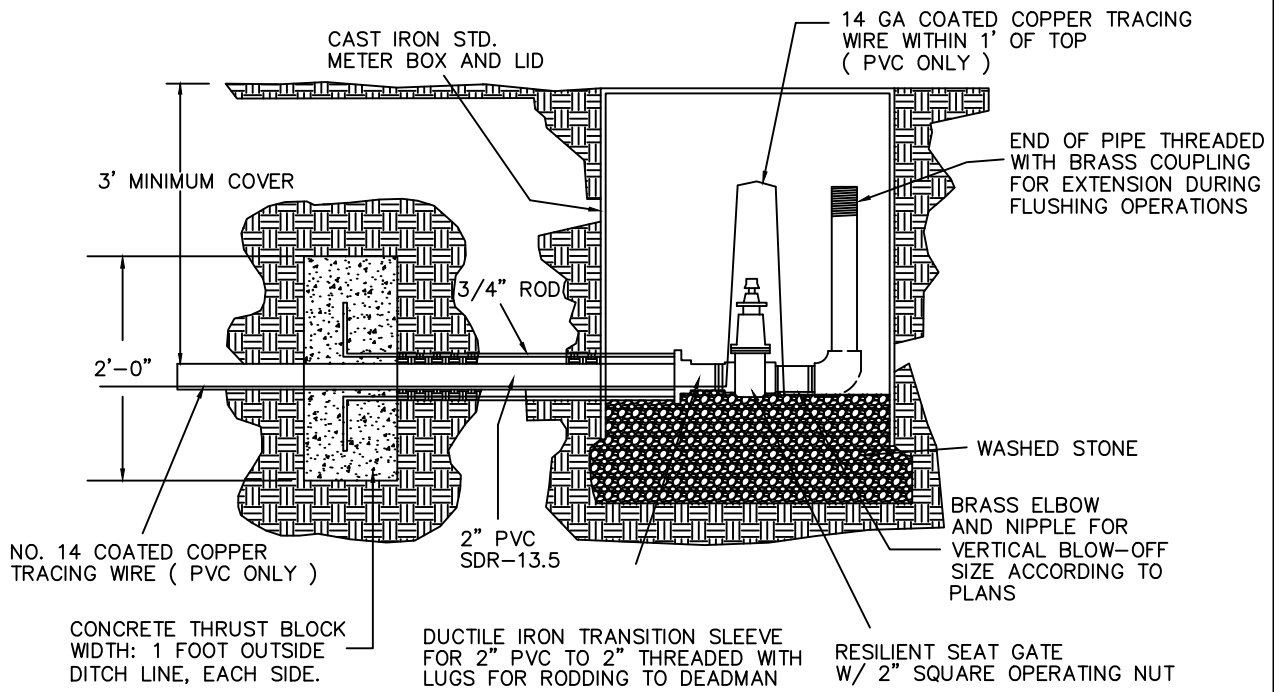

BLOW-OFF DETAIL

NOTE:
1. GLUED JOINTS WILL NOT BE PERMITTED.

NOT TO SCALE



CITY OF HICKORY
BLOW-OFF
DETAIL

SHEET 1 OF 1

DATE:
11-11-21

STD. NO.
514

CAST IRON MBX - 2 BOX

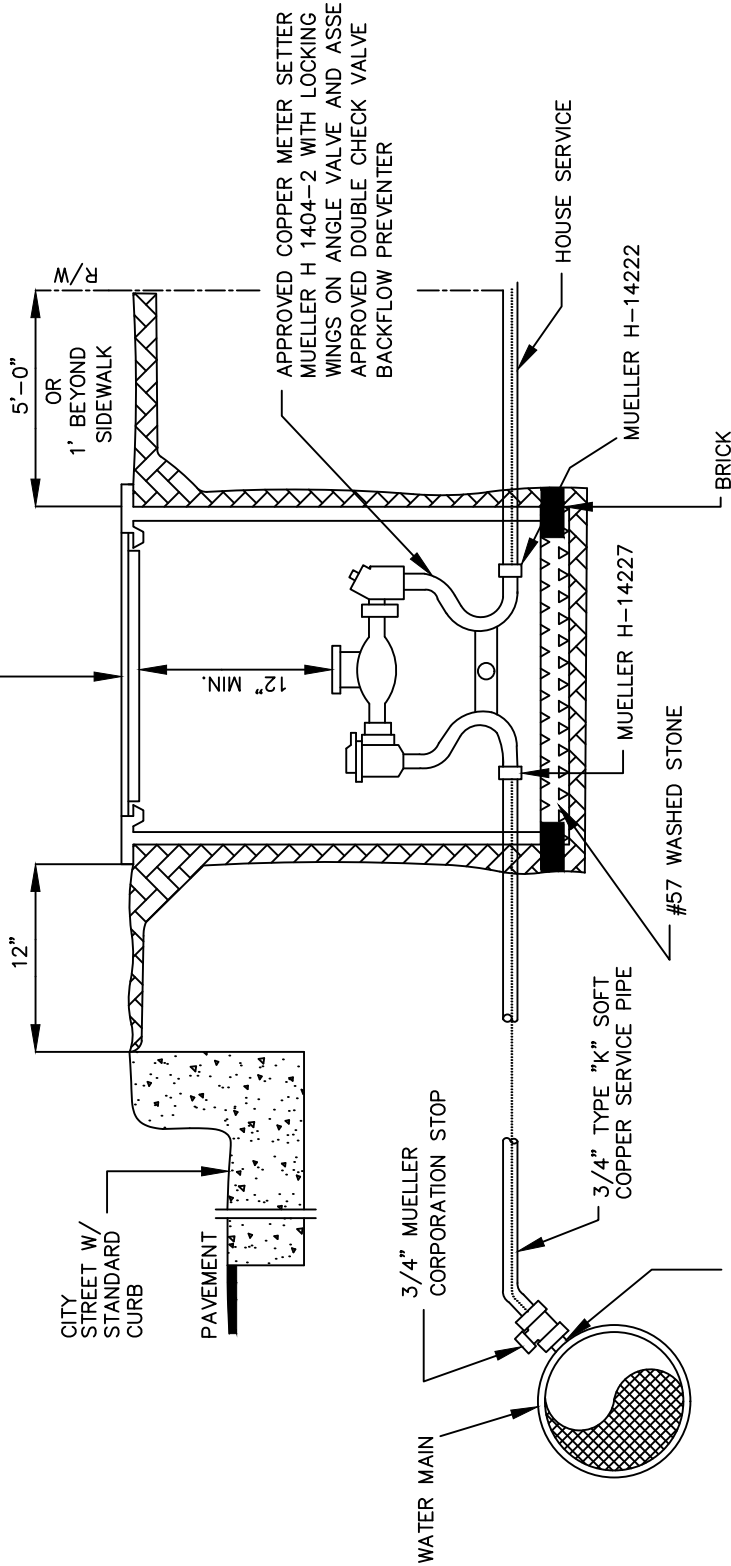

3/4" DUCTILE IRON SADDLE WITH
DOUBLE HIGH TENSION, LOW ALLOY
STEEL STRAPS, ROMAC 202 OR
SMITH BLAIR STYLE 313

3/4" CONN. SHOWN

FOR 1" CONNECTION

- 1) 1" CORPORATION COCK
- 2) 1" TYPE "K" SOFT COPPER
- 3) 1" STANDARD METER

FOR PRESSURES > 100 PSI

- MUELLER SETTERS B-2404-2AN
MUELLER CORPORATIONS B-2500-8N

NOT TO SCALE



CITY OF HICKORY

TYPICAL WATER SERVICE
CONNECTION (3/4" & 1")

DATE:
2-1-07

SHEET 1 OF 2

STD. NO.
515

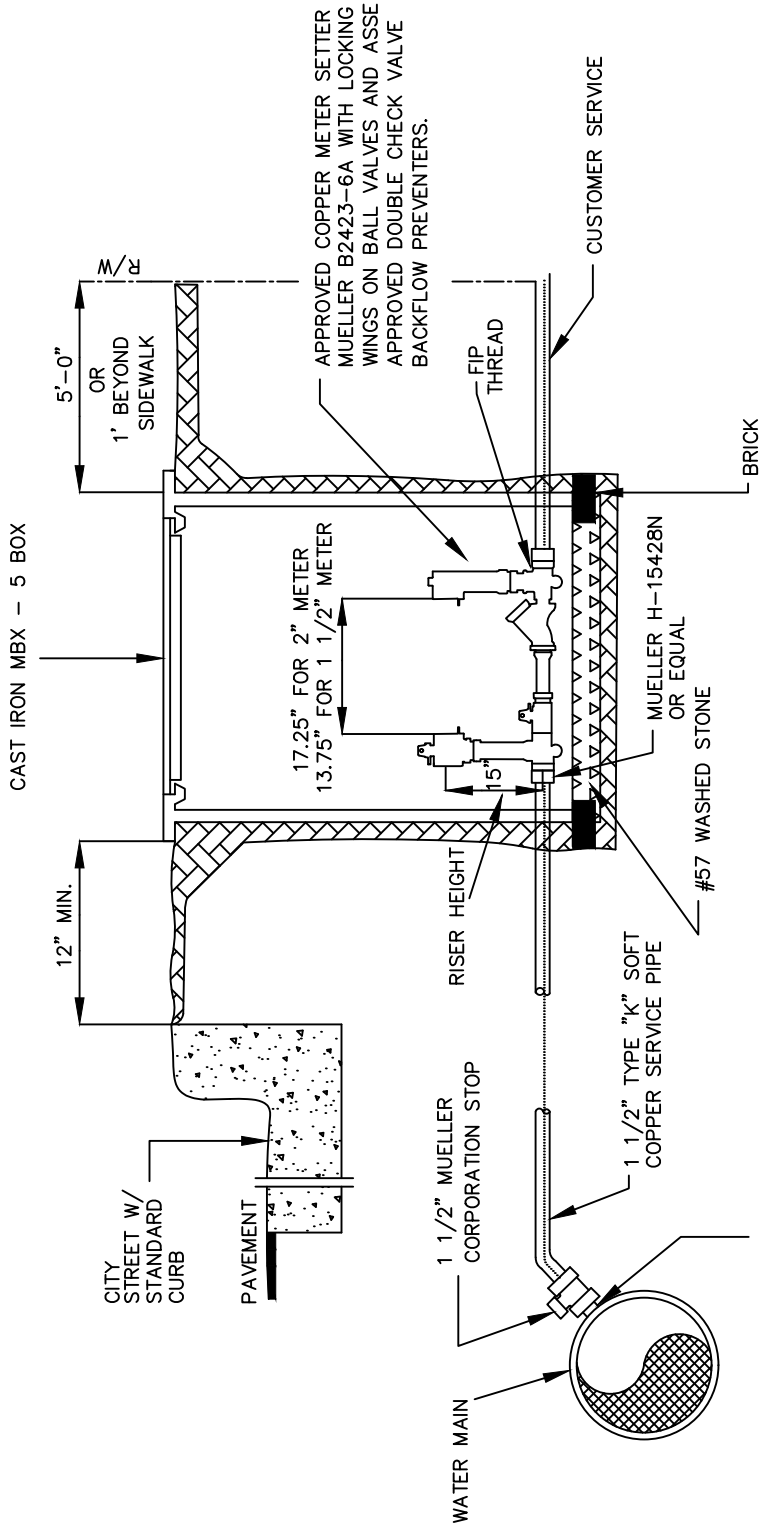

1 1/2" DUCTILE IRON SADDLE WITH DOUBLE HIGH TENSION, LOW ALLOY STEEL STRAPS, ROMAC 202 OR MUELLER BR2-B, OR EQUAL

1 1/2" CONN. SHOWN

FOR 2" CONNECTION

- 1) 2" CORPORATION COCK
- 2) 2" TYPE "K" SOFT COPPER
- 3) 2" STANDARD METER
- 4) 2" METER SETTER

FOR PRESSURES ≥ 100 PSI

- MUELLER SETTERS B-2423-6AN
- MUELLER CORPORATIONS B-2500-8N

NOT TO SCALE



CITY OF HICKORY

TYPICAL WATER SERVICE CONNECTION (1 1/2" & 2")

SHEET 2 OF 2

DATE:
10-16-18

STD. NO.
515

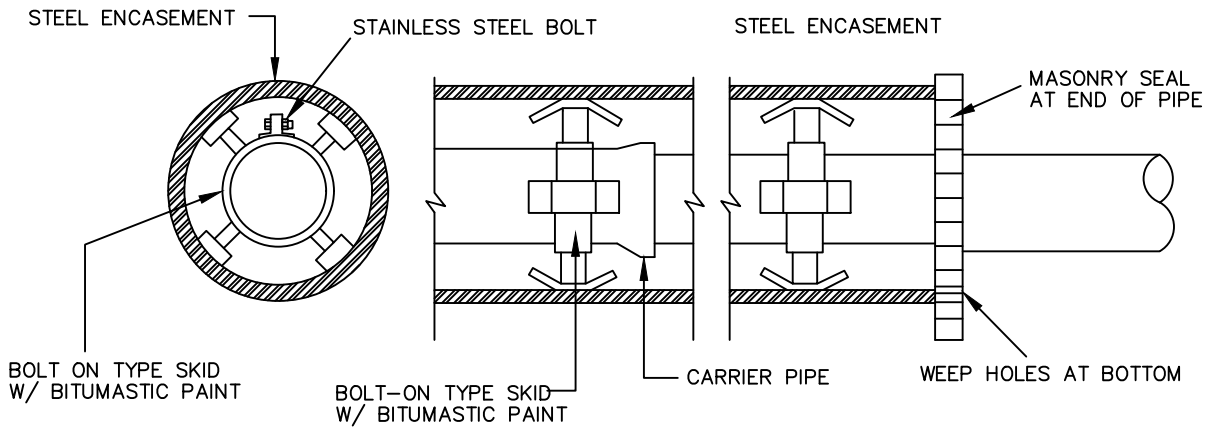
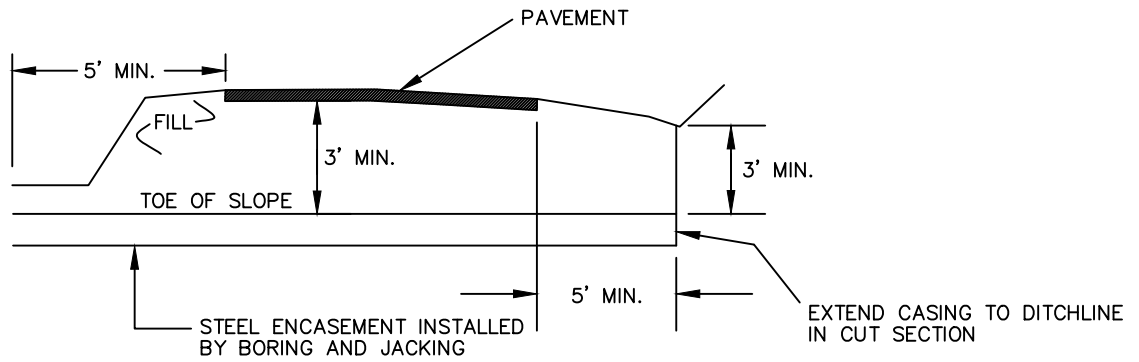

BORE ENCASEMENT DETAIL

NOT TO SCALE



CITY OF HICKORY

BORE ENCASEMENT
DETAIL

SHEET 1 OF 1

DATE:
2-1-07

STD. NO.
516

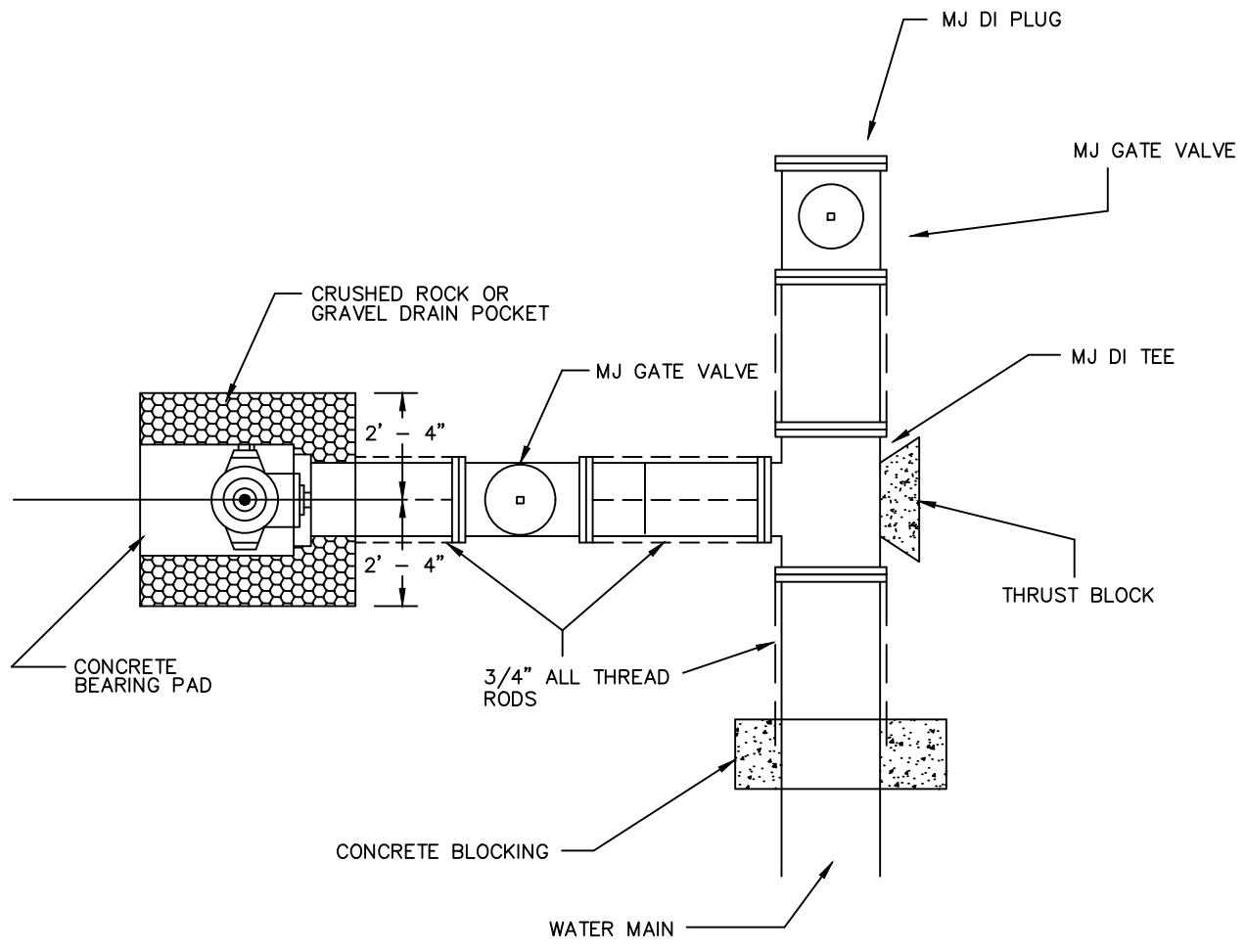
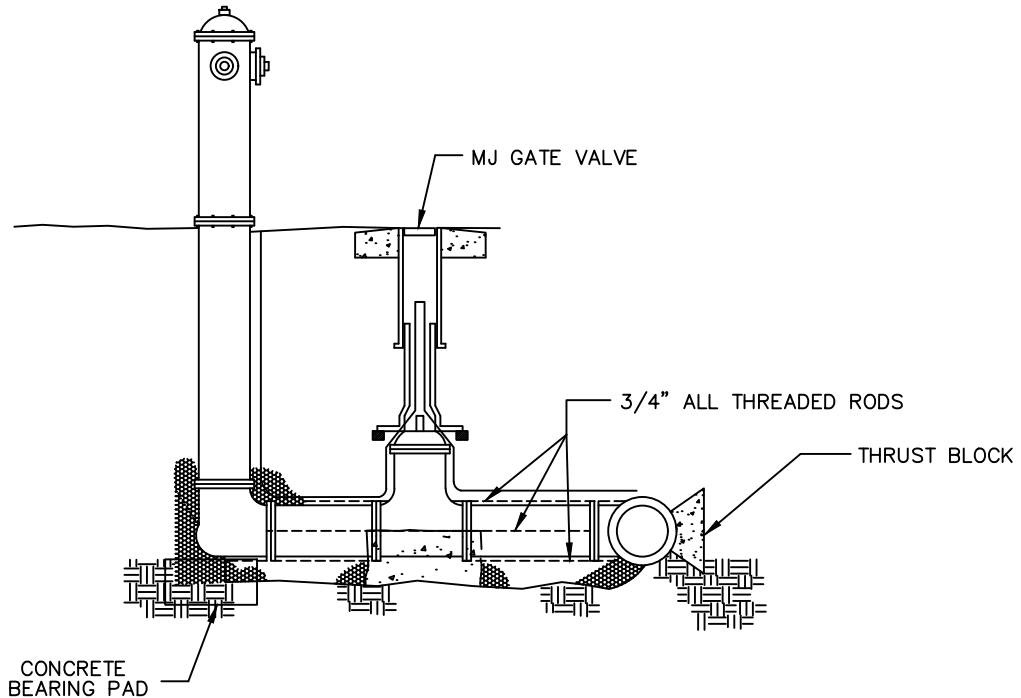

NOT TO SCALE



CITY OF HICKORY		SHEET 1 OF 1	
TYPICAL DEAD END WITH FIRE HYDRANT		DATE: 2-1-07	STD. NO. 517

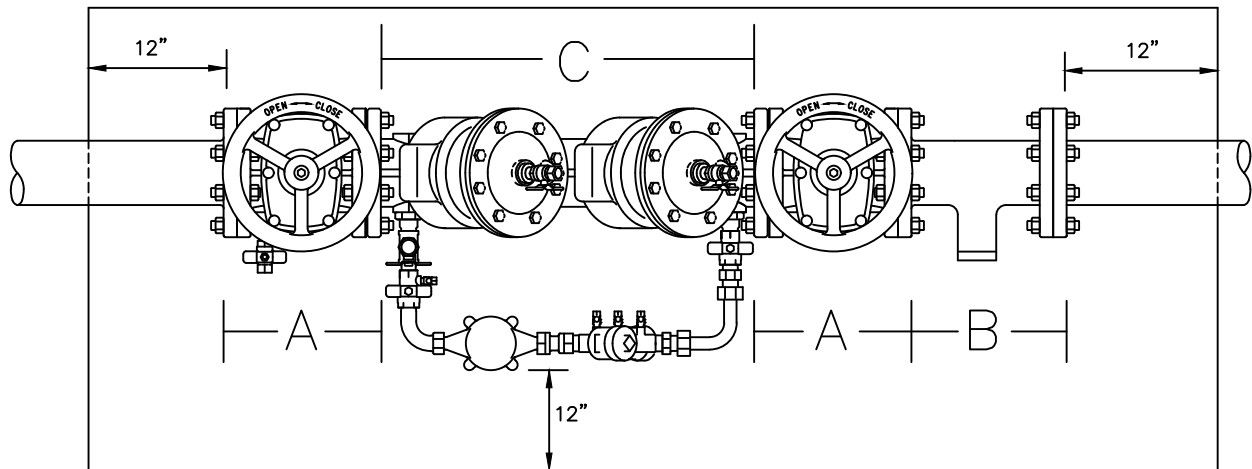
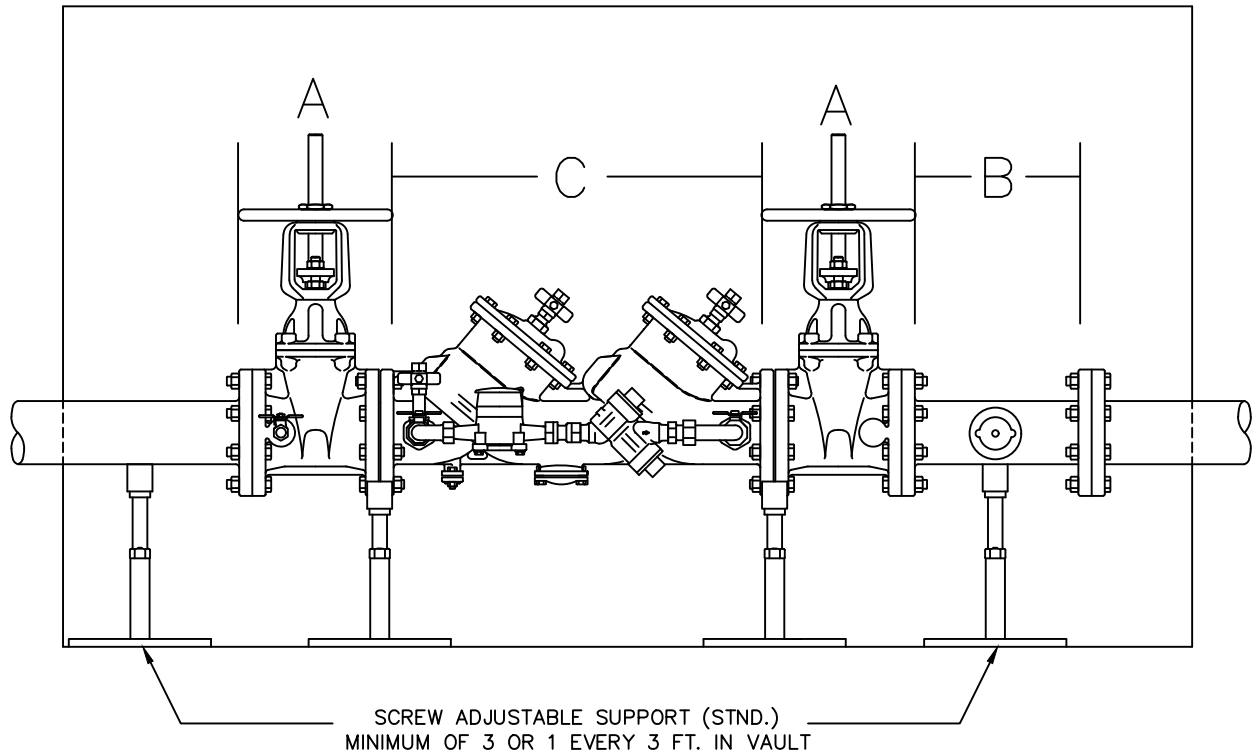

- A. GATE VALVE (NRS WHEEL OPERATED)
- B. TEE FOR FIRE DEPARTMENT CONNECTION
- C. DDCV WATER METER (FT3) ; USC APPROVED

NOT TO SCALE



CITY OF HICKORY
FIRE SPRINKLER
BACKFLOW PREVENTION

DATE:
2-1-07

SHEET 1 OF 2
STD. NO.
518

DOUBLE DETECTOR CHECK VALVE WITH METER VAULT DIMENSIONS

SIZE	LENGTH (FT)	WIDTH (FT)	HEIGHT (FT)	HATCH
2"	6	4	4	2 x 2
2 1/2"	8	4	4	2 x 2
3"	8	4	4	2 x 2
4"	10	4	4	2.5 x 4
6"	12	4	4	2.5 x 4
8"	12	4	4	2.5 x 4
10"	12	4	4	2.5 x 4

REDUCED PRESSURE ZONE ASSEMBLY VAULT DIMENSIONS

SIZE	LENGTH (FT)	WIDTH (FT)	HEIGHT (FT)	HATCH
2"	8	4	4	2 x 2
2 1/2"	8	4	4	2 x 2
3"	8	4	4	2 x 2
4"	10	4	4	2.5 x 4
6"	10	4	4	2.5 x 4
8"	12	4	4	2.5 x 4
10"	13	4	4	2.5 x 4

NOTES:

1. DOUBLE DETECTOR CHECK VALVE TO BE USC APPROVED FEBCO MODEL 856, AMES MODEL 3000 SS WITH DETECTOR OR EQUAL.
2. REDUCED PRESSURE ZONE APPLICATION TO COMPLY WITH NCDENER GREEN BOOK.
3. REDUCED PRESSURE ZONES USC APPROVED FEBCO MODEL 826 YD OR APPROVED EQUAL. VAULT AS PRODUCED BY PRECAST OR EQUAL.

NOT TO SCALE



CITY OF HICKORY
FIRE SPRINKLER
BACKFLOW PREVENTION

SHEET 2 OF 2
DATE:
2-1-07
STD. NO.
518

4" ASPHALT SURFACE COARSE
TYPE S 9.5 B

12" COMPACTED AGGREGATE
BASE COARSE

EXISTING

1.0'

COMPACTED FILL

NOT TO SCALE



CITY OF HICKORY

ROAD PATCH AND REPAIR

SHEET 1 OF 1

DATE:
2-1-07

STD. NO.
519

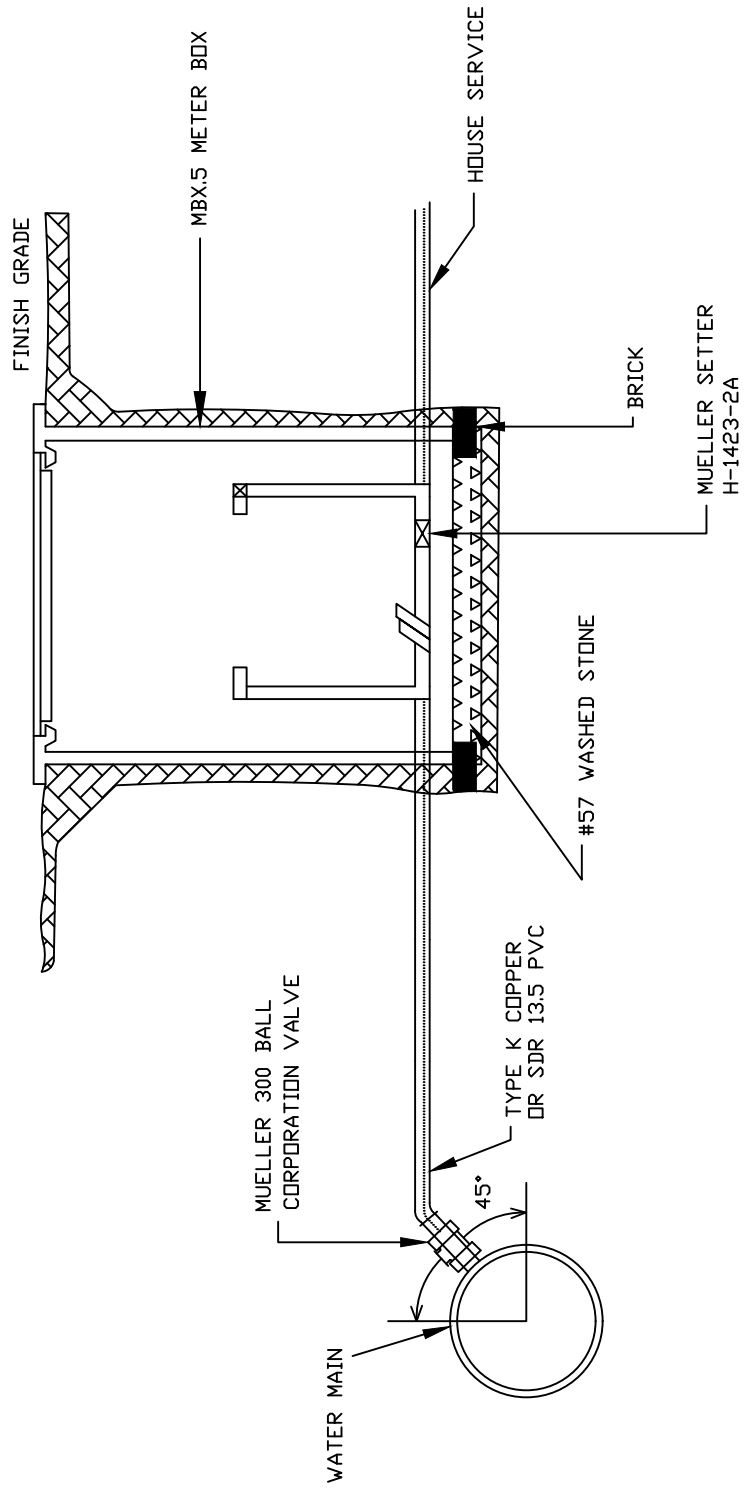

TAPPING SADDLE TO BE SMITH BLAIR
 DOUBLE STRAP TYPE OR MUELLER
 DOUBLE STRAP TYPE

NOT TO SCALE



CITY OF HICKORY

1 1/2" - 2" STANDARD WATER SERVICE CONNECTION

SHEET 1 OF 1

DATE:
2-1-07

STD. NO.
520

Engineering Department
Manual Of
Practice



Life. Well Crafted.

Water Specifications

SECTION 022000 - EARTHWORK

PART 1 – GENERAL

1.01 SECTION INCLUDES

- A. Installation, protection and/or modification of utilities during site work construction, including any necessary staging of work.
- B. Scarifying, compaction and testing of previously graded sites to ensure proper preparation and acceptability.
- C. Excavation and embankment placement to required lines, dimensions, and subgrade elevations.
- D. Preparation of existing low areas for placing of fill, including disposal of muck, topsoil, silt and wet or unsuitable materials.
- E. SUB-SURFACE DATA:
 - 1. Investigation: Sub-surface investigations tilted Geotechnical Investigation proposed Hickory Center, Hickory, NC Project No. 90G-010100.6, dated September 18, 1990 have been made. A copy of this report can be found at the back of this specification. The report is furnished as a mater of convenience and courtesy and there is no implied or expressed warranty as to the correctness of the report as to the existing condition. However, where a treatment is not covered in the specification, the recommendations made in the report shall be considered binding.
 - 2. Site Visit: Data shown is for general information for bidders. Contractors are expected to examine the site, make investigations and decide for themselves the character of the materials to be encountered.
 - 3. Responsibility: The owner will not assume responsibility for variations of sub-soil quality or condition.

1.02 REFERENCE STANDARDS

The following most current publications form part of this specification to the extent indicated by references thereto and shall be followed for all construction testing.

Section 02200-1

American Society for Testing and Materials (ASTM):

- D 422 Method for Partial Size Analysis of Soils
- D 698 Test for Moisture-Density Relations of Soils using 5.5 lb. (2.5 kg) Rammer and 12-inch (304.8mm) Drop (Standard Proctor)
- D 1556 Test for Density of Soil in Place by Sand Cone Method
- D 1557 Test for Moisture-Density Relations Using 10-lb (4.5 kg) Rammer and 18-inch (457mm) Drop (Modified Proctor)
- D 1559 Test Method for Resistance to Plastic Flow of Bituminous Mixtures Using Marshall Apparatus
- D 2167 Test for Density of Soil in Place by the Rubber Balloon Method
- D 2216 Laboratory Determination of Moisture Content of Soil
- D 2487 Classification of Soils for Engineering Purposes
- D 2922 Tests for Density of Soil and Soil-Aggregate in Place by Nuclear Methods (Shallow Depth)
- D 3017 Test for Moisture Content of Soil and Soil-Aggregates by Nuclear Methods (Shallow Depth)
- D 4318 Test for Plastic Limit, Liquid Limit & Plasticity Index of Soils
- C 25 Chemical Analysis of Limestone, Quicklime and Hydrated Lime
- C 110 Physical Testing of Quicklime and Hydrated Lime, Wet Sieve Method
- C 618 Specification for Fly Ash and Raw or Calcined Natural Pozzolan for Use as a Mineral Admixture in Portland cement Concrete
- C 977 Quicklime and Hydrated Lime for Soil Stabilization

American Association of State Highway and Transportation Officials (AASHTO)

- T 88 Mechanical Analysis of Soils

PART 2 PRODUCTS

2.01 MATERIALS

- A. Acceptable Stabilization Fabrics and Geogride:
 - 1. Mirafi 500X or 600X
 - 2. Phillips 66 Supac 6WS
 - 3. Dupont Typar 3401 and 3601
 - 4. Trevira S1114 and S1120
 - 5. Tensar SS-1 and SS-2
 - 6. Exxon GTF-200 or 350

- B. Filter/Drainage Fabrics:
 - 1. Mirafi 140NS
 - 2. Phillips 66 Supac 4NP
 - 3. Dupont Typar 3341

Section 02200-2

- C. Silt Fencing Fabrics:
 - 1. Phillips 66 Supac 5 NP (UV)
 - 2. Mirafi 100X
- D. Material for filling and backfilling shall be clean subsoil free from debris, roots, topsoil, frozen material and rock larger than ½ cu. ft. Fill materials shall be tested and approved by the laboratory for the degree of compaction required by its intended use.
- E. Unsuitable fill material shall be defined as that which fails to conform to requirements of paragraph 2.01 above.

PART 3 EXECUTION

3.01 PREPATATION

- A. Remove excess or unsuitable materials from the site at no additional cost to Owner. All excess and/or unsuitable material shall be wasted off site at allocation approved by the North Carolina Department of Natural Resources and Community Development (Erosion Control). Backfill areas with layers of material and compact as specified.
- B. Prior to placing fill in low areas, such as previously existing creeks, ponds or lakes perform following procedures:
 - 1. Drain water out by gravity with ditch having flow line lower than lowest elevation in low area. If drainage cannot be performed by gravity ditch, use adequate pump to obtain same results.
 - 2. After drainage of low area is complete, remove muck, mud, debris, and other unsuitable material by using acceptable equipment and methods that will keep natural underlying low areas dry and undisturbed.
 - 3. If proposed for fill, all muck, mud and other materials removed from above in low areas shall be dried on-site by spreading in thin layers for observation by Owner's representative. Material shall be inspected and, if found to be suitable for use as fill material shall be incorporated into lowest elevation of site filling operation, but not under or within 10'-0" of perimeter of building pad or paving subgrade. If, after observation by Owner's representative, material if found to be unsuitable material shall be removed from site at no additional cost to Owner.

4. Provide additional materials at no additional cost to Owner where existing materials are insufficient or unsuitable for their intended use. Borrow pits shall be approved by Owner's representative and the North Carolina Department of Natural Resources and Community Development (Erosion Control).

3.02 EXCAVATION FOR FILLING AND GRADING

- A. Classification of Excavation: Contractor by submitting bid acknowledges that he has investigated site to determine type, quality, quantity and character of excavation work to be performed. All excavation shall be considered unclassified excavation.
- B. Perform excavation using capable, well-maintained equipment and methods acceptable to Owner and governing agencies.
- C. When performing grading operations during periods of wet weather, provide adequate drainage and ground water management to control moisture of soils. Site dewatering is Earthwork Contractors responsibility at no additional cost to Owner.
- D. Shore, base and drain excavations as necessary to maintain safe, secure and free of water at all times.
- E. Perform rock excavation in a manner that will produce material of such size as to permit it being placed in embankments. Remove loose or shattered rock, overhanging ledges and boulders, which might dislodge.
- F. Use suitable material to replace rock overblast in building area and in expansion area to facilitate placement of utilities and future footings.
- G. Break or crush rock obtained from blasting to allow use for fill in parking area as follows:
 1. Rock 6" or greater in largest dimension is unacceptable as fill within proposed building and paving area.
 2. Rock less than 6" in largest dimension is acceptable as fill to within 24" of surface of proposed subgrade when mixed with suitable material.
 3. Rock fragments less than 2" in largest dimension and mixed with suitable material is acceptable as fill within the upper two feet (2') of proposed subgrade.

3.03 USE OF EXPLOSIVES

- A. Comply with all laws, rules and regulations of federal, state and local authorities and insure which govern storage, use, manufacture, sale, handling, transportation, licensing, or other disposition of explosives. Take special precautions for proper use of explosives to prevent harm to human life and damage to surface structures, all utility lines or other subsurface structures. Do not conduct blasting operations until persons in vicinity have had ample notice and have reached positions of safety.
- B. Contractor shall save harmless Owner, Architect and Owner's representative from any claim growing out of use of such explosives. Removal of materials of any nature by blasting shall be done in such manner and such time as to avoid damage affecting integrity of design and to avoid damage to any new or existing structure included in or adjacent to work. It shall be Contractors' responsibility to determine method of operation to ensure desired results and integrity of completed work.

3.04 FILLING AND SUBGRADE PREPARATION

A. BUILDING SUBGRADE AREAS:

1. Building subgrade pad shall be that portion of site directly beneath and ten feet (10') beyond the building and appurtenance limits.
2. The building subgrade pad shall be prepared in strict accordance with the "foundation subsurface preparation", to be provided by Owner.
3. Unless specifically indicated otherwise on the drawings, areas exposed by excavation or stripping and on which building subgrade preparations are to be performed shall be scarified to a minimum depth of 12" and compacted to a minimum of 98% of the optimum density, in accordance with ASTM D 698, at a moisture content of not less than 1% below and not more than 3% above the optimum moisture content.

These areas shall then be proof rolled to detect any areas of insufficient compaction. Proof rolling shall be accomplished by making a minimum of two (2) complete passes with a fully-loaded tandem-axle dump truck or approved equivalent, in each of the two perpendicular directions under the supervision and direction of a field geotechnical engineer. Areas of failure shall be excavated and replaced with suitable fill material per these specifications.

4. Unless specifically indicated otherwise on the drawing, fill materials used in preparation of building subgrade shall be placed in lifts or layers not to exceed 8" loose measure and compacted to a minimum density of 98% of optimum density, in accordance with ASTM D 698, at a moisture content of not less than 1% below and not more than 3% above the optimum moisture content. Unless specifically stated otherwise in the "foundation subsurface preparation" on the drawing.
5. The top 18" of building and parking subgrade shall be compacted to 100% Standard Proctor.

The following table stipulated maximum allowable values for Plasticity Index (PI) and Liquid Limit (LL) of suitable materials to be used as fill in the specified areas.

<u>Location:</u>	<u>PI</u>	<u>LL</u>
Building area, below upper four feet	20	50
Building area, upper four feet	12	40

B. SETTLEMENT MONITORING OF BUILDING SUBGRADE AREAS:

1. Settlement hubs are to be installed in the building areas in locations shown on the plans by the site grading contractor.
2. Settlement hubs shall be 8" in diameter and embedded a minimum of 30" into the subgrade at the building pad "blue top" elevation as detailed on the plans.
3. Settlement hub monitoring shall begin as soon as the building subgrade is reached. Monitoring shall be performed daily the first week of installation and weekly thereafter. Accuracy of monitoring is to be to 1/100 of a foot.
4. The on-site soils engineer shall monitor the settlement hubs. The site contractor shall insure that a stable bench mark is maintained at all times during monitoring and site work.
5. Reports of settlement monitoring and progress shall be submitted to the architect, and the general contractor.
6. Refer to soils report for further information.

7. After on-site soils engineer has determined when settlement has reached the acceptance limit, the site grading contractor is responsible for providing building pad elevations as shown on the grading plans.

C. AREAS OF CONSTRUCTION EXCLUSIVE OF THE BUILDING SUBGRADE:

1. Unless specifically stated otherwise on the drawing, areas exposed by excavation or stripping and on which subgrade preparations are to be performed shall be scarified to minimum depth of 8” and compacted to minimum of 98% of optimum density, in accordance with ASTM D 698, at a moisture content of not less than 1% below and not more than 3% above the optimum moisture content. These areas shall then be proof rolled to detect any areas of insufficient compaction. Proof rolling shall be accomplished by making a minimum of two (2) complete passes with a fully-loaded tandem-axle dump truck or approved equivalent, in each of the two perpendicular directions under the supervision and direction of a field geotechnical engineer. Areas of failure shall be excavated and replaced with suitable material per these specifications.
2. Unless specifically stated otherwise on the drawings, fill materials used in preparation of subgrade shall be placed in lifts or layers not to exceed 8” loose measure and compacted to a minimum density of 98% of optimum density, in accordance with ASTM D 698, at a moisture content of not less than 1% below and not more than 3% above the optimum moisture content.
3. The following table stipulates maximum allowable values for Plasticity Index (PI) and Liquid Limit (LL) of suitable fill materials to be used in the specified areas, unless specifically stated otherwise on the drawings.

<u>Location*</u>	<u>PI</u>	<u>LL</u>
Area below upper two feet, exclusive of building area	20	50
Upper two feet, exclusive of building area	15	40

*References to depth are to proposed subgrade elevations.

4. Material imported from off-site shall be CBR (California Bearing Ratio) value equal to or above the pavement design subgrade CBR value indicated on the drawings.

5. The site grading contractor shall provide and install all topsoil as indicated on the drawings and in conformance with landscaping plans and specifications.

3.05 MAINTENANCE OF SUBGRADE

- A. Finish subgrades shall be verified to ensure proper elevation and conditions for construction above subgrade.
- B. Protect subgrade from excessive wheel loading during construction, including concrete trucks and dump trucks.
- C. Remove areas of finished subgrade found to be insufficient for any reason to depth necessary and replace in a manner that will comply with compaction requirements per these specifications. Surface of subgrade after compaction shall be hard, uniform, smooth, stable and true to grade and cross-section.
- D. Grading of paving areas shall be within a tolerance of up to 0.10 feet as so long as it does not adversely affect drainage and other conditions. Contractor to provide engineering and field staking necessary for verification of lines, grades and elevations.
- E. Maintain subgrade for area to be paved. Make adjustments that may be required in accordance with specifications at no additional expense to Owner.

3.06 RIP-RAP

- A. Rip-rap shall be constructed as shown on the drawings.

3.07 FINISH GRADING

- A. Grade all areas where finish grade elevations or contours are indicated on drawings, other than paved areas, including excavated areas, filling transition areas and landscaped areas. Grading areas shall be uniform and smooth, free from rock, debris or irregular surface changes. Finished subgrade surface shall not be more than 0.10 feet above or below established finished subgrade elevation and all ground surfaces shall vary uniformly below indicated elevations. Finish ditches shall be graded to allow for proper drainage without ponding and in a manner than will minimize erosion potential. For topsoil application, refer to Section 02900 (LANDSCAPING, SEEDING AND SODDING).

- B. Correct all settlement and eroded areas within one year after date of substantial completion of all work at no additional expense to Owner. Bring grades to proper elevation.

3.08 FIELD QUALITY CONTROL

- A. Independent Testing Laboratory selected and paid by Owner, shall be retained to perform construction testing and act as the Owner's representative on site based on the following:
 - 1. Building Subgrade Areas, including 10'-0" Outside Exterior Building Lines: In cut areas, not less than one compaction test for every 2,500 square feet. In fill areas, same rate of testing for each lift (measured loose).
 - 2. Areas of construction exclusive of Building Subgrade: In cut areas, not less than one compaction test for every 10,000 square feet. In fill areas, same rate of testing for each lift (measured loose).
- B. In compaction requirements are not complied with at any time during construction process, remove and recompact deficient areas until proper compaction is obtained at no additional expense to Owner.
- C. In all areas to receive pavement, a CBR (or LBR) test shall be performed for each type of material imported from off-site.
- D. The following test shall be performed on each type of on-site or imported soil materials used as compacted fill as part of construction testing requirements.
 - 1. Moisture and Density Relationship: ASTM D 698 or ASTM D 1557.
 - 2. Mechanical Analysis: AASHTO T-88
 - 3. Plasticity Index: ASTM D 4318
- E. Field density tests for in-place materials shall be performed according to one of the following standards as part of construction testing requirements:
 - 1. Sand-Cone Method: ASTM D 1556
 - 2. Balloon Method: ASTM D 2167
 - 3. Nuclear Method: ASTM D 2922
(Method B-Direct Transmission)

- F. Independent Testing Laboratory shall prepare test reports that indicate test location, elevation data and test results. The architect and Contractor shall be provided with copies of reports within 96 hours of time test was performed. In event that any test performed fails to meet these specifications, Independent Testing Laboratory shall notify the General Contractor immediately.

The Contractor at no additional expense shall pay for all costs related to retesting due to failures to Owner. We reserve the right to employ an Independent Testing Laboratory and to direct any testing that is deemed necessary. Contractor shall provide free access to site for testing activities.

END OF SECTION

Section 02200-10

SECTION 02222 - EXCAVATION, BACKFILLING AND COMPACTING FOR UTILITIES

PART 1 – GENERAL

1.01 SUMMARY

This section includes the excavation, bedding and backfilling of utilities necessary to perform work indicated on drawings and contract documents.

1.02 RELATED REQUIREMENTS

Construction drawings
Specs. Section 02110 SITE PREPARATION
Specs. Section 02200 EARTHWORK

1.03 SUBMITTALS

- A. Shop drawings or details pertaining to site utilities are not required unless use of materials, methods, equipment or procedures contrary to drawings or these specifications are proposed. Do not perform work until required shop drawings have been accepted by Owner.
- B. The Contractor shall contact all utility companies and determine if additional easements will be required to complete the project. Contractor shall provide written confirmation of the status of ALL easements to the owner's Construction Manager at the time of the preconstruction conference or no later than 90 days prior to the project possession date.

PART 2 – PRODUCTS

- A. Bedding Material: Processed sand and gravel free from clay lumps, organic or other deleterious material and complying with following gradation requirements:

U.S. Sieve Size	Percent Passing (by weight)
1 inch	100
¾ inch	90-100
3/8 inch	20-55
No. 4	0-10
No.8	0-5

- B. Steel Casing Pipe: Comply with AWWA C-201 or C-202, minimum grade B, size and wall thickness as indicated on drawings.

PART 3 – EXECUTION

3.01 SUMMARY

- A. Set all lines, elevations and grades for utility and drainage system work and control system for duration of work, including careful maintenance of bench marks, property corners, monuments or other reference points.
- B. Maintain in operating condition existing utilities, active utilities and drainage systems encountered in utility installation. Repair any surface or subsurface improvement shown on drawings.
- C. Verify location, size, elevation and other pertinent data required to make connections to existing utilities and drainage systems as indicated on drawings. Contractor shall comply with local codes and regulations.

3.02 EXCAVATION, TRENCHING AND BACKFILLING

- A. Perform excavation as indicated for specified depths. During excavation, stockpile materials suitable for backfilling in orderly manner far enough from bank of trench to avoid overloading, slides or cave-ins.
- B. Remove excavated materials not required or not suitable for backfilling or embankments and waste off-site. Any structures discovered during excavation(s) shall be disposed of as specified.
- C. Prevent surface water from flowing into trenches or other excavations by temporary grading or other methods, as required. Remove accumulated water in trenches or other excavations by pumping or other acceptable methods.
- D. Open cut excavation with trenching machine or backhoe. Where machines other than ladder or wheel-type trenching machines are used, do not use clods for backfill. Dispose of unsuitable material and provide other suitable material at no additional cost to owner.
- E. All excavation shall be unclassified.

3.03 TRENCH EXCAVATION

- A. The local utility companies shall be contacted before excavation shall begin. Dig trench at proper width and depth for laying pipe, conduit or cable. Cut trench banks as nearly vertical as practical and remove stones as necessary to avoid point-bearing. Overexcavate rock, wet or unstable soil, if encountered, from trench bottom as necessary to provide suitable base for continuous and uniform bedding as directed by soils engineer.
- B. All trench excavation side walls greater than 5 feet in depth shall be sloped, shoring, sheeted, braced or other wise supported by means of the sufficient strength to protect the workmen within them in accordance with the applicable rules and regulations established for construction by the Department of Labor, Occupational Safety and Health Administration (OSHA), and by local ordinances. Lateral travel distance to an exit ladder or steps shall not be greater than 25 feet in trenches 4 feet or deeper.
- C. Accurately grade trench bottom to provide uniform bearing and support for each section of pipe on bedding material at every point along entire length, except where necessary to excavate for bell holes, proper sealing of pipe joint, or other required connections. Dig bell holes and depressions for joints after trench bottom has been graded. Dig no deeper, longer or wider than needed to make joint connection properly.
- D. Trench width requirements below the top of the pipe shall not be less than 12" not more than 18" wider than outside surface of any pipe or conduit that is to be installed to designated elevations and grades. All other trench width requirements for pipe, conduit or cable shall be at least practical width that will allow for proper compaction of trench backfill.
- E. Trench depth requirements measured from finished grade or paved surface shall meet the following requirements or applicable codes and ordinances.
 - 1. WATER MAINS: 36" to top of pipe barrel
 - 2. SANITARY SEWER: Elevations and grades as indicated on drawings.
 - 3. STORM SEWER: Depths, elevations and grades as shown on drawings.
 - 4. ELECTRICAL CONDUITS: 24" minimum to top of conduit or as required by NEC 300-5, NEC 710-36 codes or the local utility company requirements, whichever is deeper.
 - 5. TV CONDUITS: 18" minimum to top of conduit or as required by the local utility company, whichever is deeper.
 - 6. TELEPHONE CONDUITS: 18" minimum to top of conduit, or as required by the local utility company, whichever is deeper.
 - 7. GAS MAINS AND SERVICE: 30" minimum to top of pipe, or as required by the local utility company, whichever is deeper.

3.04 SHEETING AND BRACING

Provide sheeting and bracing, when necessary, in trenches and other excavations where protection of workmen required. Sheeting may be removed after sufficient backfilling to protect against damaging or injurious caving.

3.05 PIPE BEDDING

Accurately cut trenches for pipe or conduit that is installed to designed elevations and grades to line and grade from 4" below bottom of pipe and to width as specified. Place 4" of bedding material, compact in bottom of trench, and accurately shape to conform to lower portion of pipe barrel. After pipe installation, place select backfill as determined in Section 02200, and compact in maximum 8" layers measured loose to the top of the trench.

3.06 TRENCH BACKFILLING

- A. Criteria: Trenches shall not be backfilled until required test are performed and the utility systems comply with and are accepted by applicable governing authorities. Backfilling trenches as specified. If improperly backfilled, reopen to depth required to obtain proper compaction. Backfill and compact, as specified, to properly correct condition in an acceptable manner.
- B. Backfilling: After pipe or conduit has been installed, bedded and tested as specified, backfill trench or structure excavation with specified material placed in 8" maximum loose lifts. Compact to minimum density of 98% of optimum density in accordance with ASTM D 698.
- C. Compaction: Exercise proper caution when compacting immediately over top of pipes or conduits. Water jetting or flooding is not permitted as method of compaction.
- D. Compaction Testing: If determined by the owner and at the owner's expense an independent testing laboratory shall perform test at intervals not exceeding 200'-0" or trench for the first and every other eight-inch (8") lift of compacted trench backfill and furnish copies of test results as specified.

END OF SECTION

SECTION 02227 - BORING AND ENCASEMENT

PART 1 – GENERAL

1.1 GENERAL DESCRIPTION: This section covers the furnishing of all supervision, labor, equipment and materials required for the complete installation of encasement pipe and carrier pipes under highways and railroads by boring and jacking as shown on the drawings and specified herein.

1.2 GENERAL INTENTION: This section shall include construction methods for pipe lines installed by boring and jacking in the locations as shown on the contract drawings. The contractor shall inspect the locations at the proposed crossings and shall familiarize himself with the conditions under which the work will be performed, and with all necessary details and the suitability of his equipment and methods for the work required. All work in railroads shall comply with all current requirements of governing highways and railroad agencies. The Contractor shall be familiar with these requirements.

PART 2 – MATERIALS

2.1 The encasement pipe shall be of the size as shown on the contract drawings. All encasement pipe shall be smooth wall welded steel conforming to ASTM Designation A139, Grade B. The outside of the pipe shall be coated in accordance with AWWA Standard C203. Minimum pipe wall thickness shall be as follows:

Pipe-Nominal Diameter Inches	Wall Thickness Inches
16	.250
20	.250
24	.250
30	.312
36	.500

2.2 Steel spiders shall be galvanized.

PART 3 – EXECUTION

3.1 Encasements shall be installed by boring and jacking unless field conditions require otherwise. It shall be the Contractor's responsibility to notify the Engineer immediately if conditions do not permit a jack and bore installation.

- 3.2 Installation of encasement pipe shall include all related work and services such as mobilization of equipment, construction and maintaining working pits, right-of-way maintenance and restoration, traffic maintenance, mining, excavations, dewatering, sheeting, shoring and bracing for embankments, operating pits, and as elsewhere required shall be placed and maintained in order that work may proceed safely and expeditiously.
- 3.3 The encasement pipe shall be of the diameter indicated for the carrier pipe as shown on the drawings.
- 3.4 Boring Machine Alignment: The boring machine shall be accurately aligned before the boring is commenced and the Contractor shall take such necessary steps as are required to accurately place the encasement with respect to line and grade. Payment will not be made for a bore and encasement that is not accurate as to line and grade as determined by the Engineer.
- 3.5 Extension of Encasement Pipe: As the boring operation progresses, each new section of the encasement pipe shall be butt welded to the section previously jacked into place. The boring auger shall not be of a greater diameter than the outside diameter of encasement. The leading edge of the steel casing shall be kept as close to the auger head as possible and shall be advanced at the same rate of speed as the earth auger in order to minimize any unsupported holes in the earth. Any voids that occur are to be filled with 3:1 ratio sand to cement grout at 50 psi pressure, sand or pea gravel, as directed by the Engineer to insure that there will be no settlement. The Engineer will direct that this space be filled if the space is large enough to cause any earth settling. There will be no payment for grout work.
- 3.6 Before the pipe is installed in the casing, bolt-on meter skids painted with bitumastic paint shall be rigidly fastened to the barrel of the pipe. After completion of the casing, the Contractor shall insert the pipeline in the pre-jointed segments. No contact will be permitted between the casing and the carrier pipeline.
- 3.7 Obstructions: In the event that an obstruction is encountered during the boring operation which cannot be penetrated as determined by the Engineer, the auger is to be withdrawn and the steel pipe encasement is to be cut off, capped and completely filled with 3:1 ratio sand to cement grout at 50 psi pressure before moving to a new site. Payment will be made by the Owner on completed before the boring operation was stopped plus the additional linear footage at the new site. There will be no payment for the grout work.

- 3.8 Pipeline Installation: After completion of the boring and encasement, the Contractor shall insert the pipeline in pre-jointed segments. A galvanized steel spider shall be installed behind each carrier pipe bell in the encasement pipe, as shown on the Contract Drawings. After placing and jointed the pipeline, the ends of casing pipes and tunnels shall be closed with brick masonry bulkheads.
- 3.9 Method of Measurement: Measurement will be in feet along the flow line of the encasement pipe which is installed.
- 3.10 Basis of Payment: The quantity of encasement pipe measured as provided in paragraph entitled "Method of Measurement" will be paid for at the contract unit price per linear feet.
- 3.11 Payment shall be for the total number of lineal feet of encasement pipe installed at the respective unit price bid for the item.
- 3.12 Price and payment shall constitute full compensation for furnishing all equipment, labor, tools, and materials to complete all of the work required under this section including excavation of working pits, encasement pipe, carrier pipe, dewatering, shoring, etc.

End Section

SECTION 2400 – THRUST BLOCKING

1.1 INTRODUCTION

Thrust Blocks are to be installed at all fittings which change a direction of the pipeline centerline, either in part or whole including but not solely, bends and tees, at dead end situations of the pipeline or as directed by the Engineer/Owner.

1.2 MATERIALS

Concrete used for construction of Thrust Blocking shall be a minimum of 3000-psi compressive strength determined in accordance with ASTM C39 or C42 with a maximum of 5” slump delivered from the factory. The only water to be added in the field is that which the factory held back from achieving the 5” slump at the point of mixing. Reinforcing steel shall be of grade and installed as shown on the plan details in such cases, as it is required. Sakrete or any like material shall not be permitted under any circumstance.

1.3 THRUST BLOCKING CONSTRUCTION

Thrust Blocking shall be constructed to the minimum dimensions shown on the drawings or as field directed by the Engineer. All faces shall rest against undisturbed earth with the exception of the face to which the load is to be applied. Care must be exercised so that concrete is not allowed to drop more than 4’ free undisturbed fall so that separation of aggregates is avoided and maximum benefit is achieved. All joints and faces of the appurtenances to be restrained shall be wrapped continuous with a 4 mil plastic such that the concrete does not come into direct contact with bolts, joints, flanges, gaskets etc. Diligence must be exercised so that pipe joints are not encased with concrete intended to provide thrust blocking except as specified or directed by the Engineer.

END OF SECTION

Section 2400-1

SECTION 2401 – WATER VALVES, VALVE BOXES,
AIR RELIEF VALVES AND TAPPING SLEEVE & VALVES

1.1 INTRODUCTION

This section covers the requirements for furnishing and installing the above-mentioned items and their respective appurtenances as detailed on the plans. This shall include all labor, equipment, materials and incidentals that are necessary to complete installation of subject items in accordance with the plans and specifications. All supplied materials shall be of a type and class as specified herein

This section will specify storage and handling, excavation, bedding, laying and coupling of joints and backfilling. All construction shall be as specified as herein, unless written deviation is received from the Engineer.

Work under this section shall be measured by the actual number of components and paid for at unit prices established in the Contract.

1.2 CATALOG CUT SUBMITTALS

Contractor shall submit 4 copies of catalog cuts to Engineer for review for all materials that are required to complete the work as described in the associated plans. Engineer will retain two sets of original submittals and return two sets to the Contractor with the appropriate response annotated.

1.3 STORAGE AND HANDLING

The Contractor shall inspect the materials upon receipt for visible defects prior to off loading. The Contractor shall unload all valves and appurtenances as so to avoid any deformation or other injury. The Contractor shall implement appropriate measures during storage such that no storm water may pass through or encumber the materials. All materials shall be stored in such a manner that they will drain and so protect them from contamination or freezing.

If any material is found to be defective during installation, then same material shall be removed and replaced with appropriate quality and type at the Contractors expense.

1.4 MATERIALS

A. Gate Valves:

All Gate Valves shall as a minimum reflect a rating of 200 psi, contain clearway equal to the full nominal diameter of the adjoining pipe, be open left operation (counterclockwise), reflect the name and date of manufacture, be of non-rising stem type, contain a directional arrow for operation cast into the body, have a 2” operating nut for control and contain Mechanical Joint connections. All requirements shall be met unless specified on the plans or directed by the Engineer in writing.

All materials shall withstand a hydraulic test pressure of equal to twice the rated pressure and Contractor shall provide written proof of test from manufacturer upon request.

A.1 Resilient Seated Wedge Valve:

Gate Valves 2" through 36" diameter shall be of cast iron or ductile iron body, resilient seated wedge type valves conforming to the requirements of AWWA Standard C 509 and/or AWWA Standard C 500. Unless specifically approved in writing by the Engineer all valves shall be from one manufacturer and all parts interchangeable.

Gate valves shall conform to ASTM A-536 as it relates to cast iron or ductile iron manufacturer of the body, bonnet and gate. Shell thickness of components shall conform to the thickness in Table 2, Sect. 4.4 of AWWA Standard C 509 or AWWA Standard C 500 as appropriate. Valve body and bonnet coating shall conform to AWWA Standard C 550 and include fusion bonded epoxy coating for the interior and exterior surfaces of the valve.

The gate shall be completely covered with a rubber coating securely fixed to all ferrous surfaces. The gate and rubber coating shall conform to ASTM D429.

Valve stems shall be of cast bronze construction. Valves shall contain a stuffing box, which located above the thrust collar, which will contain O-rings for sealing. The valve shall be of type construction that allows replacement of the ring seals while the valve is fully open and under pressure.

Valves 16" and larger in diameter shall be designed and constructed in such a manner as to include beveled reduction gears to reduce the number of turns and torque required to operate valves.

A.2 Double Disc Valves:

Gate valves larger than 36" diameter shall be ductile iron body, double disc parallel seat conforming to AWWA Standard C 500. All valves shall be from one manufacturer with interchangeable parts.

Gate valves shall conform with ASTM A536 as it relates to manufacturer of body, bonnet and gate constructed of ductile iron. Entire valve body and bonnet shall be coated on interior and exterior surfaces.

Gates shall be constructed of cast iron smooth and continuous without pockets on either face. Cam surfaces shall be open to the bottom. Gate ring seals shall be inserted into a dovetail groove under pressure and make up a single insertable finish.

Gate valves shall operate as a bottom wedging design with a two-part wedge contact. Wedge and Hook shall be separate castings.

Valve stems shall be of cast bronze construction. Valves shall contain a stuffing box, which located above the thrust collar, which will contain O-rings for sealing. The valve shall be of type construction that allows replacement of the ring seals while the valve is fully open and under pressure.

Valves 16" and larger in diameter shall be designed and constructed in such a manner as to include beveled reduction gears to reduce the number of turns and torque required to operate valves. All rollers, tracks and scrapers shall be of bronze casting.

Bypasses shall be supplied and installed as a part of all valves. Bypass shall be a minimum of 3" diameter and operating mechanism shall be of resilient seated wedge type.

B. Valve Boxes:

All valve boxes shall be adjustable screw type with a base sized to fit over the valve yoke and a lid with "water" cast integral. All valve boxes shall be constructed of domestic or foreign cast iron that complies with the requirements of ASTM A48. Valve boxes shall be the appropriate range of adjustment for the site and Contractor should minimize the use of extensions.

C. Air Valve:

All air valves shall operate as both an air/vacuum valve and air release valve simultaneously in one unit. The air/vacuum portion of the appurtenance shall operate such that during the filling operation, or when necessary, it will allow large amounts of air to be expelled from the line to avoid substantially compressing air in the line and also operate to effectively allow air to reenter the line in the case that internal pressures would approach negative values, such as happens with line breaks or separations. The air release portion of the valve shall operate such that it automatically releases minute amounts of air as necessary while in service. All air valves must conform to AWWA Standard C512.

All air valves shall contain a rating of 150 psi with a test rating of 300 psi.

Body and cover shall be manufactured of cast iron conforming to ASTM A126, Class B. The float shall be stainless steel with stainless steel guide and rated to withstand ultimate system surge pressure successfully. Valves 4" and larger shall have floats of stainless steel with dual stainless steel guides and rated to withstand ultimate system surge pressure successfully. The body and cover shall be constructed of cast iron and be concentrically located. All internal parts shall be stainless steel or Buna-N rubber.

D. Tapping Sleeve and Valve:

All sleeves shall have flanged outlet of appropriate size and strength to accommodate the tapping valve. Tapping valve shall be resilient seat wedge gate valve design with each flange capable of accepting the sleeve, tap machine face, or mechanical joint connection to adjacent pipe.

Tapping sleeves up to 12" shall be Stainless Steel Wrap Around type. Tapping sleeves 12" and larger shall be Ductile Iron Full Body type. All tapping sleeve and valves shall be of the size and type detailed on the plans.

Stainless steel tapping sleeves shall be constructed of two-piece stainless steel jointed by grade 18-8 stainless steel bolts. The gasket shall be girded virgin SBR compound rated for water service per ASTM D2000 and the gasket shall provide full range pipe coverage. Outlet pipe shall be constructed of grade 18-8 stainless steel and be schedule 5. All sleeves shall contain a 3/4" test outlet with brass plug for the purpose of air testing the sleeve.

All connections to the existing system shall be coordinated with the Water Purveyor having jurisdiction.

1.5 INSTALLATION

A. Excavation:

This section shall cover the excavation and proper disposal of any and all materials disturbed during the construction of trenches which is further defined as all excavation necessary for the proper installation storm or sanitary sewers and any appurtenances and waterlines and any appurtenances. This section shall further cover any work deemed appropriate by the Engineer.

Excavation shall be done to the lines and grades as depicted or detailed on the plans or as directed by the Engineer. All work involving this section shall be coordinated with any Grading, Site Utility work or other construction on the project site and shall be maintained satisfactorily so that adequate drainage is provided at all times. Any roots that protrude into the trench lines shall be trimmed flush with the trench walls.

All excavation shall be open cut unless otherwise depicted on the plans or specifically authorized by the Engineer. If after excavation the bottom of the proposed trench is found to contain rock, materials which can not be removed with standard and prudent construction equipment or is unsuitable for providing a uniform bearing surface then same material shall be removed to a depth not less than 8" below proposed depth, backfilled with approved material and compacted. Excavation widths shall be such that not less than one full diameter of the pipe is clear between the outside face of the pipe and each closest trench wall or inside face sheeting, shoring, or trench box as necessary.

Excavated materials to be used during backfill operation shall be suitable material, significantly free from debris and/or rocks and approved by the Engineer. Acceptable material which is excavated shall be neatly and compactly deposited at the sides of the trench where space provides but at no time closer than 2'0" from the closest side of the trench. When stockpiling of material is required, the Contractor at his expense shall do so at an approved site and this site shall be kept and neat to avoid unsightly appearance. Stockpiling shall be arranged to allow for natural drainage without pollution of water by erosion.

B. Sheeting, Bracing and Trench Boxes:

As appropriate reference to OSHA Regulation 1926.652(b), the Contractor will be required to keep the sides of excavation vertical by sheet, bracing or the use of trench boxes to prevent movement by slides or settling of the side, to prevent injury or displacement of pipe or appurtenance or diminished the required working space adjacent to pipe. Furthermore, the Contractor may be required, for the purpose of preventing injury to persons, property or adjacent structures, to leave sheeting or bracing in place.

All measures employed, when required, shall extend a minimum of 18" above existing grade and a maximum of 48" above grade. In no case shall timbers, beams or other sheeting/bracing materials be left in the trench, which may form or promote voids that cannot easily be corrected during the backfilling operation or compaction of backfill. It is agreed upon by these specifications that where it is necessary to leave sheeting or bracing intact and backfilled that the Owner is under no obligation to pay Contractor for time or materials involved in constructing such measures. Contractor shall assume and accept any and all risk associated with or encumbered by failure to implement proper and necessary sheeting, bracing or trench box use on any excavation and will be held responsible for caving, settlement and all other damages resulting there from.

C. Valves:

Prior to each installation, the Contractor shall make sure the interior is wiped clean and the valve is test operated by opening and closing. All valves shall be set with the operating mechanism plumb and at the location depicted on the plans.

Initial backfill shall be thoroughly compacted by hand around the valve body to a distance of 12" in all directions and compaction by mechanical means such as vibratory trench roller or striking compactor shall be thoroughly achieved to a distance of 3' 0" each side.

D. Valve Boxes:

A valve box shall be installed over every underground valve. All valve boxes shall be set plumb with the valve; the operating mechanism of the valve shall be centered in the top opening and their lid flush with finished grade.

E. Air Valves:

All air valves shall be installed in a cast iron meter box with a minimum of 18" by 24" clear inside dimension and at the exact location as depicted on the plans.

F. Tapping Sleeve and Valve:

All tapping sleeves shall be installed at the exact location as depicted on the plans. All tapping sleeves shall be installed per strict conformance with manufactures specification, flange perfectly horizontal with existing pipe and bolts tightened with a torque wrench to the proper specification. All tapping valves shall follow valve installation requirements. The tapping sleeve shall be air tested prior to performing the tap into the existing line.

1.6 BACKFILLING AND COMPACTION

A. Trenches shall be backfilled immediately upon approval of pipeline construction.

B. Roadways and Crossing:

Full depth and width of trench shall be backfilled by placing material in uniform layers not to exceed 12" thick and shall be thoroughly compacted by approved mechanical compactors under optimum moisture conditions. Compaction of the trench shall be to 95% as determined by Standard Proctor Test for all areas outside the paved area and any depth exceeding 18" below finished surface of asphalt. The top 18" of any trench directly under pavement or within 36" of the edge of pavement shall be compacted to 100% as determined by Standard Proctor Test. If existing material is not suitable for obtaining compaction then select backfill shall be used when requested by the Engineer.

All paving and base course affected shall be removed and replaced with new material of equal or better quality with like texture and color as the adjacent pavement.

All backfill methods shall be in strict compliance with manufactures recommendations and all methods shall be instituted such that no damage, misalignment, or unjointing of the pipe or appurtenances is experienced.

Backfill shall be kept free of organics (grasses, sticks, stumps, roots etc.), stones (all stones over 1" diameter within first 12" of backfill and all stones over 2.5" diameter for the remainder of the backfill), any frozen soil or other soil which is not suitable for backfill (highly plastic clay) or any other objectionable items. All backfill shall be installed and graded in a manner that erosion or saturation will not negatively affect the backfilled area.

Heavy equipment shall not be operated over any pipe or appurtenance until it has been properly backfilled and has minimum cover as required by the plans. Where any part of the required cover is above proposed finished grade, the Contractor shall place, maintain and lastly remove such material at no additional cost to the Owner. Any pipe or appurtenance, which becomes misaligned, shows excessive settlement or has been damaged by the Contractor shall be corrected or replaced as deemed necessary by the Engineer/Owner at no additional cost to the Owner.

Prior to acceptance, the Contractor shall properly maintain all installations in such a manner that they will operate without failure.

C. Finish Grading:

All areas disturbed shall be graded to a continuous finish without irregularities or abrupt changes and shall not consist of areas, which will retain water or cause foreseeable future maintenance. Prior to acceptance, all debris, excess material, trash or any unsightly occurrence shall be removed and the project site shall be in a neat and satisfactory condition.

END OF SECTION

Section 2401-7

SECTION 2402 – FIRE HYDRANTS AND APPURTENANCES

1.1 INTRODUCTION

The scope of work covered under this section shall be to furnish all labor, equipment, materials and any other items that are necessary for the proper installation of fire hydrants. Fire Hydrants shall conform to the applicable requirements of AWWA Standard C502 (Latest Edition) for dry barrel, traffic model type.

1.2 CATALOG CUT SUBMITTALS

Contractor shall submit 4 copies of catalog cuts to Engineer for review that are required to complete the work as described in the associated plans. Engineer will retain two sets of original submittals and return two sets to the Contractor with the appropriate response annotated.

1.3 STORAGE AND HANDLING

The Contractor shall inspect the materials upon receipt for visible defects prior to off loading. The Contractor shall unload all fire hydrants and valves so as to avoid any deformation or other injury. The Contractor shall implement appropriate measures during storage such that no storm water may pass through or encumber the materials. All materials shall be stored in such manner that they will drain and so protect them from contamination or freezing.

If any material is found to be defective during installation, then same material shall be removed and replaced with appropriate quality and type at the Contractors expense.

1.4 MATERIALS

A. Fire Hydrants:

All fire hydrants shall comply with all applicable standards of AWWA Standard C502 (Latest Edition) for dry barrel, traffic model type. The traffic model shall consist of a break away flange and stem which will allow the upper section of the hydrant barrel and operating stem to separate from the lower components upon impact and not cause damage to the lower section. All hydrants shall contain O-ring seal for the operating stem which prevents contact between the stem and water at all times. All hydrants shall have an automatic oiler system which introduces lubricant every time the stem is operated.

Fire hydrants shall consist of two 2½ inch hose nozzles and one 4½ inch pumper nozzle all nozzles shall be reverse thread into the barrel and the thread pattern shall be National Standard Threads as per Appendix A of AWWA Standard C502. Furthermore the operating nut shall be pentagonal shaped with 1½ inch between the point and flat. Hydrants shall be operated open left (counterclockwise) with a 4½ inch compression base seat opening against pressure. All hydrants shall be capable of operating against 250 psi working pressure and shall withstand 500 psi hydrostatic test pressures.

All hydrants shall have standard 6 inch mechanical joint connections and shall be no less than 3 foot 6 inch bury unless otherwise noted on the plans. All hydrants shall be painted the appropriate color as indicated on the plans and shall have reflective bead bonnets. Following installation and testing and before final acceptance all fire hydrants shall be painted with epoxy paint to an acceptable appearance resulting in uniform color and no oxidation or rusting.

All fire hydrant iron parts shall be fabricated of ductile iron.

The fire hydrant main valve shall be 4½ inch minimum and shall be of the full compression design, opening against and closing with pressure. The valve seat ring shall thread into a bronze sub-seat and all gaskets sealing the seat ring shall be bronze to bronze surface.

Drain valves shall be bronze and allow complete draining of all residual water in the hydrant barrel. Draining shall be automatic and not dependent on separate operation.

All bolting and fasteners shall be stainless steel.

The operating mechanism shall utilize two O-ring seals between the revolving nut and bronze sheathed upper section of the valve rod. The top of the rod shall also be fitted with a travel stop nut to limit downward travel of the rod. A thermoplastic thrust washer shall be used to reduce friction in the thrust collar while opening the hydrant. All weather grease shall be used to provide permanent lubrication.

1.5 INSTALLATION

All fire hydrants shall be connected to the main waterline with a 6 inch leg consisting of the same material as the main waterline and having at least the same depth of bury. All fire hydrants shall be installed plumb with the pumper nozzle facing parallel to the roadway and with the center of the lowest outlet not less than 18 inches or more than 24 inches above finished grade. Hydrants shall be rodded to the 6 inch gate valve and the valve rodded to the branch tee or mounted directly to a hydrant tee. Backfill around fire hydrants shall be thoroughly compacted to finished grade and not less than seven cubic feet of clean stone meeting gradation #67 shall be placed 6 inches under, around the base, and up the barrel to insure proper residual drainage from the barrel. A solid and sound cap block shall be set under the fire hydrant shoe for a solid base.

Fire hydrants shall be located, painted and buried to the depth shown on the plans.

END OF SECTION

SECTION 2500 – LEAKAGE TESTING

1.1 INTRODUCTION

All structures are required to be watertight and all pressure and gravity piping and pipelines shall be tested by the Contractor as directed by this section and/or the Engineer/Owner. All tests shall be organized by the Contractor at the Engineers convenience.

All labor, equipment, water, materials, gauges, meters and any other items shall be furnished by the Contractor at his expense. In the case of a failed test, minor defects will be corrected and retested immediately. Any failure due to a major defect will constitute stopping the test and rescheduling with Engineer/Owner.

1.2 STRUCTURES

All fluid containing structures shall be subject to a gravity pressure test by filling the structure with water to overflow, or as directed by the Engineer, and observing the water level for a period not less than 24 hours. Leakage will be considered to be within the allowable limits for structures when there is no visible sign of leakage evident by either moisture on exposed surfaces or water level drop in excess of 1 inch within the 24 hour period. All wall castings or penetrations shall be plugged temporarily during the test period.

If leakage exceeds the allowable limit, the work shall be repaired by removing and replacing the defective portions, waterproofing the inside and outside or by other methods as approved by the Engineer.

1.3 PRESSURE PIPING

All pressure piping shall be subject to a hydrostatic pressure/leakage test in accordance with AWWA C600 (Ductile) or AWWA C605 (PVC).

Upon satisfactorily constructing the pipeline, including all appurtenances called for on the associated plans, and effectively backfilling the trench the hydrostatic test shall be conducted.

The Contractor shall prepare a testing plan/schedule to be approved by the Engineer, which will effectively test the entire section to be constructed, and at no time test more than 4,000 linear feet of pipeline at one time.

As the pipeline is being filled with water in preparation of the test, all air shall be expelled from the pipe. If sufficient exit points are not available, the Contractor at his expense shall install air reliefs of a type and location as approved by the Engineer.

The pipeline shall be subjected to a hydrostatic pressure of 150 psi or 50 psi above existing line static pressures, whichever is greater, for a period of 2 hours or as specified by the Engineer. Pressure shall be applied to the line by means of hand pump for lines 2" and smaller or by approved mechanical means for larger lines

Allowable leakage shall not exceed that determined by the following formula:

$$L = \frac{SD(P)^{1/2}}{148,000}$$

- L = Allowable leakage in gallons per hour.
- S = Length of line under test in feet.
- D = Nominal diameter of pipe in inches.
- P = Average test pressure in psi.

Any visible leak shall be corrected to minimize water leakage no matter of the allowable leakage calculation.

All pipe and appurtenances found to be defective during the hydrostatic test shall be removed and/or corrected at the Contractors expense and Engineers approval.

All materials shall be subject to manufacturer's recommendations for storage, pre-testing, etc.

After a successful test has been obtained the Contractor shall notify the Engineer in writing and request written recognition from Engineer of acceptable test results.

END OF SECTION

Section 2500 - 2

SECTION 2501 – STERILIZATION

1.1 INTRODUCTION

Before being placed into service and after successful hydrostatic pressure test, all newly constructed or repaired pipelines or structures, which will hold or carry potable water, shall be chlorinated and flushed or cleaned as directed by this specification and the Engineer. The Contractor shall chlorinate all pipelines and/or structures by use of liquid chlorine gas/water mixture or the use by use of calcium hypochlorite granules. All sterilization procedures shall be according to AWWA Standard C651-14.

Prior to chlorination all dirt and foreign matter shall be removed by thoroughly Preliminary Flushing or cleaning of the pipelines and/or structures.

1.2 PRELIMINARY FLUSHING

Prior to chlorination, pipelines shall be filled with water to eliminate air pockets and shall be flushed to remove all dirt and particulate matter. Contractor shall be responsible for providing means of measuring water such that a velocity sufficient to remove any and all debris is reached.

1.3 CHLORINE APPLICATION

All sterilization procedures shall be as specified below or as prescribed by AWWA Standard C651-14. The chlorine gas/water mixture shall be introduced into the pipelines or structure by means of an approved method by the Engineer and at such rate that all lines or structures contain a chlorine dosage of not less than 100 ppm. The retention time shall be not less than 24 hours and shall produce not less than 10 ppm at any point in the pipeline or structure at the end of the retention period. All valves, fire hydrants and appurtenances shall be opened and closed numerous times during the contact period.

Pipelines and structures may, at Contractors option, be chlorinated in sections isolated by means of gate valves or as approved by Engineer.

Chlorine gas/water mixture shall be dosed into the pipeline or structure to be sterilized by means of a tap and corporation stop placed onto the line as convenient to Contractor and approved by Engineer.

As a substitute to chlorine gas/water mixture, the Contractor may add calcium hypochlorite to the pipe as it is being installed. Such sterilization shall be achieved by placing the granules at the upstream end of the section to be tested and at 500' intervals at a dosage correlating to the sizes shown below:

Calcium Hypochlorite dosage per 500' of line	
Pipe Dia.	Calcium Hypo chlorite (oz.)
2"	0.42
4"	1.7
6"	3.8
8"	6.7
10"	10.5
12"	15.1
16"	26.8
18"	33.97
20"+	$D^2 \times 15.1$

*Where D is the inside pipe diameter in feet, $D = d/12$

After chlorination period is complete, all water shall be flushed from the pipeline or structure until it is equal quality to the existing supply and proved to the Engineer/Owner to be acceptable through Chemical and Bacteriological testing.

During the flushing period each valve and fire hydrant shall be operated numerous times to provide through flushing of the system and removal of all highly chlorinated water. The line shall set for a minimum of 48 hours following flushing at which time samples shall be pulled and stored in properly sterilized containers for bacteriological testing in a number to be determined by the Engineer and at the Contractors expense. The number of samples will be based on one sample per 4,000 linear feet of main and all dead ends. All bacteriological testing must be completed by a state-approved, certified laboratory. Per rule .1001. Upon receipt of successfully passing results, in duplicate, the line shall at the Engineers/Owners discretion be deemed acceptable.

Highly chlorinated water shall not be released into the existing distribution main or the surrounding environment. All water retained in the line shall be flushed until such time as the representative sample is identical to the existing water quality. All water shall be expelled from the lines and sprayed vertically so remaining chlorine is significantly dissipated through aerosolizing the chlorine or approved chemical dechlorination method as approved by the Engineer.

END OF SECTION

City Of Hickory

Section 2501-2

SECTION 2570 – BITUMINOUS PAVEMENT REPAIR

1.1 INTRODUCTION

The scope of this section is to furnish all labor, equipment, materials and any other items necessary to replace or repair all asphalt surfaces. All work shall be performed in conformance with the applicable sections of the North Carolina Department of Transportation, Division of Highways, “Standard Specification for Roads and Structures”(Latest Edition).

1.2 PERFORMANCE

Asphalt mixtures shall not be prepared or placed when the average ambient temperature is less than 40 degrees farenheight, during rainy weather, when sub grade or base course is frozen, when sub grade or base course is showing evidence of excess moisture or when the surface to be adjoined to is excessively moist and would prevent proper bonding with the new surface.

Preparation and construction of sub grade, base course and surface course shall be completed immediately after completion of all underground piping or structures, installation of curb and gutters, all yard piping, conduits and other facilities passing under paved areas and all structural slabs and foundations required within or adjacent to the paved areas.

1.3 INSTALLATION

A. Sub grade Preparation:

Sub grade preparation activities shall be in strict conformance with Section 500 or Section 505, where applicable, of the “Standard Specifications for Road and Structures” (Latest Edition) issued by NCDOT- Div. of Highways.

B. Aggregate base Course Installation:

Application of aggregate base course shall be in strict conformance with Section 520 of the “Standard Specification for Roads and Structures” (Latest Edition) issued by NCDOT- Div. of Highways.

C. Bituminous Plant Mix – General:

The work covered under this section of this specification shall be performed in strict conformance with Section 610 and Section 620 of the “Standard Specifications for Road and Structures” (Latest Edition) issued by NCDOT- Div. of Highways.

D. Prime Coat:

The work covered under this section of this specification shall be performed in strict conformance with Section 600 of the “Standard Specifications for Road and Structures” (Latest Edition) issued by NCDOT- Div. of Highways.

E. Tack Coat:

The work covered under this section of this specification shall be performed in strict conformance with Section 605 of the “Standard Specifications for Road and Structures” (Latest Edition) issued by NCDOT- Div. of Highways.

F. Bituminous Surface Course (S 9.5B):

The work covered under this section of this specification shall be performed in strict conformance with NCDOT Superpave specifications (Latest Edition) issued by NCDOT- Div. of Highways.

G. Traffic Markings:

The Contractor shall repair and restore any traffic markings that were damaged, destroyed or covered during the construction operation. All work shall be done in accordance with the requirements and specifications of NCDOT and in conformance with the MUTCD Manual (Latest Edition). The payment for work under this section shall be included in the unit bid price for bituminous surface coat and no additional payment will be made.

H. Existing Structures:

All existing structures which fall under or near repaired or restored bituminous areas shall be adjusted to final grade prior to application. All work under this section shall be included in the unit bid price for bituminous surface coat and no additional payment will be made if depicted on the plans. All encountered structures, which were not depicted on the plans or visible, will be paid at agreed upon price by Contractor and Engineer/Owner.

I. Testing and Acceptance:

All work in this section shall be subject to thickness and compaction tests as deemed necessary by the Engineer/Owner. All tests shall be included in the unit bid price for bituminous paving and paid by the Contractor. All tests found to be in nonconformance require the removal, replacement and restoration of areas in question. For additional tests requested by the Engineer/Owner, the Owner will pay for all successful tests and the Contractor shall pay for tests resulting in nonconformance and repair area as previously discussed. Compaction test shall be required as follows:

1. One test per intersection.
2. One test per road crossing less than 100 feet.
3. One test per 500 feet for excavations in a bituminous area.

Upon submittal of successful test reports and aesthetic acceptance, the Contractor shall be given an acceptance of the work in writing. The Contractor shall remain responsible for all improvements until final acceptance of the project.

END OF SECTION

SECTION 2660 – WATER SYSTEM

1.1 INTRODUCTION

The scope of this section is to furnish all labor, equipment, materials and all other items that are customary and normally required to install and complete installation of ductile iron, polyvinyl chloride (PVC) and copper water lines in accordance with the plans. All pipe and incidental material shall be of the type specified in the plans and these specifications unless written variance is granted by the Engineer. All pipe storage/handling, excavation, bedding, laying, jointing and backfilling shall be accomplished as specified herein. Payment shall be made as depicted in the unit prices and measured as the actual laying length with no deduction for valves or fittings.

1.2 CATALOG CUTS SUBMITTALS

Contractor shall submit 4 copies of catalog cuts to Engineer for review for all materials that are required to complete the work as described in the associated plans. Engineer will retain two sets of original submittals and return two sets to the Contractor with the appropriate response annotated.

1.3 STORAGE AND HANDLING

The Contractor shall inspect the materials upon receipt for visible defects prior to off loading. The Contractor shall unload pipe so any deformation or other injury to the pipe is avoided. The Contractor shall implement appropriate measures during storage such that no storm water may pass through or encumber the materials. Pipe shall not be rolled or dragged over gravel, rock, asphalt or concrete during handling or staging. In the event of damaged material, the damaged section may be cut away from the undamaged section and disposed of with the undamaged portion being used. The Engineer may reject material that is severely damaged or injured in whole or part. In no event shall any pipe or material be placed along the project site by rolling off a truck or trailer and allowed to strike the ground. Striking pipe or material in this manner will damage the pipe, material, lining or casting of same and will be deemed defective and rejected by the Engineer.

If defective material is discovered after installation, it shall be removed and replaced or repaired with acceptable materials by the Contractor at their sole expense.

1.4 MATERIALS

A. Pipe size less than 3” diameter that is installed below grade and outside building shall comply with one or more of the following:

1. Seamless Copper Tubing: Type “K” roll form to comply with ASTM B 88-62 and installed with wrought copper (95-5 Tin Antimony solder joints) fittings in accordance with ANSI B16.22.
2. Polyvinyl Chloride Water Pipe: Pipe shall conform to ASTM D 2241 with SDR 21 rating or SCH 13.5 and shall be continually marked with manufacturer’s name, pipe size, cell classification, SDR rating and

ASTM D 1748 classification. Pipe joints shall be integrally molded bell ends in accordance with ASTM D 3139 with factory supplied elastomeric gaskets and lubricant.

B. Pipe size larger than 3" that is installed below grade and outside building shall comply with one of the following as depicted on the plans:

1. Ductile Iron Pipe:

All materials shall be true to theoretical form throughout, first quality with smooth interior and exterior and free from imperfections. All materials shall be available for inspection by the Engineer/Owner at any point from production to installation for the purpose of rejecting defective materials or altering to meet intended specification. All rejected material shall be immediately removed from the project site upon written notice from the Engineer.

All cited or referenced specifications or standards shall be the latest revisions under that identification or in the case of abandoned standards any such superseding standard. This shall be true for all specifications or standards except such requirements that clearly are not applicable.

Ductile iron pipe shall be manufactured in accordance with AWWA Standard C151. All Ductile iron pipe shall be class 350 psi unless specified differently on the plans and shall contain a cement mortar lining, unless specified differently on the plans, not less than 1/16" thick as specified in AWWA Standard C104. Wall thickness for all ductile iron pipes shall be in conformance with AWWA Standard C150. Standard laying conditions shall be assumed to be type 2 unless specified differently on the plans. The exterior of pipe shall be coated to a thickness of not less than 5 mils, as specified in AWWA Standards C110 & C115, with an asphaltic material.

1. a. Flanged Joints:

Flanged pipe shall have flanges with long hubs, shop fitted on the threaded end of pipe, shall be 125 lb. rated and accurately faced at right angles to the pipe axis so a complete fit is readily obtained. When required, flanges shall be tapped for stud bolts. The face of all flanges shall be drilled smooth and true and completely coated with coal tar finish, varnish or other approved anti-corrosion agent. Immediately prior to installation, flange faces shall be cleaned with a wire brush until the face is significantly consistent of bare metal.

Ductile iron flanged joint pipe shall conform to AWWA Standards C110 & C115 and shall have a minimum thickness of Class 53. Flanged end pipe shall be accurately measured and ordered so that no field cutting of pipe is necessary unless specifically approved by the Engineer. Unless approved no field alteration of flanged pipe will be allowed. Attempts to field cut pipe shall result in immediate rejection of all material affected. All flanged joints shall be properly aligned with no external force applied to the pipe or flange to achieve alignment. All bolts and gaskets shall be furnished by the Contractor installing the pipe for all joints, including such joints as the Contractor may be connecting to equipment or appurtenances which they did not supply or install.

Flanged joints shall be jointed with properly sized and type bolts as recommended by the manufacturer. Stud or tap bolts shall be used only as indicated on the plans. Steel or tap bolts shall be cadmium plated with true and sound fitting threads. Cadmium plating shall be by an approved process with a thickness of 3 to 5/10,000 of an inch. The Contractor, upon request, shall supply written confirmation of plating to the Engineer.

1. b. Mechanical Joints:

All mechanical joint pipe shall be manufactured in accordance with AWWA Standard C111, C151 and C150 as applicable with a rating of class 350 psi.

All bolts shall be finish tightened by means of a torque wrench to the specified torque as recommended by the manufacturer in such a manner as the pipe is sealed evenly around to the joint. If effective sealing is not obtained by following the above procedures then the joint shall be disassembled, cleaned and reassembled following the above procedures.

Bolts shall be high-grade steel, low alloy type with tee head and American Standard threads. Mechanical joint gland shall be cast iron and gasket shall be plain rubber.

1. c. Slip Joints:

Slip joint pipe shall be manufactured in accordance with AWWA Standards C 151 & C 150 as applicable with a rating of class 350 psi.

Bells of pipe shall be contoured to receive a bulb shaped circular rubber gasket and spigot end shall have sufficient taper to facilitate installation. Jointing shall be achieved by lubricating joint with approved lubricant, guiding spigot end of pipe into bell end of adjacent pipe until contact is made with gasket and exerting enough compressive force to drive the spigot forward into the bell until they achieve full contact. No joint shall exceed the maximum deflection allowed by the manufacturer, normally 8" in an 18' joint.

1. d. Restrained Joint:

Restrained joints shall consist of standard ductile iron slip bell with gaskets containing metal wedges. Wedges shall be manufactured of stainless steel and the gasket rubber shall be manufactured in accordance with ANSI/AWWA C111/A21.11. Bells shall be manufactured in accordance with ANSI/AWWA C153/A21.53. The joints shall be designed for a working pressure of 200 psi. Restrained joints shall be American "Fast Grip", U.S. Pipe "Field-Lok", or approved equal.

1. e. Ball and Socket Joints:

When specified ductile iron ball and socket joint pipe shall conform to AWWA Standards C150 & C151 as applicable and shall have a minimum thickness class of 55. The spherical socket shall be manufactured with applicable material requirements of ASTM A536 and threaded onto the ductile iron pipe barrel with threads conforming to ANSI B2.1 adapted to standard ductile iron pipe. The ball end of joint shall be integrally cast with the pipe barrel and accurately machined to fit into the adjoining pipe socket and provide constant compression of the gasket through deflection of up to 15 degrees of the assembled joint and shall maintain a watertight joint in all directions. The inside surface of the ball shall be shaped so that the waterway shall not be significantly impacted at any degree of deflection. A substantial external locking ductile iron gland shall prevent longitudinal separation.

Ball and Socket joints shall be American "Flex-Lok", U.S. Pipe "USIFLEX", or approved equal.

2. Fittings:

All ductile iron fittings shall be in conformance with AWWA Standards C110 & C111 for underground piping as applicable and shall be mechanical joint type unless otherwise specified on the plan. If flanged pipe is specified then it shall be in conformance with AWWA Standard C110 for exposed piping.

All fittings shall be manufactured in conformance with AWWA Standards C111 & C104 as applicable and shall be cement mortar lined unless otherwise specified on the plans. All fittings shall have rated working pressure of 250 psi unless otherwise specified on the plans.

3. Polyvinyl Chloride Pipe (PVC)

All materials shall be true to theoretical form throughout, first quality with smooth interior and exterior and free from imperfections. All materials shall be available for inspection by the Engineer/Owner at any point from production to installation for the purpose of rejecting defective materials or altering to meet intended specification. All rejected material shall be immediately removed from the project site upon written notice from the Engineer.

All cited or referenced specifications or standards shall be the latest revisions under that identification or in the case of abandoned standards any such superseding standard. This shall be true for all specifications or standards except such requirements that clearly are not applicable.

3. a. PVC Pipe 4" Diameter and Larger:

All PVC pipe 4" and larger shall be manufactured in conformance with AWWA Standard C900, ASTM 2241 and shall conform to the requirements of DR 18 class 235 psi or DR 14 class 305 psi. The exterior of all PVC shall bear a continuous stamp indicating the AWWA certification, DR ratio, size and manufacturer.

All PVC shall have a bell with integral rubber gasket and be slip joint manufactured in accordance with AWWA C151.

Bells of pipe shall be contoured to receive a bulb shaped circular rubber gasket and spigot end shall have sufficient taper to facilitate installation. Jointing shall be achieved by lubricating joint with approved lubricant, guiding spigot end of pipe into bell end of adjacent pipe until contact is made with gasket and exerting enough compressive force to drive the spigot forward into the bell until they achieve full contact. No joint shall exceed the maximum deflection allowed by the manufacturer, normally 11" in a 20' joint.

4. Fittings:

All ductile iron fittings shall be in conformance with AWWA Standards C110 & C111 for underground piping as applicable and shall be mechanical joint type unless otherwise specified on the plan. If flanged pipe is specified then it shall be in conformance with AWWA Standard C110 for exposed piping.

All fittings shall be manufactured in conformance with AWWA Standards C111 & C104 as applicable and shall be cement mortar lined unless otherwise specified on the plans. All fittings shall have rated working pressure of 250 psi unless otherwise specified on the plans.

1.5 INSTALLATION

A. Excavation:

This section shall cover the excavation and proper disposal of any and all materials disturbed during the construction of trenches which is further defined as all excavation necessary for the proper installation of storm or sanitary sewers and any appurtenances and waterlines and any appurtenances. This section shall further cover any work deemed appropriate by the Engineer.

Excavation shall be done to the lines and grades as depicted or detailed on the plans or as directed by the Engineer. All work involving this section shall be coordinated with any Grading, Site Utility work or other construction on the project site and shall be maintained satisfactorily so that adequate drainage is provided at all times. Any roots that protrude into the trench lines shall be trimmed flush with the trench walls.

All excavation shall be open cut unless otherwise depicted on the plans or specifically authorized by the Engineer. If after excavation the bottom of the proposed trench is found to contain rock, materials which cannot be removed with standard and prudent construction equipment or is unsuitable for providing a uniform bearing surface then same material shall be removed to a depth not less than 8" below proposed depth, backfilled with approved material and compacted. Excavation widths shall be such that not less than one full diameter of the pipe is clear between the outside face of the pipe and each closest trench wall or inside face sheeting, shoring, or trench box as necessary.

Excavated materials to be used during backfill operation shall be suitable material, significantly free from debris and/or rocks and approved by the Engineer. Acceptable material which is excavated shall be neatly and compactly deposited at the sides of the trench where space provides but at no time closer than 2'0" from the closest side of the trench. When stockpiling of material is required, the Contractor, at his expense, shall do so at an approved site and this site shall be kept neat to avoid unsightly appearance. Stockpiling shall be arranged to allow for natural drainage without pollution of water by erosion.

Protection of existing pavement structures from damage due to staining from excavated material and to improve cleanup shall be obtained by placing a 1” layer of sand or rock dust over all asphalt or concrete surfaces which are planned or reasonably anticipated to have excavated material directly on during construction.

B. Sheeting, Bracing and Trench Boxes:

As appropriate reference to OSHA Regulation 1926.652(b), the Contractor will be required to keep the sides of excavation vertical by sheet, bracing or the use of trench boxes to prevent movement by slides or settling of the side, to prevent injury or displacement of pipe or appurtenance or diminished the required working space adjacent to pipe. Furthermore, the Contractor may be required, for the purpose of preventing injury to persons, property or adjacent structures, to leave sheeting or bracing in place.

All measures employed, when required, shall extend a minimum of 18” above existing grade and a maximum of 48” above grade. In no case shall timbers, beams or other sheeting/bracing materials be left in the trench, which may form or promote voids that cannot easily be corrected during the backfilling operation or compaction of backfill. It is agreed upon by these specifications that where it is necessary to leave sheeting or bracing intact and backfilled that the Owner is under no obligation to pay Contractor for time or materials involved in constructing such measures. Contractor shall assume and accept any and all risk associated with or encumbered by failure to implement proper and necessary sheeting, bracing or trench box use on any excavation and will be held responsible for caving, settlement and all other damages resulting there from.

C. Foundations:

Trench foundation shall be “Type 2” as defined in AWWA Standard C151 unless otherwise noted on the plans. Pipe bedding shall be as shown in the plans for the typical cross section for the type of pipe and location for which it is being installed. Pipe foundation shall be uniformly firm and compacted and shall be consistent with lines and grades as detailed on the plans.

Trench bottom shall be formed to follow the bottom third of the pipe, where soil conditions allow. All installations shall conform to a uniform bearing surface throughout the length of the pipe to fully and evenly support the barrel of the pipe. Bell holes shall be excavated under each bell of each joint such that no undue stress is borne by the bell of pipe thus leading to damage of the material. If undercut is required due to unsuitable soil, rock or through normal construction then suitable material shall be replaced and compacted with uniform support of the pipe provided for the entire length of the pipe. At no time shall undercut for rock be less than 8" from the proposed grade so to prevent future damage. Undercut limits for unsuitable material for supporting pipe loading shall be determined by and constructed according to the Engineer. Continued unsuitable soil may require replacing bottom of trench to grade with washed stone or, in extreme cases, concrete cradles. If washed stone or concrete cradles are specified then the Engineer, at unit price for materials, shall allow additional compensation to the Contractor.

The Contractor shall remove all water that may be encountered or which may accumulate in the trenches by pumping or bailing and no pipe shall be laid until the water has been successfully removed from the trench. Water so removed from the trench shall be disposed of in a manner as not to cause injury to completed work, work in progress or any adjoining area.

D. Installing Pipe:

All installation practices should be in strict conformance with the manufacturer's recommendations, AWWA Standards C600 and C605, and the construction specifications. Where any conflicts exist the Contractor shall inform the Engineer immediately and the applicable AWWA Standard shall take precedence. The Engineer shall be furnished installation manuals for any such product that a discrepancy arises or they deem appropriate.

Customary and reasonable tools, implements and facilities satisfactory to the Engineer shall be provided and used for the safe and progressive installation of pipe. All pipe, fittings, valves and other materials shall be hoisted into trench by means which are acceptable and are not conducive to injury of pipe, fittings, valves, and any other materials or their protective coatings or dangerous to any personnel who may be in the trench or vicinity. All pipe hoisted into the trench shall be clean and free from defects. Pipe shall be laid on the prepared foundation so as a straight, uniform flow line exists upon completion.

When cutting pipe lengths are necessary, the Contractor shall practice normal and prudent care so that all cuts are at right angles to the flow line of the pipe. If a skewed cut is specified then the Contractor shall perform the cut as required by the plans. All slip joint pipe which is cut shall be ground to a taper on the cut end to match the manufacturer's taper so pipe may be jointed as intended by the manufacturer.

All PVC pipe installed shall be chased continuously with a 14 gauge stranded, coated copper wire with the coating being royal or light blue. Wire shall be pulled taut so as to prevent damage from backfill and compaction operation or re-excavation in the future. Wire shall be taped no less than every 10 feet and at the taper of every bell end. Wire shall be pulled into every valve box with no less than 2x the depth of bury in length of wire left in the box for future connection to facilitate location. Wire shall be extended in an identical manner along fire hydrant legs and extended along the barrel to ground surface and looped around the base of the upper section at the flange.

Pipe joints shall be sound and in strict compliance with the manufacturer's recommendations. Maximum deflection allowed shall be as allowed by the manufacturer but at no time should be greater than 2 degrees or 8" per 18' joint without special expanded deflection bells being provided. All pipe which is damaged, broken or will not join shall be removed immediately and stockpiled for inspection by the Engineer. Pipe that is damaged during backfill or compaction operations shall be removed and replaced or repaired as directed by the Engineer.

All water lines shall have a minimum 12" vertical separation from storm sewer and shall have a minimum vertical separation of 18" from sanitary sewer when crossing. When crossing sanitary sewer lines the waterline shall cross above the sanitary sewer line. Horizontal separation of 10'0" shall be maintained from all sanitary sewers. If separations cannot be maintained then the Engineer shall be notified and both the waterline and sanitary sewer line shall be constructed of ferrous material such as ductile iron.

Pipe shall not be installed except in the presence of the Engineer or at his specific direction. In the event pipe is installed without the specific direction of the Engineer, then the Contractor may be required to clean, test, uncover for inspection or remove the sections as directed by the Engineer.

1.6 BACKFILL AND COMPACTION

A. Trenches shall be backfilled immediately upon approval of pipeline construction.

B. Roadways and Crossing:

Full depth and width of trench shall be backfilled by placing material in uniform layers not to exceed 12" thick and shall be thoroughly compacted by approved mechanical compactors under optimum moisture conditions. Compaction of the trench shall be to 95% as determined by Standard Proctor Test for all areas outside the paved area and any depth exceeding 18" below finished surface of asphalt. The top 18" of any trench directly under pavement or within 36" of the edge of pavement shall be compacted to 100% as determined by Standard Proctor Test. If existing material is not suitable for obtaining compaction then select backfill shall be used when requested by the Engineer.

All paving and base course affected shall be removed and replaced with new material of equal or better quality with like texture and color as the adjacent pavement.

All backfill methods shall be in strict compliance with manufacturer's recommendations and all methods shall be instituted such that no damage, misalignment, or unjointing of the pipe or appurtenances is experienced. Backfill shall be kept free of organics (grasses, sticks, stumps, roots etc.), stones (all stones over 1" diameter within first 12" of backfill and all stones over 2.5" diameter for the remainder of the backfill), any frozen soil or other soil which is not suitable for backfill (highly plastic clay) or any other objectionable items. All backfill shall be installed and graded in a manner that erosion or saturation will not negatively affect the backfilled area.

Heavy equipment shall not be operated over any pipe or appurtenance until it has been properly backfilled and has minimum cover as required by the plans. Where any part of the required cover is above proposed finished grade, the Contractor shall place, maintain and lastly remove such material at no additional cost to the Owner. Any pipe or appurtenance, which becomes misaligned, shows excessive settlement or has been damaged by the Contractor shall be corrected or replaced as deemed necessary by the Engineer/Owner at no additional cost to the Owner.

Prior to acceptance, the Contractor shall properly maintain all installations in such a manner that they will operate without failure.

C. Finish Grading:

All areas disturbed shall be graded to a continuous finish without irregularities or abrupt changes and shall not consist of areas, which will retain water or cause foreseeable future maintenance. Prior to acceptance, all debris, excess material, trash or any unsightly occurrence shall be removed and the project site shall be in a neat and satisfactory condition.

Cleanup and seeding is part of the pipeline installation. No more than 4,000 linear feet of waterline may be laid prior to completion of cleanup of the first section of pipeline laid. During construction no more than 4,000 linear feet or 2 weeks' time may pass before cleanup and seeding is performed.

END OF SECTION

Section 2660 - 10

SECTION – 02661 WATER SYSTEM DESIGN

Part I General

- 1.1 General Description: This section covers the acceptable design principles, system requirements and system specifications section references for water system design and layout.
- 1.2 General Intentions: The work covered under this section includes standards and general regulations for water system references, component sizing, professional involvement and layout.
- 1.3 All water system improvements shall be designed, significantly inspected, tested, and certified to NCDEQ and System by a North Carolina Licensed Professional Engineer.
- 1.4 Record Drawings, release of liens, consent of surety, Engineer's certification, approved/witnessed static pressure test and approved/certified Bacteria test are ALL required as minimum documents for system to be accepted for addition to Public Water System. Absence of any one document shall be grounds for non-approval.
- 1.5 All system improvements shall be installed in accordance with these and all referenced specifications and shall become the sole benefit and responsibility of the Public Water System upon completion and acceptance.
- 1.6 In the event of donated systems, the developer shall submit a written request to the Public Utilities Director requesting acceptance of the system by the Public Water System detailing the length, material and construction cost.
- 1.7 All donated systems shall have a one-year workmanship and materials warranty.

Part II Referenced Specifications

- 2.1 North Carolina Department of Environmental Quality Public Water Supply Minimum Design Criteria.
- 2.2 City of Hickory Water System Construction Specification Sections: 02222, 02227, 02668, 02400, 02401, 02402, 02500, 02501 and 02660.

Part III Plan and Specification Submittal

- 3.1 North Carolina Department of Environmental Quality Public Water Supply Minimum Design Criteria shall be followed.
- 3.2 The Public Utilities Director or Authorized Representative shall approve all plans and specifications for waterline extensions.
- 3.3 All waterline extensions connecting to the Public Water System or any Tributary system shall be permitted as required by NCDEQ under the signature of the Public Water Supply Authorized Representative.
- 3.4 No waterline extensions shall be allowed without prior written consent of the water availability and plans and specification approval by the Public Utilities Director.

City Of Hickory

- 3.5 All plans and specifications submitted shall be reviewed and approved, approved with notes or disapproved, as appropriate, within 20 days of submittal and returned to the submitting Professional Engineer.
- 3.6 Upon receipt of returned plans, professional engineer will respond appropriately and resubmit to Public Utilities Director with completed NCDEQ-PWS Waterline Extension Application (Current Edition), Engineer's Report and corrected copy of plans.
- 3.7 Submitting Professional Engineer shall complete all necessary encroachments, permits, reports, submittals, revisions etc. as may be required to obtain project approval to begin construction.

Part IV Minimum Line Size

- 4.1 No line smaller than 8-inches in diameter shall be extended to dead-end.
- 4.2 Waterlines 6-inches in diameter or smaller are allowed only with approval of Public Utilities Director and only in the event of looped conditions between lines of larger size and feed from different sources.
- 4.3 Fire hydrants shall not be placed on lines smaller than 6-inches in diameter.
- 4.4 Waterlines 2-inches in diameter are allowed only with approval of the Public Utilities Director and in the following cases:
 - a. 1,000 linear feet or less in length.
 - b. Main line blow-off installed on end.
 - c. No possibility of future extension to serve other properties.
 - d. No more than 20 residential service connections on the line.
- 4.5 Two-inch waterlines may be looped to allow for up to 40 residential service connections as approved by Public Utilities Director.
- 4.6 Phased Construction of waterlines must be extended to the furthest side of the last property being served by that phase.
- 4.7 Waterline extensions proposed must be sized to serve property in basin.
- 4.8 Waterlines that may be extended to serve future properties shall be minimum of 8-inches in diameter.
- 4.9 Master Meters are allowed for Townhome, Condominium, Apartment or Multi-Tenant Office use as approved by the Director.
- 4.9.1 Service Connection Meters shall be sized to meet the current NC Building Code as a minimum, with the following sizes being required based on AWWA Manual M6, current edition, and NCAC 15A: 18C.0802 and .0902:
 - a. 2-inch meters shall not serve in excess of 16 residential units, or equivalent.
 - b. 3-inch meters shall not serve in excess of 28 residential units, or equivalent.
 - c. 4-inch meters shall not serve in excess of 50 residential units, or equivalent.

Part V Approvals

- 5.1 All waterline extensions shall be designed by a NC licensed Professional Engineer, reviewed and approved by the Public Utilities Director of the Public Water System, permitted by the Authorized Representative of the Public Water System through NCDEQ and all other agencies.

City Of Hickory

Part VI Ownership and Maintenance

- 6.1 The Public Water System will assume sole benefit and responsibility of the improvements once all sections of the specification have been satisfied.

END OF SECTION

Section 02661-2

SECTION 02668 - WATER SERVICE CONNECTIONS

1.0 DESCRIPTION:

Water service connections shall include tapping the main line and providing all saddles, corporation stops, fittings, service lines, copper setters, meters, meter boxes and other incidentals required for proper installation.

1.1 Related Work: See the following sections for related specifications.

Section 02933 – Seeding and Mulching

2.0 MATERIALS:

Shop drawings, catalog cuts and related data for service pipe and appurtenances shall be submitted to the Director of Public Utilities for approval.

2.1 Copper Setter (Meter Setter): shall be of copper and brass, domestic manufacture and of the proper size for the service on which they are installed. The setters shall be equipped with a double check valve outlet and padlock wings on the key valve. $\frac{3}{4}$ " – 1" copper setters shall be Mueller H1404-2A or approved equal. $1\frac{1}{2}$ " - 2" copper setters shall be Mueller H1423-2A or approved equal.

2.2 Corporation Stops: shall be of brass, domestic manufacture and of the proper size for the service on which they are installed. Where dictated by the tapping angle, eighth or quarter bend couplings shall be provided. Suitable brass adapters for coupling to service pipe shall be provided. Corporation stops shall be Mueller 300 B-25008 or approved equal.

2.3 Tapping Saddles: shall be of ductile iron saddles with double high tension, low alloy steel straps. Tapping saddles shall be Romac style 202, Mueller BR2-B, or approved equal.

2.4 Service Pipe and Fittings:

2.4.1 Polyethylene Tubing:

Tubing: AWWA C901, Polyethylene (PE3408), Pressure Pipe (Class 200), DR=9

Fittings: AWWA C901, fusion or compression connection

2.4.2 Copper Tubing:

Tubing: ASTM Specification B-88, Type K, Seamless, Annealed

Fittings: AWWA C800 flared or compression fittings

2.5 Pipe Connection Clamps: shall be of stainless steel.

2.6 Meters:

2.6.1 General: All meters shall be Neptune Compound meters or approved equal.

2.6.2 Certification: The meters are to be accepted on a certificate furnished by the Manufacturer that meters have met the requirements of the Standard Specifications for Water Meters, as adopted by the American Water Works Association (AWWA).

2.6.3 Delivery: Registers shall be direct reading with sweep hand and shall record in cubic-feet and totalized on five odometer wheels. The registers shall be of the hermetically sealed gear train and register type with magnet drive.

2.6.4 Guarantee: Each and every meter shall be guaranteed for a period of no less than one year from date of purchase against faulty material and workmanship. Hermetically Sealed Registers shall be guaranteed for a ten-year period.

2.7 Meter Boxes: shall be 18" deep Fastec MBX-1 cast iron, or approved equal, for $\frac{3}{4}$ " and 1" meters. Meter Boxes for 1 $\frac{1}{2}$ " and 2" meters shall be Fastec MBX-5 cast iron, or approved equal. Lid of meter box shall clearly be marked "Water".

3.0 INSTALLATION: Service connections shall be installed at locations as designated by the Owner. Installation shall be made in a manner acceptable to the Director.

3.1 Taps: Proper size taps shall be made on the distribution line. A corporation stop, with the proper bend and service pipe adapter, shall be installed in the tap.

3.2 Backfill: Ditches and cleanup of the work area shall meet approval of the Director.

END OF SECTION

SECTION 2900 – RESTORATION OF SURFACES

1.1 INTRODUCTION

The scope of this section is to furnish all labor, equipment and materials necessary for the proper restoration of existing surfaces disturbed or damaged as a result of any construction activity not specifically detailed for other landscaping or restoration in any other part of this specification. Any damage to existing surfaces or structures shall be restored to original condition or better using like materials and workmanship to the original.

1.2 INSTALLATION

All pervious surfaces shall be dressed smooth and seeded in strict accordance with the section of these specifications entitled Seeding and Landscaping. Shoulders of all roads shall be restored as specified for lawns. Wooded areas or fields shall be restored raked smooth and seeded as specified in the section entitled Seeding and Landscaping.

A. Ditches:

Ditches shall be regarded to the original grade or such grade that flow is maintained to prevent ponding or standing water. If the grade must be altered, the Engineer shall approve the final grade and all adjacent slope grades with the Contractor performing the work as directed by the Engineer. The surface of all ditches shall be returned to the same condition as found before commencing work. The unit price for this work shall be encumbered in pipeline installation prices.

B. Concrete Walks:

Concrete walks removed or damaged as a part of the construction operation shall be replaced with new Class B concrete formed and poured in place and installed to match the original line, grade and general appearance of the existing walk. Concrete shall be poured to match the original walk thickness, but not less than 4” thick, over a thoroughly compacted and leveled sub grade. Walks shall be float finished, edged with an edging tool and grooved at intervals to match the existing walk, or at intervals not exceeding the width, uniform throughout the length of the replacement measured in one direction. This work shall be paid at unit price.

C. Driveways

Concrete drives removed or damaged as a part of the construction operation shall be replaced with new Class B concrete formed and poured in place and installed to match the original line, grade and general appearance of the existing drive. Concrete drives shall be poured the same thickness of the original drive, but not less than 4” thick, and shall contain reinforcing steel, mating, etc. to match the original drive. Prior to placing the concrete a 4” aggregate base course shall be placed in the drive area and leveled. The Contractor shall be responsible for coordinating restoration with property owner and allowing for curing time.

Bituminous or Asphaltic concrete drives shall be restored to the original base and asphalt thickness. As a minimum, all bituminous or asphaltic concrete drives shall consist of 6" base course and 2" surface material. Base material shall be thoroughly compacted and leveled to provide the appropriate depth of support and surface material shall be compacted in 2" lifts and topped with the appropriate depth to match the existing surface grade. All work done under this provision shall be performed in accordance with the section entitled Bituminous pavement Repairs. The Contractor shall be responsible for coordinating restoration activities with the property owners.

All unpaved drives shall be surfaced with not less than 4" of Crusher-run gravel and topped with similar surface material as the existing drive. The final drive shall consist of the 4" base and not less than 3" of surface material to match the existing drive. All unpaved drives shall be restored to a condition better than the original when encountered.

All drives shall be temporarily replaced with 4" of Crusher-run installed level with the existing drive surface and maintained until such time as the permanent drive can be restored. Restoration should not take more than three weeks without approval from the Engineer/Owner.

D. Roadway Replacement

Bituminous or Asphaltic pavements shall include all areas paved with blacktop; built-up pavements, oil and stone, tar and stone or any similar pavements constructed with a bituminous or asphalt and stone material.

Immediately upon completion of installation of underground piping and structures, the trench shall be backfilled and compacted to specification and roadway shall be repaired. The excavated area shall be restored to match the original material. In the case of tar and stone, oil and stone or other unprocurable material the repair shall consist of asphalt repair. The repair shall consist of a 12" aggregate base course, and a 4" surface course as defined in the specification entitled Bituminous Pavement Repairs. If Engineer deems appropriate then the Contractor may be allowed to surface treat damaged pavements outside of the excavation without removal of existing surface and base courses by overlaying the area in question and matching back to the existing surface.

Portland cement concrete road surfaces shall be replaced with Class B concrete and shall have equal thickness and reinforcing steel as the original roadway. Prior to placing concrete an aggregate base course of 6" thickness shall be placed and compacted.

The Contractor shall repair or replace any and all traffic markings damaged, removed or covered during construction. All existing manholes or valve covers shall be raised to finished grade prior to paving to prevent covering of existing infrastructure. The Contractor shall include this work as a part of the project and shall not seek additional compensation outside of the original unit prices. All such inquiries shall be requested and approved by the Engineer.

All differential settlement shall be corrected immediately as directed by the Engineer and the Engineer shall approve corrections.

All work under this category shall be performed in accordance with NCDOT Standards and shall be subject to inspection by the local representative for conformance with the requirements and specifications.

E. Lawns and Landscaped Areas

All lawns and disturbed area shall be regarded to match the existing grade prior to construction. Lawns, as previously defined, shall be graded, seeded and fertilized in strict conformance with the section of this specification entitled Seeding and Landscaping. Top soiled areas shall be replaced with topsoil of equal or better quality and quantity.

All shrubs, hedges, ornamental trees, flower or other items constituting landscaping shall be replaced to the original condition with the same items as removed or similar materials at property owner's approval.

F. Curb and Gutter

Curb and gutter sections removed, damaged, destroyed or otherwise impacted by the construction operation, Contractor or his agents shall be replaced with new Class B concrete to a condition matching or similar to that existing before construction activities. If curb and gutter cannot be matched exactly to the original condition, the Engineer shall approve alteration.

G. Damage to any Structure

All damage to existing structures shall be repaired by materials and workmanship equal to the original construction. At the direction of the Engineer, sufficiently damaged structures may require total replacement to the extent deemed appropriate by the Engineer. The Engineer shall approve all such replacements and unless otherwise noted separate payment for the repair or replacement will not be allowed.

END SECTION

SECTION 2930 – SEEDING AND LANDSCAPING

1.1 INTRODUCTION

This section covers the furnishing of all labor, equipment, material and any other items necessary for landscaping of all areas of the site disturbed by construction operations and all earth surfaces of embankments including rough and fine grading, topsoil if required, fertilizer, lime, seeding and mulching. The Contractor shall adapt his operations to variations in weather or soil conditions as necessary for successful establishment and growth of grasses or legumes.

1.2 CATALOG CUT SUBMITTALS

Contractor shall submit 4 copies of catalog cuts to Engineer for review for all materials that are required to complete the work as described in the associated plans. Engineer will retain two sets of original submittals and return two sets to the Contractor with the appropriate response annotated.

1.3 STORAGE AND HANDLING

Contractor shall take all prudent and customary measures to ensure that all materials stay moisture free and are not degraded by storage or handling. All lime and fertilizer shall be kept free from hardening or caking and if this occurs they shall be pulverized to their original state. All seed shall be further protected such that it is not subjected to heat or rodents. If degradation occurs and the materials no longer hold the mineral values advertised then they shall be removed from the site and new materials applied.

1.4 MATERIALS

A. Lime

The quality of lime and all operations in connection with the furnishing of this material shall comply with the requirements of the North Carolina Lime Law and regulations adopted by the NC- Board of Agriculture.

Lime shall be agriculture grade ground dolomite limestone. It shall contain not less than 85% of the calcium and magnesium carbonates and shall be of such fineness that at least 90% will pass a No. 10 sieve and at least 50% will pass a No. 100 sieve.

B. Fertilizer

The quality of fertilizer and all operations in connection with the furnishing of this material shall comply with the requirements of the North Carolina Fertilizer Law and regulations adopted by the NC- Board of Agriculture.

Fertilizer shall be 10-10-10 grades. Upon written approval of the Engineer a different grade of fertilizer may be used, provided the rate of application is adjusted to provide the same amounts of plant food.

C. Seed

The quality of seed and all operations in connection with the furnishing of this material shall comply with the requirements of the North Carolina Seed Law and regulations adopted by the NC- Board of Agriculture.

The NC-Dept. of Agriculture shall have approved seed or any agency approved by the Engineer before being sown, and no seed will be accepted with the date of test more than 9 months prior to the date of sowing. Such testing does not relieve the Contractor from responsibility for furnishing and sowing seed that meets these specifications at the time of sowing. When a low percentage of germination causes the quality of seed to fall below the minimum pure live seed specified, the Contractor may elect, subject to approval of the Engineer, to increase the rate of seeding sufficiently to obtain the minimum pure live seed contents specified, provided that such an increase in seeding does not cause the quantity of noxious weed seed per square yard to exceed the quantity that would be allowable at the regular rate of seed.

Seed shall be entirely free from bulbets or seed of Johnson Grass, Nutgrass, Sandbur, Wild Onion, Wild Garlic and Bermuda Grass. The specifications for restricted noxious weed seed refers to the number per pound, singly or collectively, of Blessed Thistle, Wild Radish, Canada Thistle, Corncockel, Field Bindweed, Quackgrass, Didders, Dock, Horsenettle, Bracted Plantain, Buckhorn or Wild Mustard; but in no case shall the number of Blessed Thistle or Wild Radish exceed 27 seeds of each per pound.

D. Mulch

Straw shall be free of weed seed or any other species, which would be detrimental or deterring to specified grass maturation. Straw shall be from oat, rye or wheat species and threshed to limit seed content.

E. Tack

Emulsified asphalt or organic tack shall be applied uniformly over straw so as to ensure proper hold and give uniform appearance over the entire area. Tack shall be applied by spraying onto surface immediately after applying straw. Application rates will vary dependent upon conditions. Organic tack shall be used when the ambient temperature is below freezing

1.5 PREPERATION

A. Protection of Existing Vegetation

The Contractor shall not remove or damage vegetation, which is outside the Clearing Limits established by the Owner/Engineer or as displayed on the plans. All trees that are damaged and scheduled to remain shall be repaired in an acceptable manner promptly to prevent progressive deterioration. Vegetation which is scheduled to be replaced or is damaged beyond repair during construction operations shall be replaced with a similar size and species. Where this is not feasible the property owner shall be compensated for the vegetation damaged. Damage incurred during construction operations and due to insufficient protection shall be paid at the Contractors expense.

Existing vegetation not indicated for removal shall be protected against unnecessary cutting, breaking or skinning of roots, skinning or bruising of bark or smothering of vegetation by placing stockpiles of excavated material against the trunk or excessively over roots within the drip line. Vegetation shall also be protected against excessive vehicle or foot traffic within the drip line.

Roots cut during excavation shall be properly protected by either asphalt sealing or in some cases wrapping exposed roots in wet burlap to prevent drying.

B. Grading

Rough grading of the area shall be achieved as soon as the excavated area is backfilled and compacted. Rough grading shall be defined as all material restored which is required to bring the area to finish grade and acceptable surface drainage for storm water which provides for water to flow from the site in such a manner as that it does not place unusual risk to unsuspecting users of adjacent areas or inhabitants.

Fine grading of the area shall be achieved in a timely manner after completion of rough grading of the area. Fine grading shall consist of shaping final contours to ensure proper drainage and removing all debris or construction waste materials to provide an acceptable appearance. Construction area subject to finish grading shall have soil loosened to a depth of not less than 6 inches in a manner approved by the Engineer to promote seed growth. All finish landscaping shall be completed on a section-by-section basis where it is reasonable to expect completion of landscaping.

All grading, landscaping, and erosion control measures shall be properly pursued and maintained in order to maintain and acceptable appearance of the project. If such time occurs as this perception is degraded then the Engineer may suspend progress on the project until the issues are appropriately addressed.

C. Surface and Bed Preparation

The Contractor shall smooth or shape surface contours outside the project site when such contours are detrimental to the seedbed preparation or will pose foreseeable problems with future maintenance of the area. The Engineer shall direct the Contractor to what extent outside areas shall be affected or the Contractor may elect to work with individual property owners with written verification delivered to the Engineer/Owner of the agreement with the property owner's signature.

1.c Level Areas and Slopes Less than 2:1

The construction area shall have soil loosened to a depth not less than 6 inches and shall be free from all debris, clods and all other irregularities which would prohibit a smooth, shaped finish grade. Top 3 inches of soil shall be worked to a clod free finish suitable for planting seed.

2.c Slopes Greater Than 2:1

The construction area shall have soil loosened and acceptable for vegetation growth but the surface shall be free from all debris, clods and other irregularities. The surface may be track finished, scarified, grooved or punctured so as to provide a place for seed and other planting material to lodge. In the case of such slopes the Engineer may allow partial completion of the slope sections at different times to promote stabilization. If the vegetation growth is acceptable the Engineer may allow this to remain as the permanent ground cover.

The Contractor shall not pursue the finished preparation of surface areas to be landscaped if the soil is frozen, marginally wet or when the Engineer deems it unsuitable for working conditions.

D. Rate of Application

Seed shall be applied by means of Broadcast Spreader, Hydro-Seeder or other previously approved method. In no case shall seed, lime, or fertilizer be spread by hand. The rates of application for seed, lime and fertilizer shall be as follows, unless a variance is permitted by the Engineer in writing prior to performing work.

1.d Limestone

In the absence of a soil test performed at the Contractors expense and given to the Engineer on letterhead from the testing laboratory, Limestone shall be applied at the rate of 2000 lb/ acre.

2.d Fertilizer

In the absence of a soil test performed at the Contractors expense and given to the Engineer on letterhead from the testing laboratory, Fertilizer shall be applied at the rate of 1000 lb/ acre. Fertilizer shall be 10-10-10 grade, unless a variance is permitted by the Engineer in writing prior to performing work. A second application at 500-lb/ acre shall be applied to the area when the grass has reached a blade height of 3 inches or 45 days which ever comes first.

3.d Seed

The type and rate of application shall vary at different times of the year and shall be applied at the rate and type appropriate for the time of year. All rates of application are measured in pounds per acre.

a. Fall and Winter (Sept. 1 to May 1)

85 pounds of Ky-31 tall fescue mixed with 15 pounds of rye grain.

b. Spring and Summer (May 1 to September 1)

100 pounds of Ky-31 tall fescue mixed with 10 pounds of rye grain.

c. Cut of Fill slopes greater than 2:1

The application rate on cut or fill slopes greater than 2:1 shall include the appropriate mix above for the time of year along with; 40 lb/acre of sericea lespedeza (hulled in spring or summer and unhulled in fall and winter) and either 15 pounds of Sudan grass in spring and summer or 25 pounds of rye cereal per acre in fall and winter.

4.d Mulch

Mulch shall be straw mulch applied at a rate of approximately 3000 pounds per acre. Straw shall be applied at such rate necessary to thoroughly cover and protect all finish grading, seed, lime and fertilizer but not smoother the maturation of seed.

E. Application

Application of all limestone, fertilizer, seed and mulch shall be completed immediately following final preparation of the seed bed and shall not be pursued during a time when the Engineer deems weather to be non-conducive for seed growth, i.e. ground wet, frozen, etc. Lime, fertilizer and seed shall be distributed uniformly over the prepared seedbed at the specific rate of application and then harrowed, raked, or otherwise thoroughly worked or mixed into the seedbed. Immediately following the covering operation, the seedbed shall be properly compacted as directed in the manner and degree approved by the Engineer.

When a hydraulic seeder is used for application of seed and fertilizer, the seed shall not remain in water containing fertilizer for more than 1 hour prior to application unless otherwise permitted by the Engineer.

The Engineer may permit modifications to the requirements for covering or compacting lime, fertilizer and seed in the prepared seedbed if the Contractor requests modification due to height, steepness of slope or non-conductive soil conditions. Modifications may be considered in the case of: Slopes greater than 2:1 and Slopes where surface is too rocky to successfully permit compaction or covering of the seedbed. Modifications may be permitted to include reduction of application rates and reduction or elimination of compaction requirements.

All equipment normal and prudent for the preparation of seedbed and uniform distribution of lime, fertilizer and seed shall be approved by the Engineer prior to use on the project. In the event of malfunctioning or improperly maintained equipment, the Engineer reserves the right to suspend work on the project until such time as the equipment is restored to good repair and properly operational.

F. Mulching

Mulch shall be spread uniformly over all seeded areas at a rate of 1 ½ to 2 tons per acre in a continuous, uniform blanket. Mulch shall be spread by hand or by approved mechanical shredder or blower which will provide a uniform blanket. An acceptable application shall be one that completely covers the ground but still allows some sunlight to penetrate and air to circulate while providing effective soil moisture conservation and reduced erosion. Mulching operation shall be pursued immediately following final seedbed preparation.

Tack or other approved binding material shall be applied over top of mulch in all necessary areas to ensure mulch will be held in place during adverse conditions. The rate and method of application shall be completed as directed by the Engineer.

The Contractor shall implement sufficient precautions to prevent mulch from entering drainage structures through displacement by wind, water or other causes. The Contractor shall remove completely any blockage to drainage structures, which may occur.

G. Maintenance

Grassed areas shall be accepted when a 95% cover of permanent grasses is achieved and weeds are not the dominant foliage. The Contractor shall keep all grassed areas in good condition, reseeding and mowing if and when necessary as directed by the Engineer. A good lawn shall be established over the entire project area and shall be maintained by the Contractor in an approved manner and kept in an approved condition until final acceptance.

The Contractor shall protect against washouts on slopes and ditch sections by a manner approved by the Engineer. Any damage or failure due to any cause shall be corrected by being either repaired or completely redone as may be directed by the Engineer. Areas of damage or failure resulting either from negligence on the part of the Contractor in performing construction operations or from not taking sufficient precautions to control erosion and silt as required throughout the various sections of the specifications, shall be repaired by the Contractor as directed by the Engineer at no cost to the Owner.

End of Section

Engineering Department
Manual Of
Practice



Life. Well Crafted.

600 Sewer System



CITY OF HICKORY

GENERAL NOTES FOR
SEWER SYSTEM

SHEET 1 OF 1

DATE:
2-1-07

STD. NO.
601

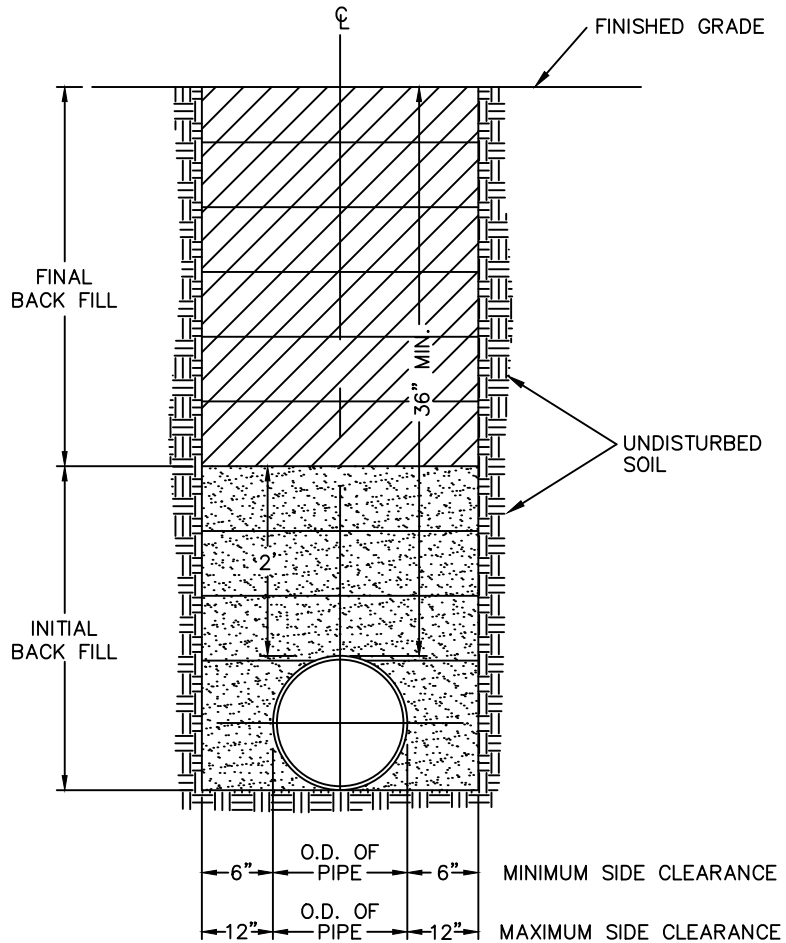

TYPICAL TRENCH BOTTOM DIMENSIONS FOR:
DUCTILE IRON, PVC, AND CONCRETE PIPE

TRENCH DETAIL
CLASS D FLAT SUBGRADE

NOTES:

1. TRENCHES REQUIRING SHORING AND BRACING, DIMENSIONS SHALL BE TAKEN FROM THE INSIDE FACE OF THE SHORING AND BRACING.
2. NO ROCKS OR BOULDERS 2" OR LARGER TO BE USED IN INITIAL BACKFILL.
3. ALL BACKFILL MATERIAL SHALL BE SUITABLE MATERIAL.
4. BACKFILL SHALL BE COMPACTED IN 6" LAYERS IN TRAFFIC AREAS, 12" LAYERS IN NON-TRAFFIC AREAS USING VIBRATORY EQUIPMENT.
5. ALL BACKFILL TO A HEIGHT OF 12" OVER PIPE TO BE COMPACTED BY MANUAL MEASURES.

DEPTH OF BEDDING
MATERIAL BELOW PIPE

D	d (MIN.)
27" & SMALLER	6"
30" - 60"	12"
66" & LARGER	18"

NOT TO SCALE



CITY OF HICKORY

SEWER LINE TRENCH BOTTOM DIMENSIONS
AND BACKFILLING REQUIREMENTS

SHEET 1 OF 1

DATE:
2-1-07

STD. NO.
602

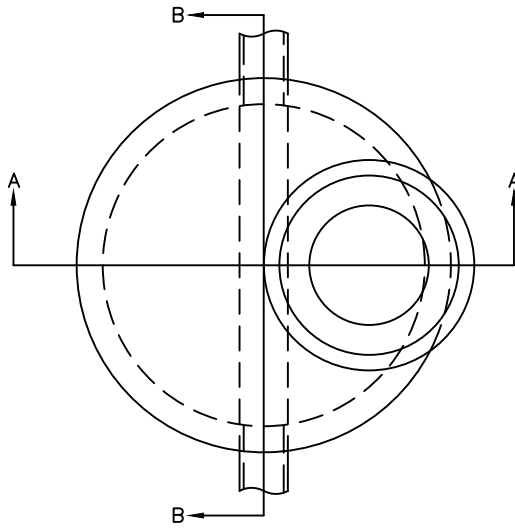

PLAN VIEW

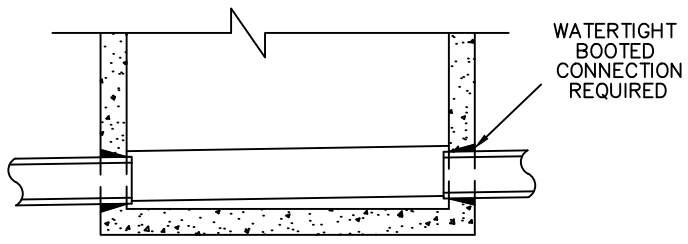

SECTION B-B

NOTES:

1. ON NEW INSTALLATION, A MAXIMUM OF 2 GRADE RINGS SHALL BE USED.
2. CONCRETE SHALL BE 4000 PSI AS PER ASTM C-478.
3. STEEL REINFORCING SHALL MEET ASTM A-305, A-15, A-160 OR LATEST STANDARD
4. MANHOLES OVER 3'-6" IN DEPTH SHALL BE PROVIDED WITH STEPS 1'-3" ON CENTER. STEPS SHALL BE IN ACCORDANCE WITH STANDARD NO. 603.
5. INVERT SHALL HAVE 0.20' OF FALL UNLESS OTHERWISE SPECIFIED.

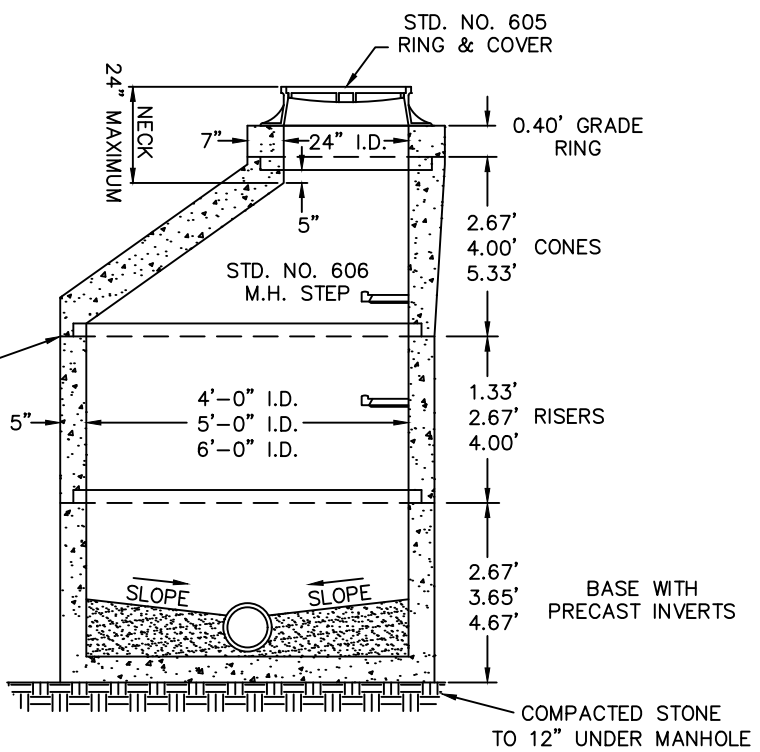

SECTION A-A

MANHOLE DIAMETER VS. PIPE DIAMETER

- 4'-0" = 27" PIPE MAXIMUM
- 5'-0" = 36" PIPE MAXIMUM
- 6'-0" = ABOVE 36" PIPE

NOT TO SCALE



CITY OF HICKORY		SHEET 1 OF 1
SANITARY SEWER MANHOLE DETAIL		DATE: 2-1-07
		STD. NO. 603

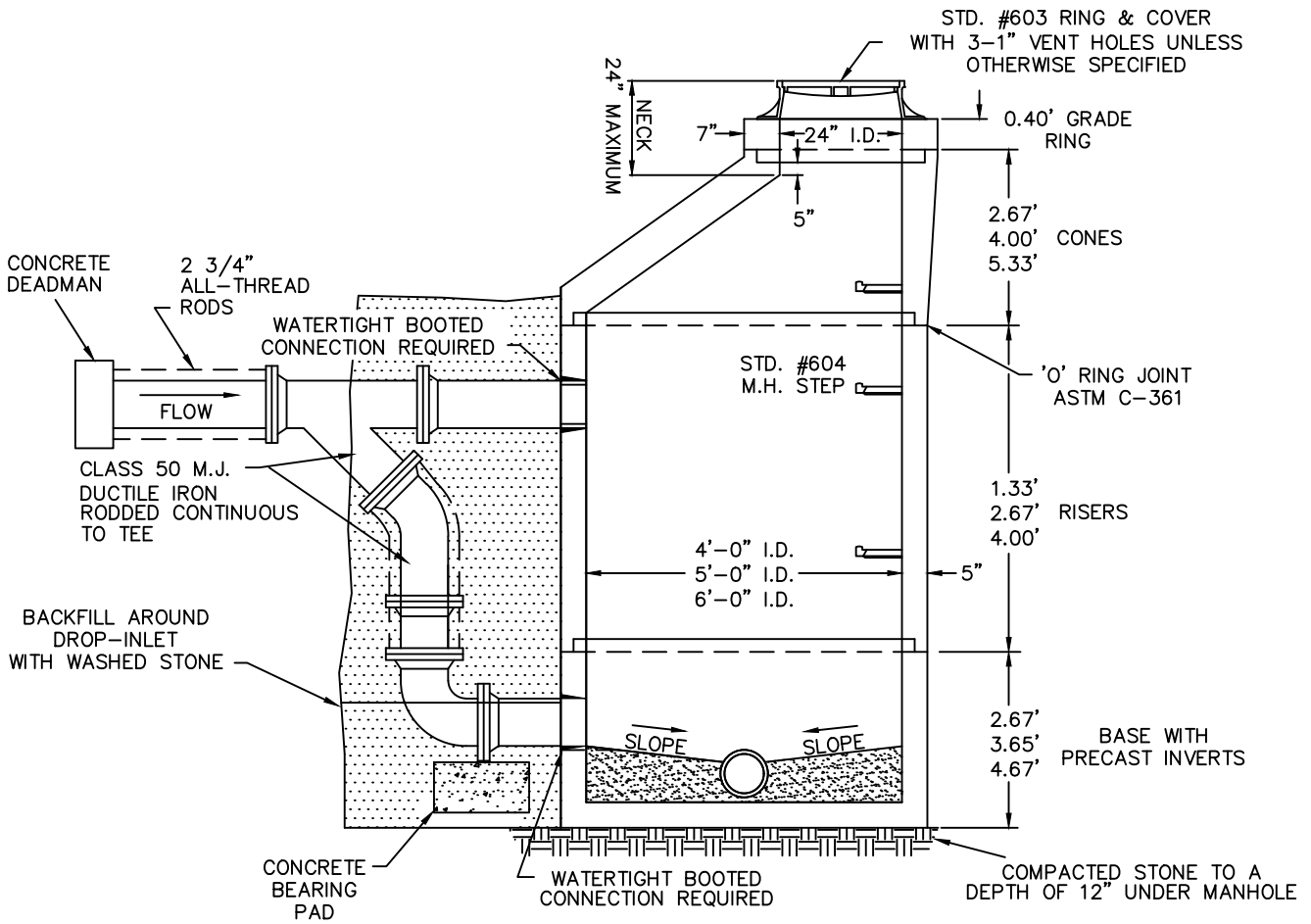

SANITARY SEWER DROP MANHOLE DETAIL

NOTES:

1. ON NEW INSTALLATION, A MAXIMUM OF 2 GRADE RINGS SHALL BE USED.
2. CONCRETE SHALL BE 4000 PSI AS PER ASTM C-478.
3. STEEL REINFORCING SHALL MEET ASTM C-185 FOR 4' DIAMETER, OR ASTM C-478 FOR 5' DIAMETER.
4. MANHOLES OVER 3'-6" IN DEPTH SHALL BE PROVIDED WITH STEPS 1'-3" ON CENTER. STEPS SHALL BE IN ACCORDANCE WITH STANDARD NO. 603.
5. INVERT SHALL HAVE 0.20' OF FALL UNLESS OTHERWISE SPECIFIED.

MANHOLE DIAMETER VS. PIPE DIAMETER

- 4'-0" = 27" PIPE MAXIMUM
- 5'-0" = 36" PIPE MAXIMUM
- 6'-0" = ABOVE 36" PIPE

NOT TO SCALE



CITY OF HICKORY

SANITARY SEWER
DROP MANHOLE

SHEET 1 OF 1

DATE:
2-1-07

STD. NO.
604

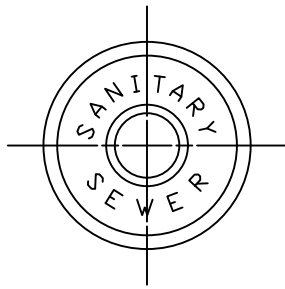

*ALL MANHOLE COVERS SHALL MEET
ASTM A48-94 OR LATEST STANDARD

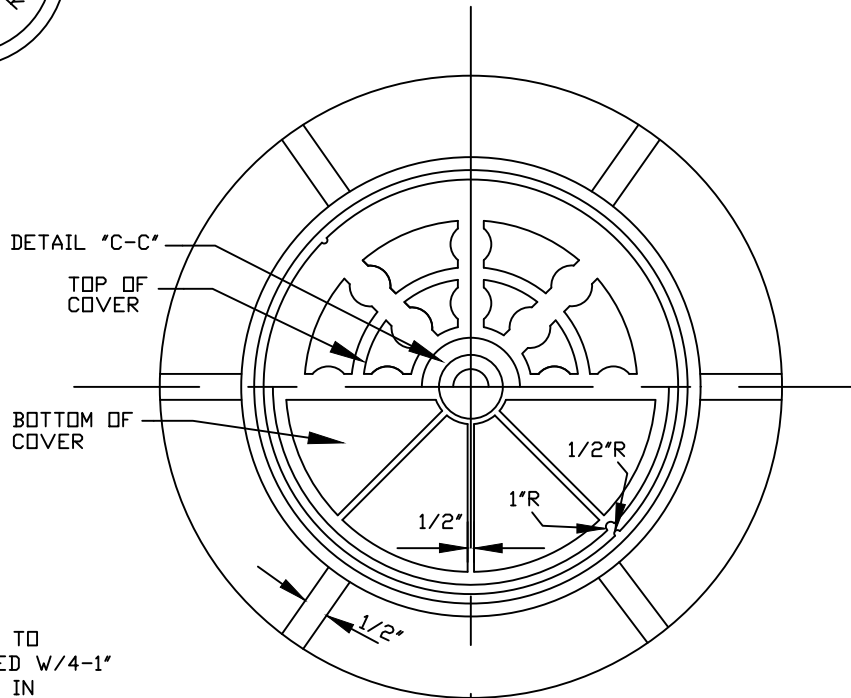

STND	
MIN. AVE. WTS.	
RING	190
COVER	125
	315
SHORT	
MIN. AVE. WTS.	
RING	150
COVER	130
	280

NOTES

1. ALL COVERS TO BE SUPPORTED W/4-1" VENT HOLES IN COVER
2. ALL RINGS TO BE SUPPORTED W/4-1" DIA. ANCHOR HOLES.
3. RING & COVER TO BE USF 669/KL OR EQUAL
4. SHORT R&C TO BE USF 686/KM OR EQUAL
5. BOLT DOWN/ WATER TIGHT R&C TO BE USF 668-KL-BWT OR EQUAL

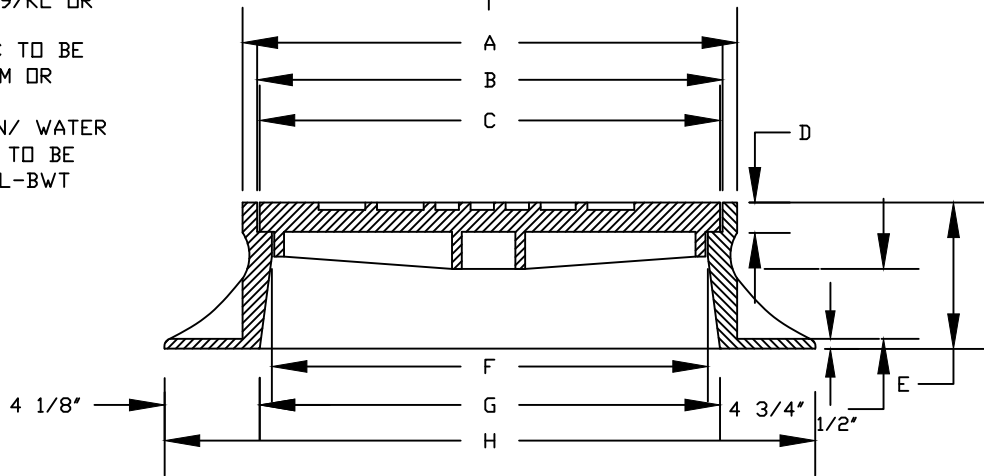

	A	B	C	D	E	F	G	H
STND	25 ¹ / ₄	23 ³ / ₄	23 ¹ / ₂	1"	7 ¹ / ₂	22"	25"	33 ¹ / ₄
SHORT	25"	23 ¹ / ₂	23 ¹ / ₄	1"	4"	22 ¹ / ₈	23 ¹ / ₈	33 ¹ / ₄

NOT TO SCALE



CITY OF HICKORY

STANDARD & SHORT
MANHOLE RING & COVER

SHEET 1 OF 1

DATE:
2-1-07

STD. NO.
605

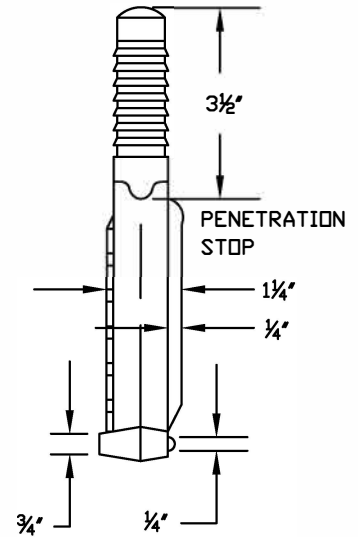
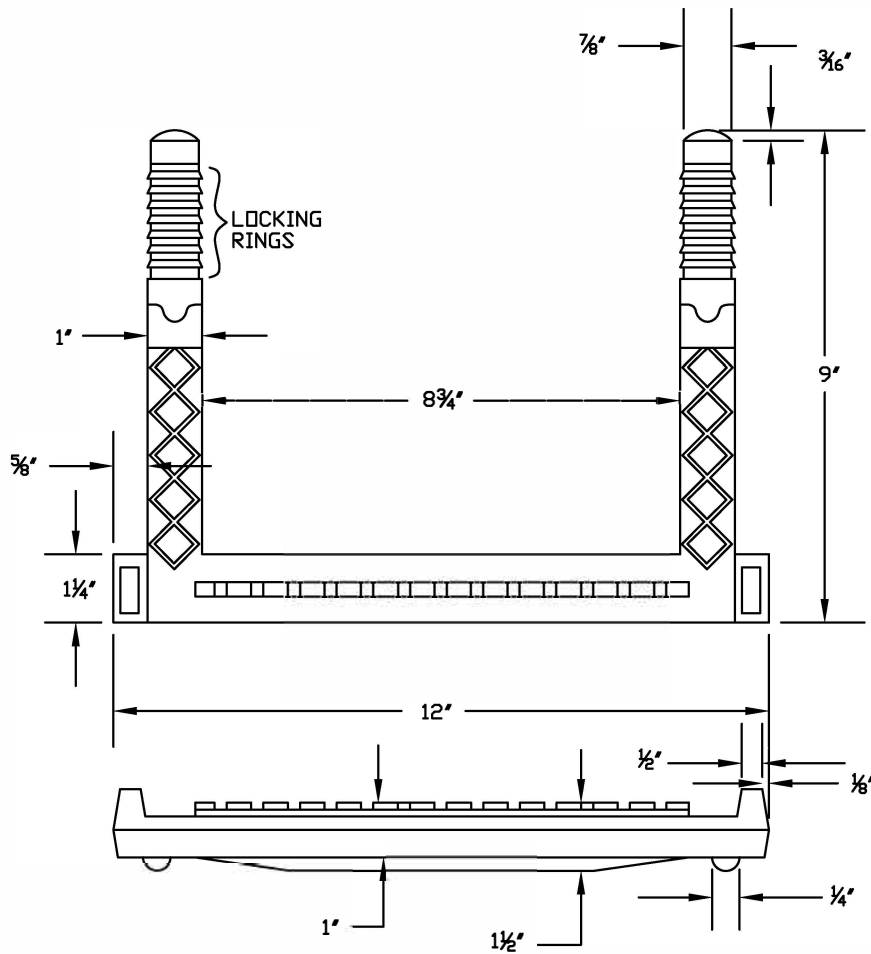

NOTES:

1. STEPS TO BE EPOXY GROUTED IN PLACE.
2. CENTERLINE OF THREAD TO BE LEVEL & PLUMB W/ ALL IN MH SECTION
3. MANHOLES AND OTHER STORM DRAIN STRUCTURES OVER 3' 6" IN DEPTH SHALL BE PROVIDED WITH STEPS 1' 3" ON CENTER

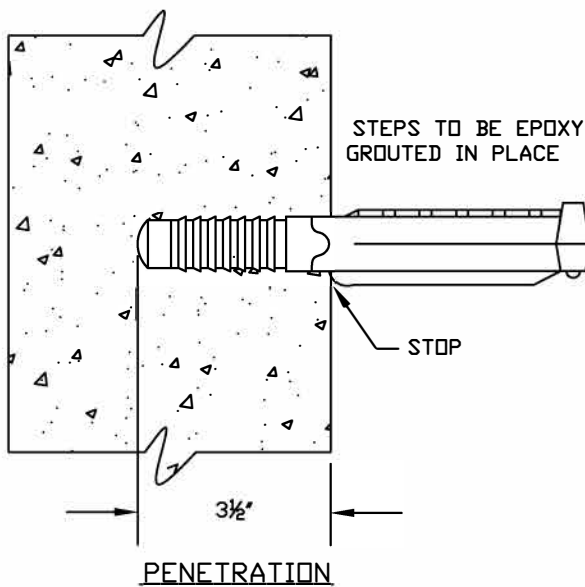

COPOLYMER
POLYPROPYLENE
PLASTIC

3 DEFORMED
STEEL ROD

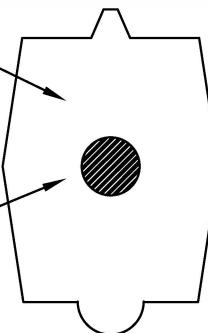

SECTION A-A

NOT TO SCALE



CITY OF HICKORY

MANHOLE STEP FOR PRECAST
CONCRETE MANHOLE

SHEET 1 OF 1

DATE:
2-1-07

STD. NO.
606

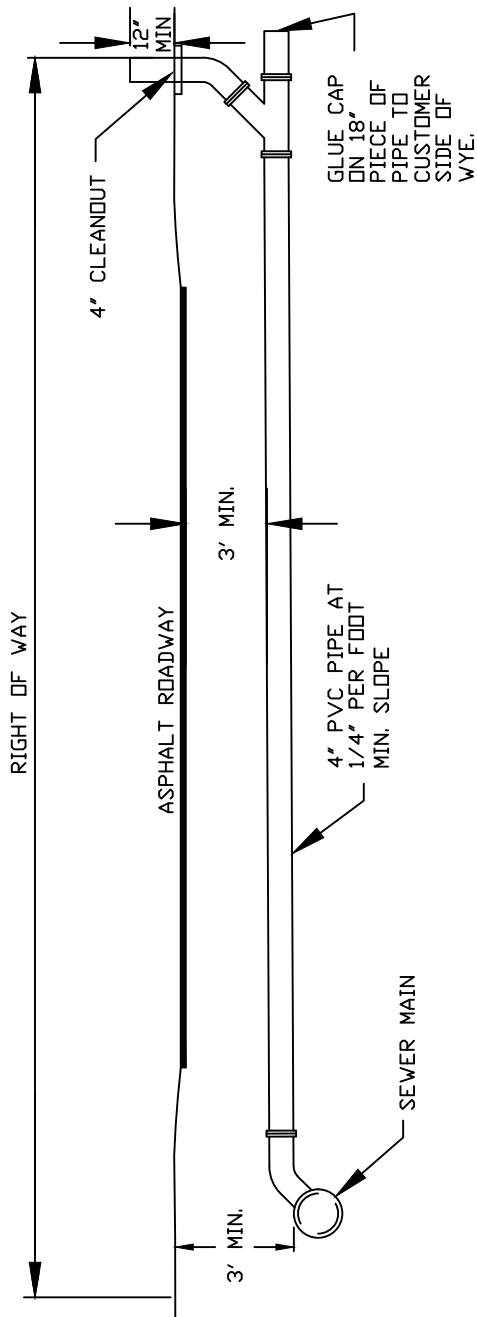

- NOTE:
1. 4" CLEANDOUT TO REMAIN VISIBLE
 2. PLUMBER SHALL CONNECT TO 4" LINE BY REMOVING GLUE CAP AND COUPLING PIPE TOGETHER; IN NO CASE SHOULD PLUMBER TIE TO CITY CLEANDOUT.

NOT TO SCALE



CITY OF HICKORY

RESIDENTIAL SEWER TAP

SHEET 1 OF 1

DATE:
2-1-07

STD. NO.
607

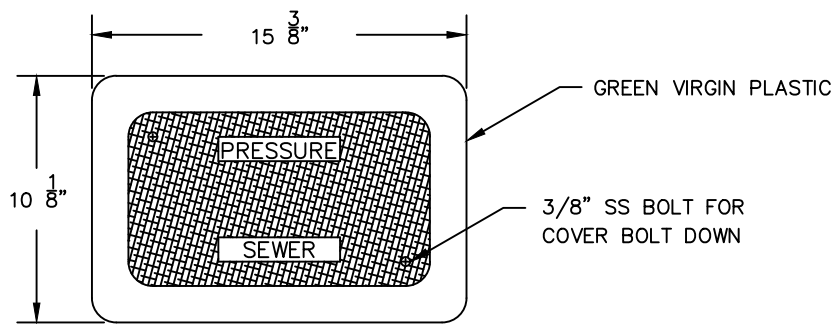
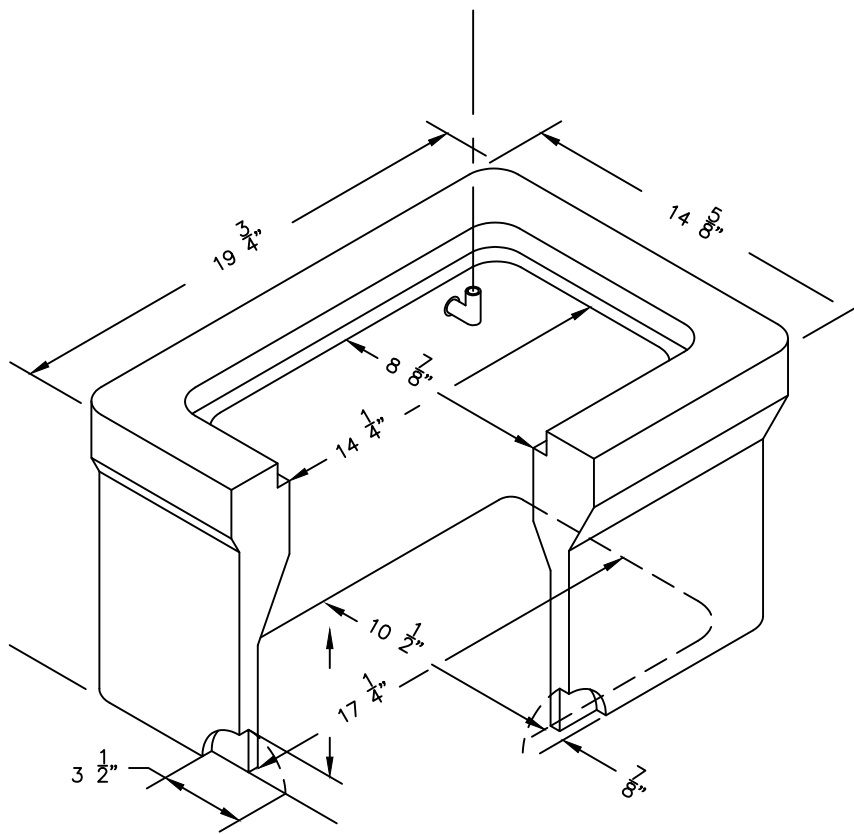

NOT TO SCALE



CITY OF HICKORY

LOW PRESSURE SEWER
CLEANOUT BOX

SHEET 1 OF 1

DATE:
2-1-07

STD. NO.
608

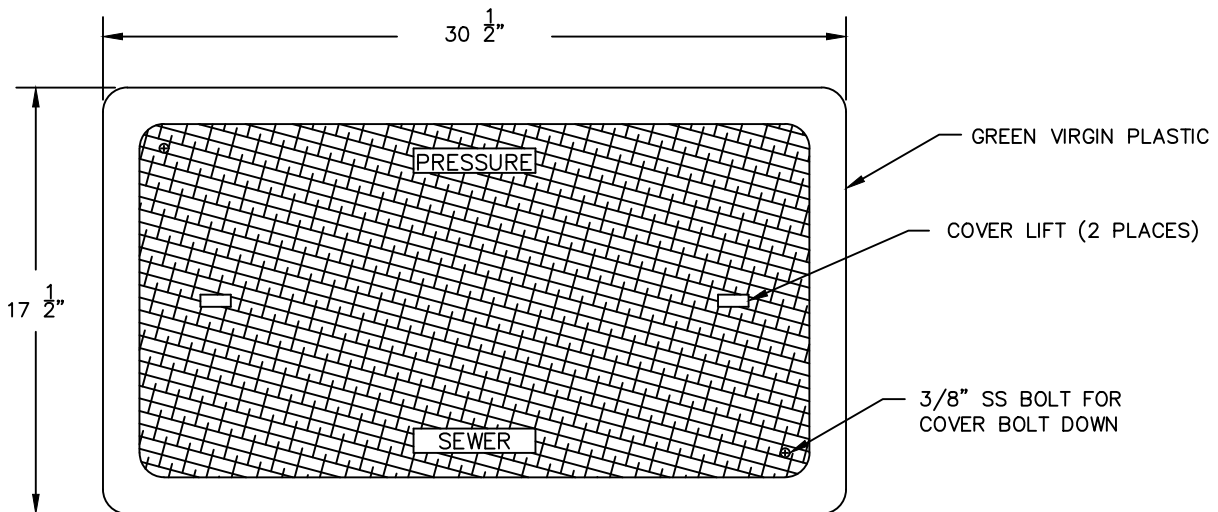
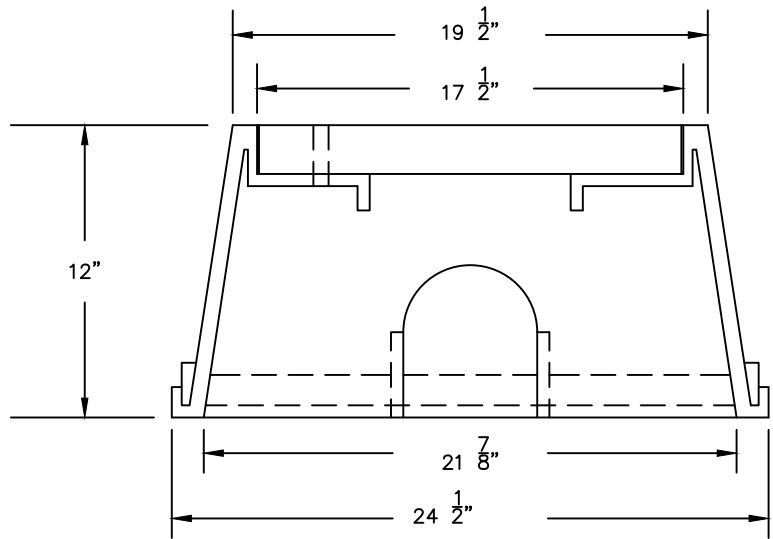
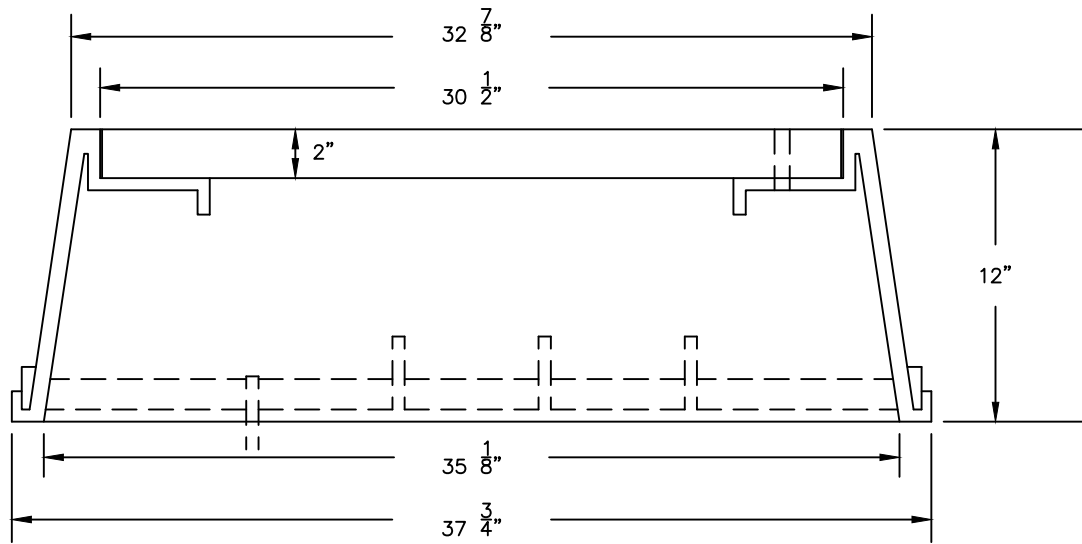

NOT TO SCALE



CITY OF HICKORY

LOW PRESSURE SEWER
SERVICE BOX

SHEET 1 OF 1

DATE:
2-1-07

STD. NO.
609

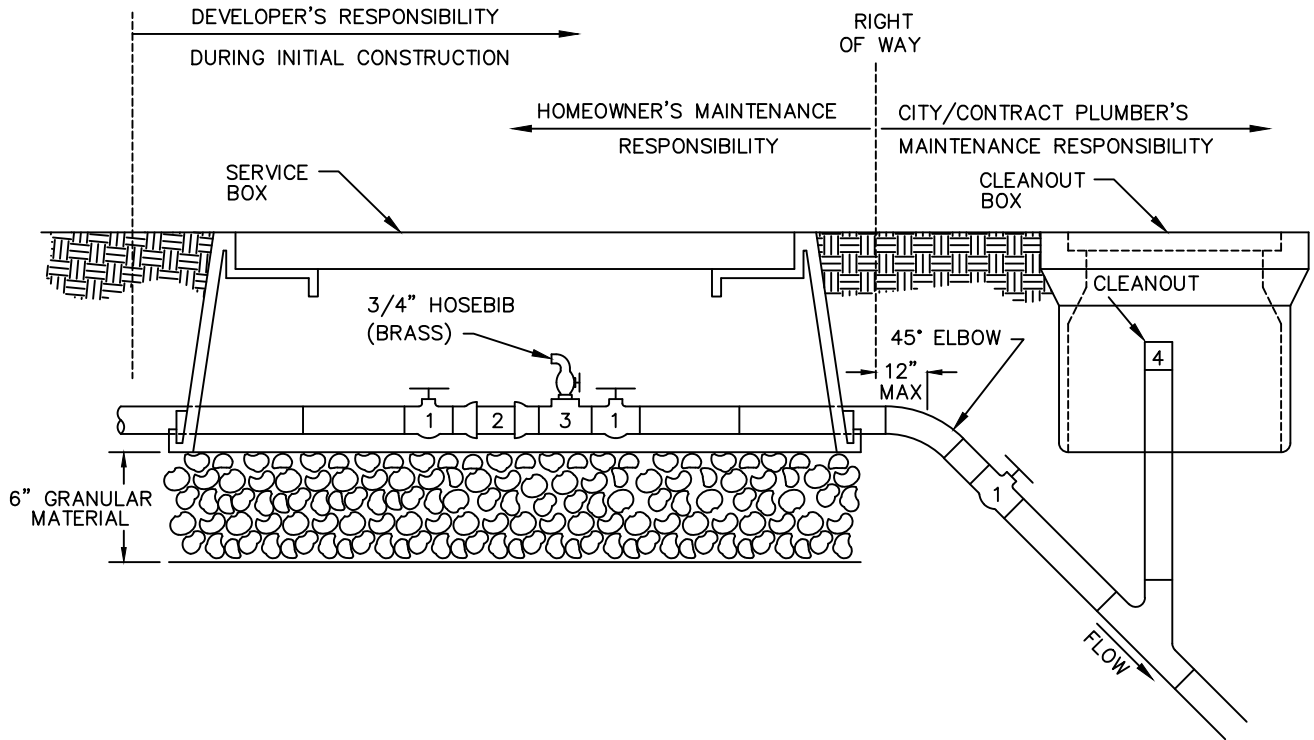

LEGEND:

- 1. 1 1/2" TRUE UNION BALL VALVE
- 2. 1 1/2" TRUE UNION BALL CHECK VALVE
- 3. 1 1/2" THREADED "T" WITH 1 1/2"x3/4" THREADED REDUCING BUSHING
- 4. 3/4" AIR LINE QUICK CONNECT FITTING.

NOTES:

- 1. BOXES SHALL NOT BE IN SIDEWALKS OR DRIVEWAYS.
- 2. TOP OF BOXES SHALL BE FLUSH WITH THE FINISH GRADE.

NOT TO SCALE



CITY OF HICKORY

LOW PRESSURE SEWER
SERVICE CONNECTION

SHEET 1 OF 1

DATE:
2-1-07

STD. NO.
610

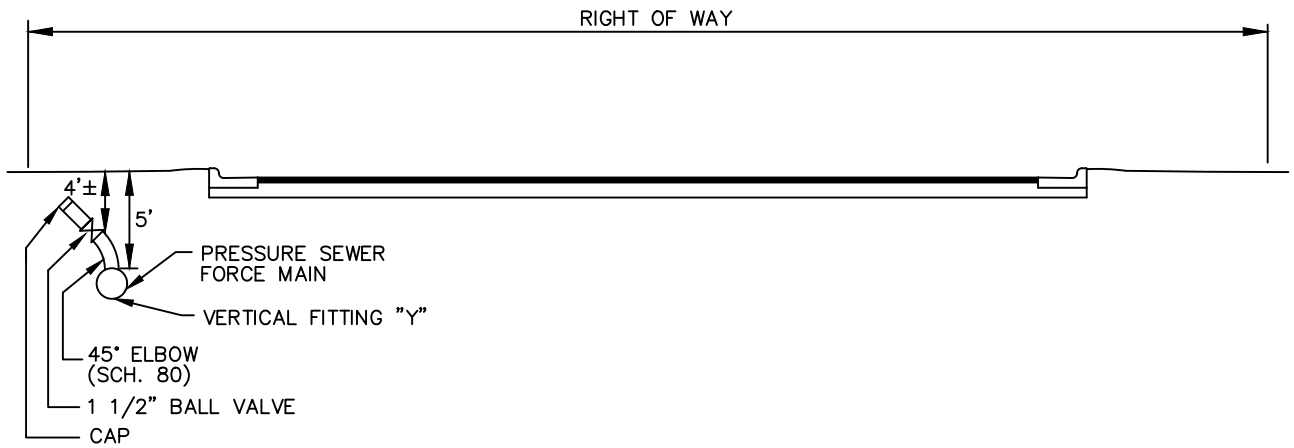

SHORT SIDE PARTIAL LATERAL SERVICE

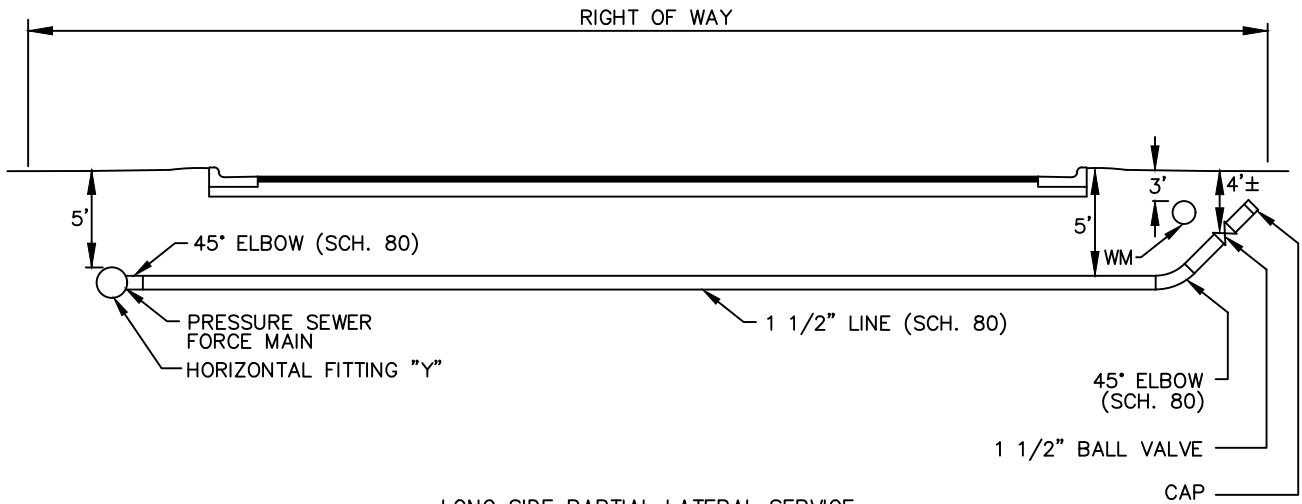

LONG SIDE PARTIAL LATERAL SERVICE

NOTE:

1. A PVC ENCAPSULATED MAGNET SHALL BE ATTACHED TO THE VALVE FOR MAGNETIC LOCATION PURPOSES.

NOT TO SCALE



CITY OF HICKORY

LOW PRESSURE SEWER
PARTIAL LATERAL SERVICE

SHEET 1 OF 1

DATE:
2-1-07

STD. NO.
611

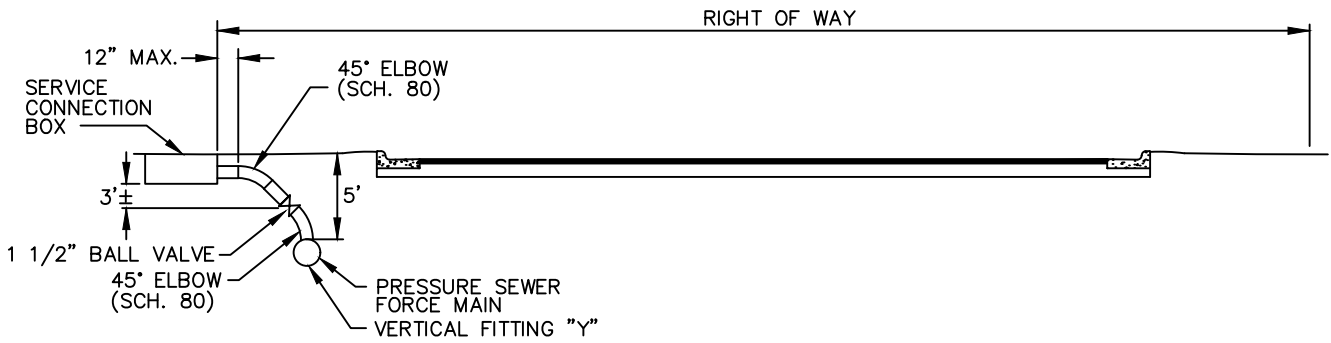

SHORT SIDE LATERAL SERVICE

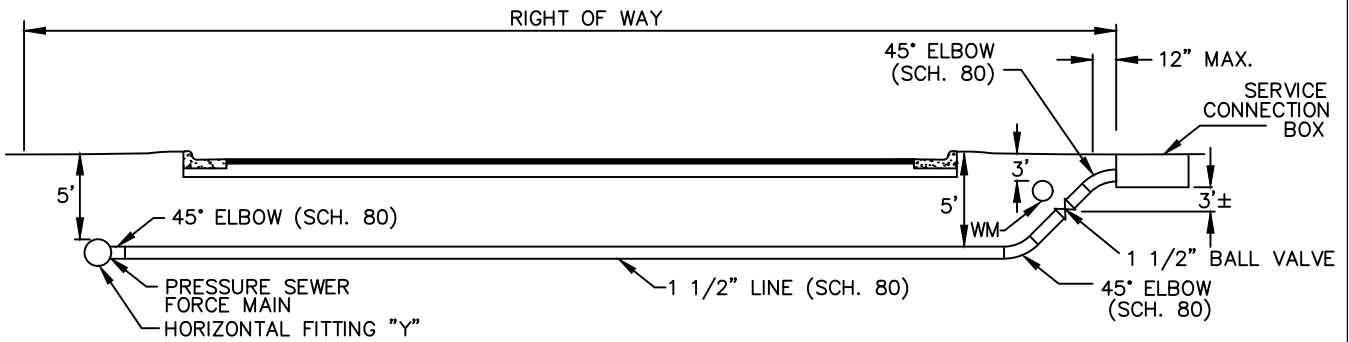

LONG SIDE LATERAL SERVICE

NOT TO SCALE



CITY OF HICKORY

LOW PRESSURE SEWER
LATERAL SERVICE

DATE:
2-1-07

SHEET 1 OF 1
STD. NO.
612

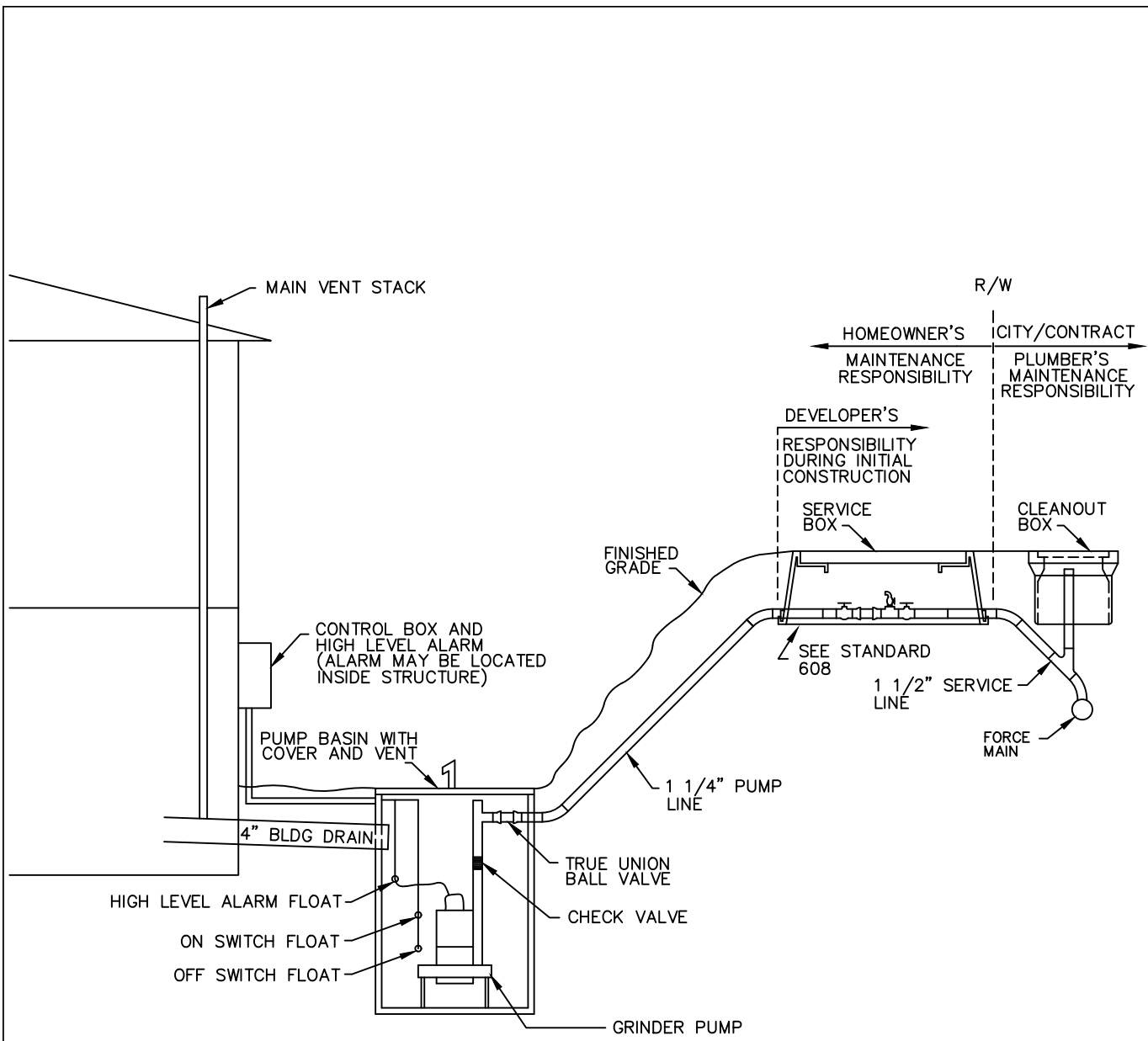

NOTES:
 SEE ALSO CITY OF HICKORY STANDARD
 SANITARY SEWER SPECIFICATIONS. IN
 THE EVENT OF A CONFLICT BETWEEN THE
 DRAWINGS AND SPECIFICATIONS, THE MORE
 STRINGENT SHALL APPLY.

NOT TO SCALE



CITY OF HICKORY

LOW PRESSURE SEWER
 INDIVIDUAL SYSTEM

SHEET 1 OF 1

DATE:
 2-1-07

STD. NO.
 613

NOTES

1. ONLY ONE INSIDE DROP CONNECTION PER MANHOLE WILL BE ALLOWED UNLESS OTHERWISE INDICATED ON THE DRAWINGS.
2. THE DROP BOWL SHALL NOT EXTEND INTO THE AREA AS DEFINED BY THE PROJECTION OF THE MANHOLE ENTRANCE VERTICALLY DOWN TO THE MANHOLE BOTTOM. IF NECESSARY, MANHOLE FRAME, COVER CONE SECTION, AND STEPS SHALL BE REMOVED AND PLACED TO ALLOW FOR UNOBSTRUCTED ENTRY AND EXIT.
3. INFLUENT PIPE SLOPE SHALL NOT EXCEED 10%.
4. MAXIMUM SIZE OF INFLUENT PIPE IS 12".

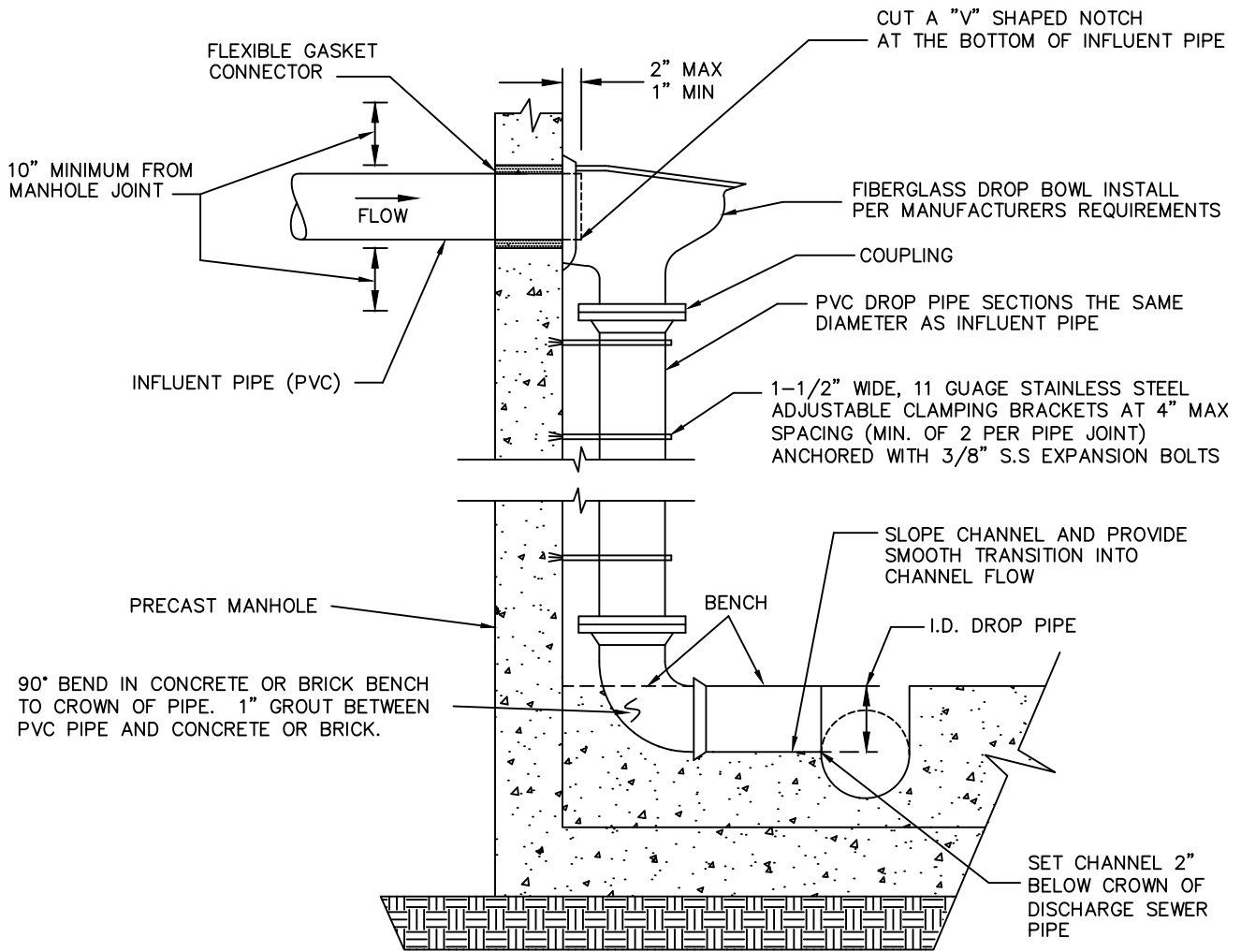

INSIDE DROP CONNECTION FOR
PRECAST CONCRETE MANHOLES
(FIBERGLASS DROP BOWL)

NOT TO SCALE



CITY OF HICKORY

INSIDE DROP CONNECTION
FOR PRECAST CONCRETE MANHOLE
(FIBERGLASS DROP BOWL)

SHEET 1 OF 1

DATE:
2-1-07

STD. NO.
614

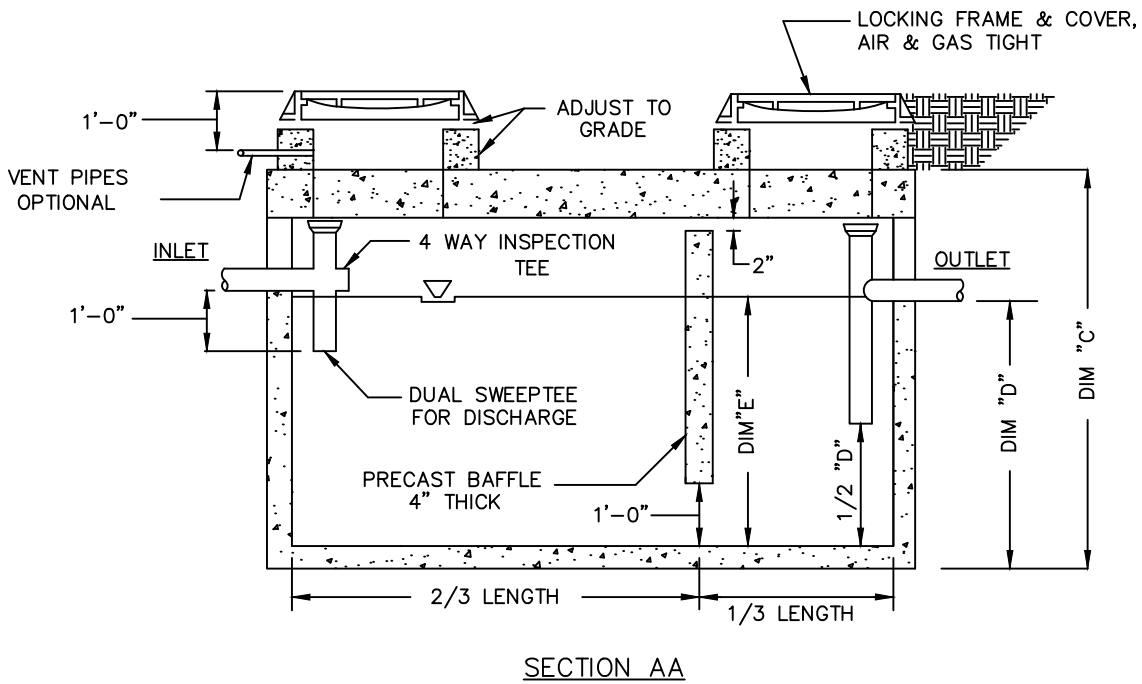
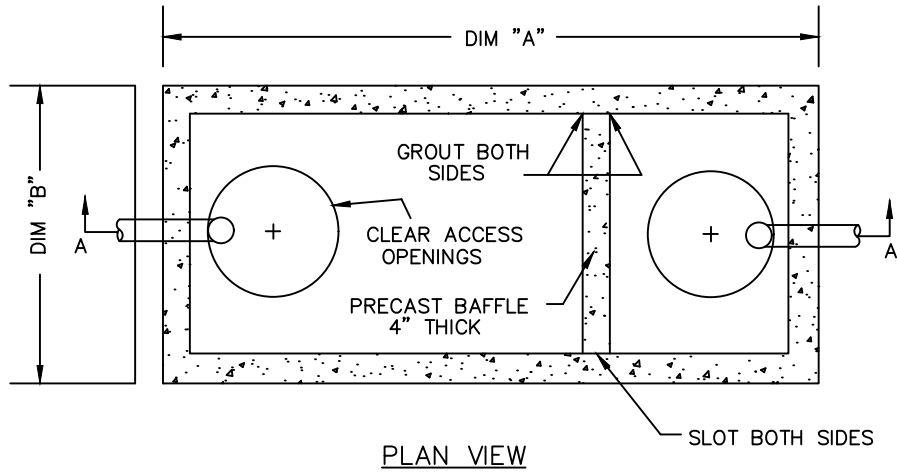

NOT TO SCALE



CITY OF HICKORY

TYPICAL GREASE TRAP
DETAIL

SHEET 1 OF 2

DATE:
2-1-07

STD. NO.
615

SIZING CHART					
GALLON CAPACITY	DIM"A"	DIM"B"	DIM"C"	DIM"D"	DIM"E"
600	7' - 0"	4' - 8"	7' - 0"	3' - 6"	3' - 2"
750	7' - 0"	4' - 8"	7' - 0"	4' - 3"	3' - 11"
1000	7' - 0"	5' - 0"	7' - 2"	4' - 2"	3' - 10"
1250	9' - 0"	5' - 0"	7' - 2"	5' - 2"	4' - 10"
1500	9' - 0"	5' - 8"	7' - 2"	4' - 4"	4' - 0"
1750	11' - 2"	5' - 8"	7' - 2"	4' - 11"	4' - 7"
2000	11' - 2"	6' - 8"	8' - 0"	4' - 7"	3' - 10"
2500	12' - 8"	6' - 8"	8' - 0"	5' - 6"	4' - 9"
2750	12' - 8"	6' - 8"	8' - 0"	6' - 0"	5' - 3"
3000	15' - 7"	9' - 7"	8' - 6.5"	6' - 3"	3' - 9"
4000	15' - 7"	9' - 7"	8' - 6.5"	6' - 3"	5' - 0"
5000	19' - 11"	9' - 11"	8' - 11"	6' - 2"	4' - 9"
6000	19' - 11"	9' - 11"	10' - 5"	7' - 2"	5' - 9"

NOTES

1. CONCRETE: 28 DAYS f c = 4500psi
2. REBAR: ASTM A515 GRADE 60
3. MESH: ASTM A-155 GRADE 65
4. DESIGN: ACI318-83 BUILDING CODE
ASTM C-857 MINIMUM STRUCTURAL DESIGN
LOADING FOR UNDERGROUND PRECAST
CONCRETE UTILITY STRUCTURES
5. LOADS: H-20 TRUCK WHEELS W/30% IMPACT PER AASHTO
6. FILL W/ CLEAN WATER PRIOR TO START UP OF SYSTEM
7. CONTRACTOR TO SUPPLY AND INSTALL ALL PIPING
AND SANITARY TEES, 4 CLEAN OUTS, FOR CLEANING
TOWARD TRAP AND FOR CLEANING AWAY FROM TRAP
ON BOTH THE INLET AND OUTLET/ ALT, DUAL SWEEP
CLEANOUTS.
8. GRAY WATER ONLY, BLACK WATER SHALL BE CARRIED
BY SEPERATE SEWER.
9. EFFLUENT FILTER REQUIRED: ZABEL A300-12 OR EQUAL

NOT TO SCALE



CITY OF HICKORY

TYPICAL GREASE TRAP
DETAIL

SHEET 2 OF 2

DATE:
2-1-07

STD. NO.
615

4" ASPHALT SURFACE
TYPE S9.5C IN 2" LIFTS

12" COMPACTED AGGREGATE
BASE COARSE

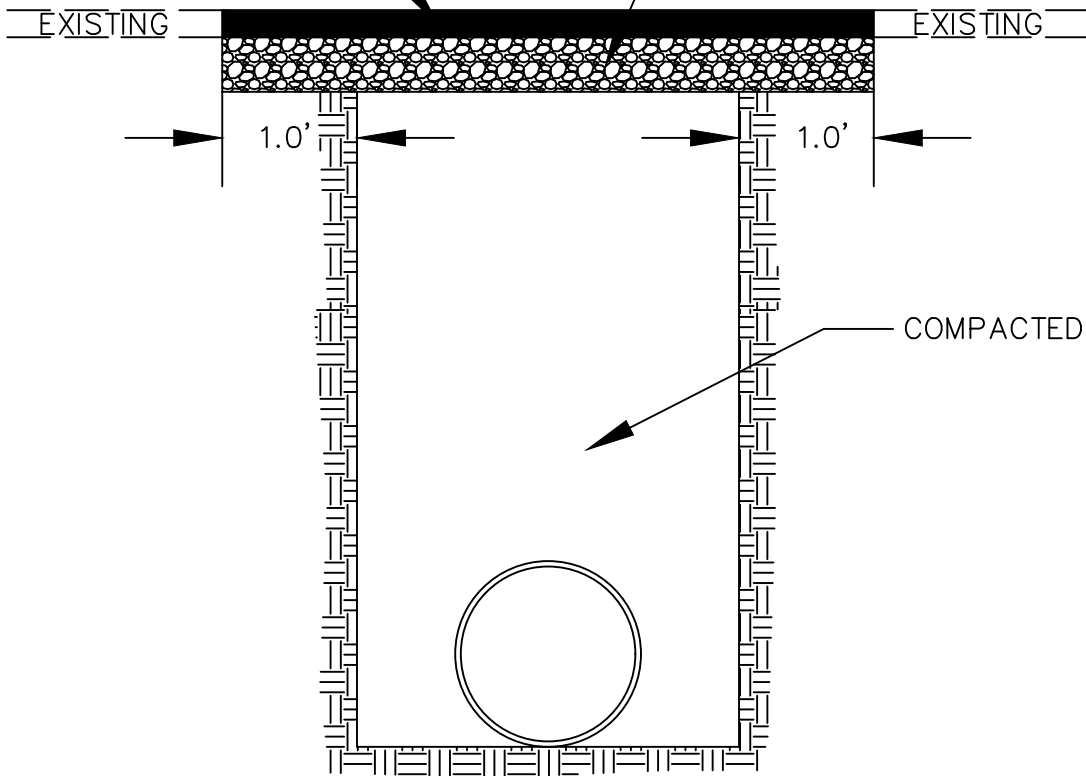

NOT TO SCALE



CITY OF HICKORY

ROAD PATCH AND REPAIR

SHEET 1 OF 1

DATE:
9-30-22

STD. NO.
616

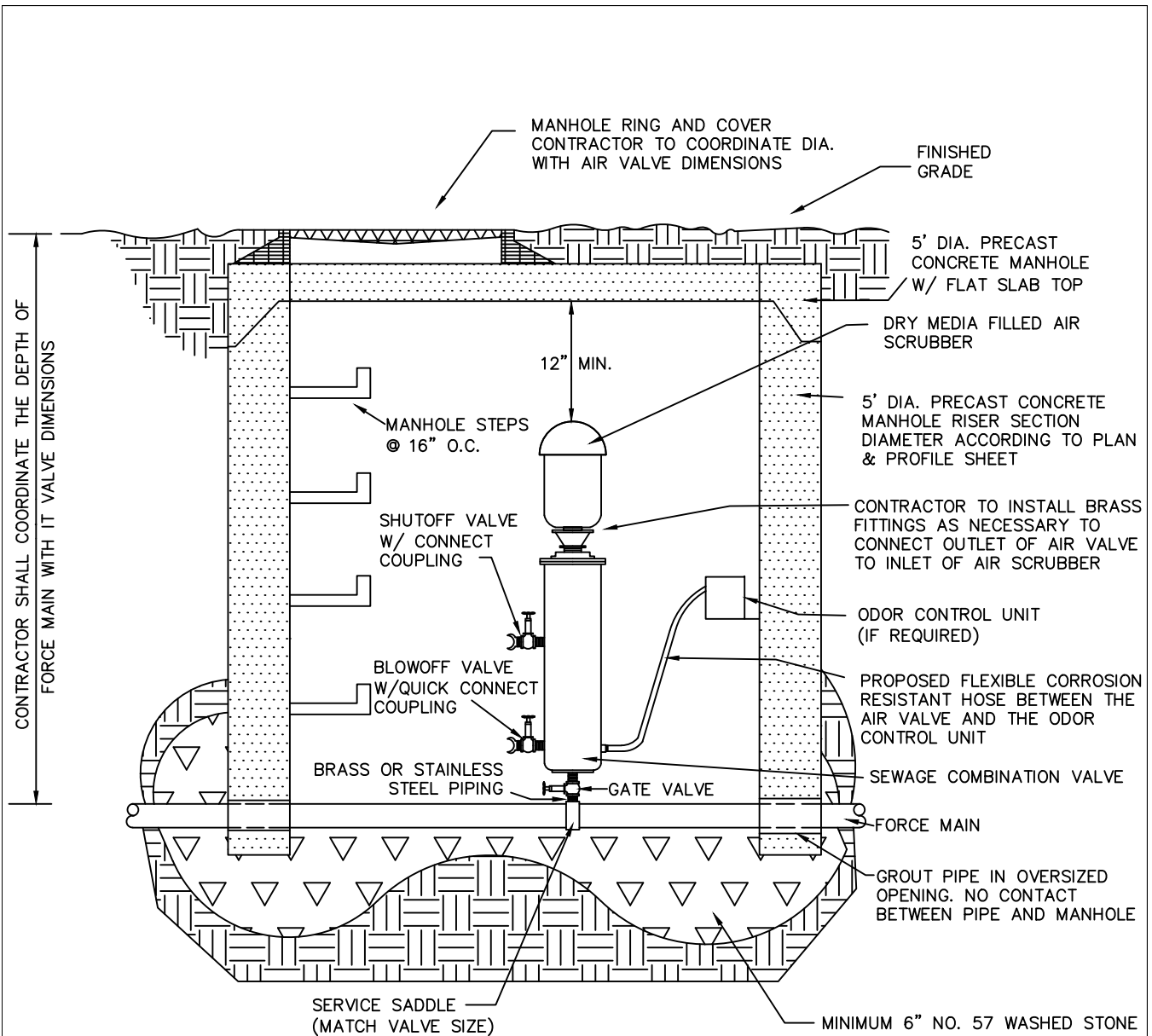

NOTES:

1. COMBINATION AIR VALVE TO BE INSTALLED AT ACTUAL HIGH POINT OF LINE.
2. COMBINATION AIR VALVE SHALL BE OFFSET IN MANHOLE TO PROVIDE ACCESS.
3. VALVE SIZE AS SHOWN ON DRAWINGS OR DETAILED IN THE SPECIFICATIONS.
4. ALL PIPING AND FITTINGS FOR COMBINATION AIR VALVE SHALL BE BRASS OR STAINLESS STEEL
5. CONTRACTOR SHALL ADJUST THE DEPTH OF THE FORCE MAIN AT ALL HIGH POINTS TO ACCOMMODATE THE INSTALLATION OF THE COMBINATION AIR VALVE.
6. CONTRACTOR SHALL INSTALL ODOR CONTROL UNIT AS DIRECTED BY ENGINEER OR CITY OF HICKORY.

NOT TO SCALE

CITY OF HICKORY

SEWAGE FORCE MAIN COMBINATION AIR VALVE

SHEET 1 OF 1

DATE:
5-27-21

STD. NO.
617

Engineering Department
Manual Of
Practice



Life. Well Crafted.

Sewer Specifications

SECTION 022000 - EARTHWORK

PART 1 – GENERAL

1.01 SECTION INCLUDES

- A. Installation, protection and/or modification of utilities during site work construction, including any necessary staging of work.
- B. Scarifying, compaction and testing of previously graded sites to ensure proper preparation and acceptability.
- C. Excavation and embankment placement to required lines, dimensions, and subgrade elevations.
- D. Preparation of existing low areas for placing of fill, including disposal of muck, topsoil, silt and wet or unsuitable materials.
- E. SUB-SURFACE DATA:
 - 1. Investigation: Sub-surface investigations tilted Geotechnical Investigation proposed Hickory Center, Hickory, NC Project No. 90G-010100.6, dated September 18, 1990 have been made. A copy of this report can be found at the back of this specification. The report is furnished as a mater of convenience and courtesy and there is no implied or expressed warranty as to the correctness of the report as to the existing condition. However, where a treatment is not covered in the specification, the recommendations made in the report shall be considered binding.
 - 2. Site Visit: Data shown is for general information for bidders. Contractors are expected to examine the site, make investigations and decide for themselves the character of the materials to be encountered.
 - 3. Responsibility: The owner will not assume responsibility for variations of sub-soil quality or condition.

1.02 REFERENCE STANDARDS

The following most current publications form part of this specification to the extent indicated by references thereto and shall be followed for all construction testing.

Section 02200-1

American Society for Testing and Materials (ASTM):

- D 422 Method for Partial Size Analysis of Soils
- D 698 Test for Moisture-Density Relations of Soils using 5.5 lb. (2.5 kg) Rammer and 12-inch (304.8mm) Drop (Standard Proctor)
- D 1556 Test for Density of Soil in Place by Sand Cone Method
- D 1557 Test for Moisture-Density Relations Using 10-lb (4.5 kg) Rammer and 18-inch (457mm) Drop (Modified Proctor)
- D 1559 Test Method for Resistance to Plastic Flow of Bituminous Mixtures Using Marshall Apparatus
- D 2167 Test for Density of Soil in Place by the Rubber Balloon Method
- D 2216 Laboratory Determination of Moisture Content of Soil
- D 2487 Classification of Soils for Engineering Purposes
- D 2922 Tests for Density of Soil and Soil-Aggregate in Place by Nuclear Methods (Shallow Depth)
- D 3017 Test for Moisture Content of Soil and Soil-Aggregates by Nuclear Methods (Shallow Depth)
- D 4318 Test for Plastic Limit, Liquid Limit & Plasticity Index of Soils
- C 25 Chemical Analysis of Limestone, Quicklime and Hydrated Lime
- C 110 Physical Testing of Quicklime and Hydrated Lime, Wet Sieve Method
- C 618 Specification for Fly Ash and Raw or Calcined Natural Pozzolan for Use as a Mineral Admixture in Portland cement Concrete
- C 977 Quicklime and Hydrated Lime for Soil Stabilization

American Association of State Highway and Transportation Officials (AASHTO)

- T 88 Mechanical Analysis of Soils

PART 2 PRODUCTS

2.01 MATERIALS

- A. Acceptable Stabilization Fabrics and Geogride:
 - 1. Mirafi 500X or 600X
 - 2. Phillips 66 Supac 6WS
 - 3. Dupont Typar 3401 and 3601
 - 4. Trevira S1114 and S1120
 - 5. Tensar SS-1 and SS-2
 - 6. Exxon GTF-200 or 350

- B. Filter/Drainage Fabrics:
 - 1. Mirafi 140NS
 - 2. Phillips 66 Supac 4NP
 - 3. Dupont Typar 3341

Section 02200-2

- C. Silt Fencing Fabrics:
 - 1. Phillips 66 Supac 5 NP (UV)
 - 2. Mirafi 100X
- D. Material for filling and backfilling shall be clean subsoil free from debris, roots, topsoil, frozen material and rock larger than ½ cu. ft. Fill materials shall be tested and approved by the laboratory for the degree of compaction required by its intended use.
- E. Unsuitable fill material shall be defined as that which fails to conform to requirements of paragraph 2.01 above.

PART 3 EXECUTION

3.01 PREPATATION

- A. Remove excess or unsuitable materials from the site at no additional cost to Owner. All excess and/or unsuitable material shall be wasted off site at allocation approved by the North Carolina Department of Natural Resources and Community Development (Erosion Control). Backfill areas with layers of material and compact as specified.
- B. Prior to placing fill in low areas, such as previously existing creeks, ponds or lakes perform following procedures:
 - 1. Drain water out by gravity with ditch having flow line lower than lowest elevation in low area. If drainage cannot be performed by gravity ditch, use adequate pump to obtain same results.
 - 2. After drainage of low area is complete, remove muck, mud, debris, and other unsuitable material by using acceptable equipment and methods that will keep natural underlying low areas dry and undisturbed.
 - 3. If proposed for fill, all muck, mud and other materials removed from above in low areas shall be dried on-site by spreading in thin layers for observation by Owner's representative. Material shall be inspected and, if found to be suitable for use as fill material shall be incorporated into lowest elevation of site filling operation, but not under or within 10'-0" of perimeter of building pad or paving subgrade. If, after observation by Owner's representative, material if found to be unsuitable material shall be removed from site at no additional cost to Owner.

Section 02200-3

4. Provide additional materials at no additional cost to Owner where existing materials are insufficient or unsuitable for their intended use. Borrow pits shall be approved by Owner's representative and the North Carolina Department of Natural Resources and Community Development (Erosion Control).

3.02 EXCAVATION FOR FILLING AND GRADING

- A. Classification of Excavation: Contractor by submitting bid acknowledges that he has investigated site to determine type, quality, quantity and character of excavation work to be performed. All excavation shall be considered unclassified excavation.
- B. Perform excavation using capable, well-maintained equipment and methods acceptable to Owner and governing agencies.
- C. When performing grading operations during periods of wet weather, provide adequate drainage and ground water management to control moisture of soils. Site dewatering is Earthwork Contractors responsibility at no additional cost to Owner.
- D. Shore, base and drain excavations as necessary to maintain safe, secure and free of water at all times.
- E. Perform rock excavation in a manner that will produce material of such size as to permit it being placed in embankments. Remove loose or shattered rock, overhanging ledges and boulders, which might dislodge.
- F. Use suitable material to replace rock overblast in building area and in expansion area to facilitate placement of utilities and future footings.
- G. Break or crush rock obtained from blasting to allow use for fill in parking area as follows:
 1. Rock 6" or greater in largest dimension is unacceptable as fill within proposed building and paving area.
 2. Rock less than 6" in largest dimension is acceptable as fill to within 24" of surface of proposed subgrade when mixed with suitable material.
 3. Rock fragments less than 2" in largest dimension and mixed with suitable material is acceptable as fill within the upper two feet (2') of proposed subgrade.

3.03 USE OF EXPLOSIVES

- A. Comply with all laws, rules and regulations of federal, state and local authorities and insure which govern storage, use, manufacture, sale, handling, transportation, licensing, or other disposition of explosives. Take special precautions for proper use of explosives to prevent harm to human life and damage to surface structures, all utility lines or other subsurface structures. Do not conduct blasting operations until persons in vicinity have had ample notice and have reached positions of safety.
- B. Contractor shall save harmless Owner, Architect and Owner's representative from any claim growing out of use of such explosives. Removal of materials of any nature by blasting shall be done in such manner and such time as to avoid damage affecting integrity of design and to avoid damage to any new or existing structure included in or adjacent to work. It shall be Contractors' responsibility to determine method of operation to ensure desired results and integrity of completed work.

3.04 FILLING AND SUBGRADE PREPARATION

A. BUILDING SUBGRADE AREAS:

1. Building subgrade pad shall be that portion of site directly beneath and ten feet (10') beyond the building and appurtenance limits.
2. The building subgrade pad shall be prepared in strict accordance with the "foundation subsurface preparation", to be provided by Owner.
3. Unless specifically indicated otherwise on the drawings, areas exposed by excavation or stripping and on which building subgrade preparations are to be performed shall be scarified to a minimum depth of 12" and compacted to a minimum of 98% of the optimum density, in accordance with ASTM D 698, at a moisture content of not less than 1% below and not more than 3% above the optimum moisture content.

These areas shall then be proof rolled to detect any areas of insufficient compaction. Proof rolling shall be accomplished by making a minimum of two (2) complete passes with a fully-loaded tandem-axle dump truck or approved equivalent, in each of the two perpendicular directions under the supervision and direction of a field geotechnical engineer. Areas of failure shall be excavated and replaced with suitable fill material per these specifications.

4. Unless specifically indicated otherwise on the drawing, fill materials used in preparation of building subgrade shall be placed in lifts or layers not to exceed 8" loose measure and compacted to a minimum density of 98% of optimum density, in accordance with ASTM D 698, at a moisture content of not less than 1% below and not more than 3% above the optimum moisture content. Unless specifically stated otherwise in the "foundation subsurface preparation" on the drawing.
5. The top 18" of building and parking subgrade shall be compacted to 100% Standard Proctor.

The following table stipulated maximum allowable values for Plasticity Index (PI) and Liquid Limit (LL) of suitable materials to be used as fill in the specified areas.

<u>Location:</u>	<u>PI</u>	<u>LL</u>
Building area, below upper four feet	20	50
Building area, upper four feet	12	40

B. SETTLEMENT MONITORING OF BUILDING SUBGRADE AREAS:

1. Settlement hubs are to be installed in the building areas in locations shown on the plans by the site grading contractor.
2. Settlement hubs shall be 8" in diameter and embedded a minimum of 30" into the subgrade at the building pad "blue top" elevation as detailed on the plans.
3. Settlement hub monitoring shall begin as soon as the building subgrade is reached. Monitoring shall be performed daily the first week of installation and weekly thereafter. Accuracy of monitoring is to be to 1/100 of a foot.
4. The on-site soils engineer shall monitor the settlement hubs. The site contractor shall insure that a stable bench mark is maintained at all times during monitoring and site work.
5. Reports of settlement monitoring and progress shall be submitted to the architect, and the general contractor.
6. Refer to soils report for further information.

7. After on-site soils engineer has determined when settlement has reached the acceptance limit, the site grading contractor is responsible for providing building pad elevations as shown on the grading plans.

C. AREAS OF CONSTRUCTION EXCLUSIVE OF THE BUILDING SUBGRADE:

1. Unless specifically stated otherwise on the drawing, areas exposed by excavation or stripping and on which subgrade preparations are to be performed shall be scarified to minimum depth of 8” and compacted to minimum of 98% of optimum density, in accordance with ASTM D 698, at a moisture content of not less than 1% below and not more than 3% above the optimum moisture content. These areas shall then be proof rolled to detect any areas of insufficient compaction. Proof rolling shall be accomplished by making a minimum of two (2) complete passes with a fully-loaded tandem-axle dump truck or approved equivalent, in each of the two perpendicular directions under the supervision and direction of a field geotechnical engineer. Areas of failure shall be excavated and replaced with suitable material per these specifications.
2. Unless specifically stated otherwise on the drawings, fill materials used in preparation of subgrade shall be placed in lifts or layers not to exceed 8” loose measure and compacted to a minimum density of 98% of optimum density, in accordance with ASTM D 698, at a moisture content of not less than 1% below and not more than 3% above the optimum moisture content.
3. The following table stipulates maximum allowable values for Plasticity Index (PI) and Liquid Limit (LL) of suitable fill materials to be used in the specified areas, unless specifically stated otherwise on the drawings.

<u>Location*</u>	<u>PI</u>	<u>LL</u>
Area below upper two feet, exclusive of building area	20	50
Upper two feet, exclusive of building area	15	40

*References to depth are to proposed subgrade elevations.

4. Material imported from off-site shall be CBR (California Bearing Ratio) value equal to or above the pavement design subgrade CBR value indicated on the drawings.

5. The site grading contractor shall provide and install all topsoil as indicated on the drawings and in conformance with landscaping plans and specifications.

3.05 MAINTENANCE OF SUBGRADE

- A. Finish subgrades shall be verified to ensure proper elevation and conditions for construction above subgrade.
- B. Protect subgrade from excessive wheel loading during construction, including concrete trucks and dump trucks.
- C. Remove areas of finished subgrade found to be insufficient for any reason to depth necessary and replace in a manner that will comply with compaction requirements per these specifications. Surface of subgrade after compaction shall be hard, uniform, smooth, stable and true to grade and cross-section.
- D. Grading of paving areas shall be within a tolerance of up to 0.10 feet as so long as it does not adversely affect drainage and other conditions. Contractor to provide engineering and field staking necessary for verification of lines, grades and elevations.
- E. Maintain subgrade for area to be paved. Make adjustments that may be required in accordance with specifications at no additional expense to Owner.

3.06 RIP-RAP

- A. Rip-rap shall be constructed as shown on the drawings.

3.07 FINISH GRADING

- A. Grade all areas where finish grade elevations or contours are indicated on drawings, other than paved areas, including excavated areas, filling transition areas and landscaped areas. Grading areas shall be uniform and smooth, free from rock, debris or irregular surface changes. Finished subgrade surface shall not be more than 0.10 feet above or below established finished subgrade elevation and all ground surfaces shall vary uniformly below indicated elevations. Finish ditches shall be graded to allow for proper drainage without ponding and in a manner than will minimize erosion potential. For topsoil application, refer to Section 02900 (LANDSCAPING, SEEDING AND SODDING).

- B. Correct all settlement and eroded areas within one year after date of substantial completion of all work at no additional expense to Owner. Bring grades to proper elevation.

3.08 FIELD QUALITY CONTROL

- A. Independent Testing Laboratory selected and paid by Owner, shall be retained to perform construction testing and act as the Owner's representative on site based on the following:
 - 1. Building Subgrade Areas, including 10'-0" Outside Exterior Building Lines: In cut areas, not less than one compaction test for every 2,500 square feet. In fill areas, same rate of testing for each lift (measured loose).
 - 2. Areas of construction exclusive of Building Subgrade: In cut areas, not less than one compaction test for every 10,000 square feet. In fill areas, same rate of testing for each lift (measured loose).
- B. In compaction requirements are not complied with at any time during construction process, remove and recompact deficient areas until proper compaction is obtained at no additional expense to Owner.
- C. In all areas to receive pavement, a CBR (or LBR) test shall be performed for each type of material imported from off-site.
- D. The following test shall be performed on each type of on-site or imported soil materials used as compacted fill as part of construction testing requirements.
 - 1. Moisture and Density Relationship: ASTM D 698 or ASTM D 1557.
 - 2. Mechanical Analysis: AASHTO T-88
 - 3. Plasticity Index: ASTM D 4318
- E. Field density tests for in-place materials shall be performed according to one of the following standards as part of construction testing requirements:
 - 1. Sand-Cone Method: ASTM D 1556
 - 2. Balloon Method: ASTM D 2167
 - 3. Nuclear Method: ASTM D 2922
(Method B-Direct Transmission)

- F. Independent Testing Laboratory shall prepare test reports that indicate test location, elevation data and test results. The architect and Contractor shall be provided with copies of reports within 96 hours of time test was performed. In event that any test performed fails to meet these specifications, Independent Testing Laboratory shall notify the General Contractor immediately.

The Contractor at no additional expense shall pay for all costs related to retesting due to failures to Owner. We reserve the right to employ an Independent Testing Laboratory and to direct any testing that is deemed necessary. Contractor shall provide free access to site for testing activities.

END OF SECTION

Section 02200-10

SECTION 02222 - EXCAVATION, BACKFILLING AND COMPACTING FOR UTILITIES

PART 1 – GENERAL

1.01 SUMMARY

This section includes the excavation, bedding and backfilling of utilities necessary to perform work indicated on drawings and contract documents.

1.02 RELATED REQUIREMENTS

Construction drawings
Specs. Section 02110 SITE PREPARATION
Specs. Section 02200 EARTHWORK

1.03 SUBMITTALS

- A. Shop drawings or details pertaining to site utilities are not required unless use of materials, methods, equipment or procedures contrary to drawings or these specifications are proposed. Do not perform work until required shop drawings have been accepted by Owner.
- B. The Contractor shall contact all utility companies and determine if additional easements will be required to complete the project. Contractor shall provide written confirmation of the status of ALL easements to the owner's Construction Manager at the time of the preconstruction conference or no later than 90 days prior to the project possession date.

PART 2 – PRODUCTS

- A. Bedding Material: Processed sand and gravel free from clay lumps, organic or other deleterious material and complying with following gradation requirements:

U.S. Sieve Size	Percent Passing (by weight)
1 inch	100
¾ inch	90-100
3/8 inch	20-55
No. 4	0-10
No.8	0-5

- B. Steel Casing Pipe: Comply with AWWA C-201 or C-202, minimum grade B, size and wall thickness as indicated on drawings.

PART 3 – EXECUTION

3.01 SUMMARY

- A. Set all lines, elevations and grades for utility and drainage system work and control system for duration of work, including careful maintenance of bench marks, property corners, monuments or other reference points.
- B. Maintain in operating condition existing utilities, active utilities and drainage systems encountered in utility installation. Repair any surface or subsurface improvement shown on drawings.
- C. Verify location, size, elevation and other pertinent data required to make connections to existing utilities and drainage systems as indicated on drawings. Contractor shall comply with local codes and regulations.

3.02 EXCAVATION, TRENCHING AND BACKFILLING

- A. Perform excavation as indicated for specified depths. During excavation, stockpile materials suitable for backfilling in orderly manner far enough from bank of trench to avoid overloading, slides or cave-ins.
- B. Remove excavated materials not required or not suitable for backfilling or embankments and waste off-site. Any structures discovered during excavation(s) shall be disposed of as specified.
- C. Prevent surface water from flowing into trenches or other excavations by temporary grading or other methods, as required. Remove accumulated water in trenches or other excavations by pumping or other acceptable methods.
- D. Open cut excavation with trenching machine or backhoe. Where machines other than ladder or wheel-type trenching machines are used, do not use clods for backfill. Dispose of unsuitable material and provide other suitable material at no additional cost to owner.
- E. All excavation shall be unclassified.

3.03 TRENCH EXCAVATION

- A. The local utility companies shall be contacted before excavation shall begin. Dig trench at proper width and depth for laying pipe, conduit or cable. Cut trench banks as nearly vertical as practical and remove stones as necessary to avoid point-bearing. Overexcavate rock, wet or unstable soil, if encountered, from trench bottom as necessary to provide suitable base for continuous and uniform bedding as directed by soils engineer.
- B. All trench excavation side walls greater than 5 feet in depth shall be sloped, shoring, sheeted, braced or other wise supported by means of the sufficient strength to protect the workmen within them in accordance with the applicable rules and regulations established for construction by the Department of Labor, Occupational Safety and Health Administration (OSHA), and by local ordinances. Lateral travel distance to an exit ladder or steps shall not be greater than 25 feet in trenches 4 feet or deeper.
- C. Accurately grade trench bottom to provide uniform bearing and support for each section of pipe on bedding material at every point along entire length, except where necessary to excavate for bell holes, proper sealing of pipe joint, or other required connections. Dig bell holes and depressions for joints after trench bottom has been graded. Dig no deeper, longer or wider than needed to make joint connection properly.
- D. Trench width requirements below the top of the pipe shall not be less than 12" not more than 18" wider than outside surface of any pipe or conduit that is to be installed to designated elevations and grades. All other trench width requirements for pipe, conduit or cable shall be at least practical width that will allow for proper compaction of trench backfill.
- E. Trench depth requirements measured from finished grade or paved surface shall meet the following requirements or applicable codes and ordinances.
 - 1. WATER MAINS: 36" to top of pipe barrel
 - 2. SANITARY SEWER: Elevations and grades as indicated on drawings.
 - 3. STORM SEWER: Depths, elevations and grades as shown on drawings.
 - 4. ELECTRICAL CONDUITS: 24" minimum to top of conduit or as required by NEC 300-5, NEC 710-36 codes or the local utility company requirements, whichever is deeper.
 - 5. TV CONDUITS: 18" minimum to top of conduit or as required by the local utility company, whichever is deeper.
 - 6. TELEPHONE CONDUITS: 18" minimum to top of conduit, or as required by the local utility company, whichever is deeper.
 - 7. GAS MAINS AND SERVICE: 30" minimum to top of pipe, or as required by the local utility company, whichever is deeper.

3.04 SHEETING AND BRACING

Provide sheeting and bracing, when necessary, in trenches and other excavations where protection of workmen required. Sheeting may be removed after sufficient backfilling to protect against damaging or injurious caving.

3.05 PIPE BEDDING

Accurately cut trenches for pipe or conduit that is installed to designed elevations and grades to line and grade from 4" below bottom of pipe and to width as specified. Place 4" of bedding material, compact in bottom of trench, and accurately shape to conform to lower portion of pipe barrel. After pipe installation, place select backfill as determined in Section 02200, and compact in maximum 8" layers measured loose to the top of the trench.

3.06 TRENCH BACKFILLING

- A. Criteria: Trenches shall not be backfilled until required test are performed and the utility systems comply with and are accepted by applicable governing authorities. Backfilling trenches as specified. If improperly backfilled, reopen to depth required to obtain proper compaction. Backfill and compact, as specified, to properly correct condition in an acceptable manner.
- B. Backfilling: After pipe or conduit has been installed, bedded and tested as specified, backfill trench or structure excavation with specified material placed in 8" maximum loose lifts. Compact to minimum density of 98% of optimum density in accordance with ASTM D 698.
- C. Compaction: Exercise proper caution when compacting immediately over top of pipes or conduits. Water jetting or flooding is not permitted as method of compaction.
- D. Compaction Testing: If determined by the owner and at the owner's expense an independent testing laboratory shall perform test at intervals not exceeding 200'-0" or trench for the first and every other eight-inch (8") lift of compacted trench backfill and furnish copies of test results as specified.

END OF SECTION

SECTION 02227 - BORING AND ENCASEMENT

PART 1 – GENERAL

1.1 GENERAL DESCRIPTION: This section covers the furnishing of all supervision, labor, equipment and materials required for the complete installation of encasement pipe and carrier pipes under highways and railroads by boring and jacking as shown on the drawings and specified herein.

1.2 GENERAL INTENTION: This section shall include construction methods for pipe lines installed by boring and jacking in the locations as shown on the contract drawings. The contractor shall inspect the locations at the proposed crossings and shall familiarize himself with the conditions under which the work will be performed, and with all necessary details and the suitability of his equipment and methods for the work required. All work in railroads shall comply with all current requirements of governing highways and railroad agencies. The Contractor shall be familiar with these requirements.

PART 2 – MATERIALS

2.1 The encasement pipe shall be of the size as shown on the contract drawings. All encasement pipe shall be smooth wall welded steel conforming to ASTM Designation A139, Grade B. The outside of the pipe shall be coated in accordance with AWWA Standard C203. Minimum pipe wall thickness shall be as follows:

Pipe-Nominal Diameter Inches	Wall Thickness Inches
16	.250
20	.250
24	.250
30	.312
36	.500

2.2 Steel spiders shall be galvanized.

PART 3 – EXECUTION

3.1 Encasements shall be installed by boring and jacking unless field conditions require otherwise. It shall be the Contractor's responsibility to notify the Engineer immediately if conditions do not permit a jack and bore installation.

- 3.2 Installation of encasement pipe shall include all related work and services such as mobilization of equipment, construction and maintaining working pits, right-of-way maintenance and restoration, traffic maintenance, mining, excavations, dewatering, sheeting, shoring and bracing for embankments, operating pits, and as elsewhere required shall be placed and maintained in order that work may proceed safely and expeditiously.
- 3.3 The encasement pipe shall be of the diameter indicated for the carrier pipe as shown on the drawings.
- 3.4 Boring Machine Alignment: The boring machine shall be accurately aligned before the boring is commenced and the Contractor shall take such necessary steps as are required to accurately place the encasement with respect to line and grade. Payment will not be made for a bore and encasement that is not accurate as to line and grade as determined by the Engineer.
- 3.5 Extension of Encasement Pipe: As the boring operation progresses, each new section of the encasement pipe shall be butt welded to the section previously jacked into place. The boring auger shall not be of a greater diameter than the outside diameter of encasement. The leading edge of the steel casing shall be kept as close to the auger head as possible and shall be advanced at the same rate of speed as the earth auger in order to minimize any unsupported holes in the earth. Any voids that occur are to be filled with 3:1 ratio sand to cement grout at 50 psi pressure, sand or pea gravel, as directed by the Engineer to insure that there will be no settlement. The Engineer will direct that this space be filled if the space is large enough to cause any earth settling. There will be no payment for grout work.
- 3.6 Before the pipe is installed in the casing, bolt-on meter skids painted with bitumastic paint shall be rigidly fastened to the barrel of the pipe. After completion of the casing, the Contractor shall insert the pipeline in the pre-jointed segments. No contact will be permitted between the casing and the carrier pipeline.
- 3.7 Obstructions: In the event that an obstruction is encountered during the boring operation which cannot be penetrated as determined by the Engineer, the auger is to be withdrawn and the steel pipe encasement is to be cut off, capped and completely filled with 3:1 ratio sand to cement grout at 50 psi pressure before moving to a new site. Payment will be made by the Owner on completed before the boring operation was stopped plus the additional linear footage at the new site. There will be no payment for the grout work.

- 3.8 Pipeline Installation: After completion of the boring and encasement, the Contractor shall insert the pipeline in pre-jointed segments. A galvanized steel spider shall be installed behind each carrier pipe bell in the encasement pipe, as shown on the Contract Drawings. After placing and jointed the pipeline, the ends of casing pipes and tunnels shall be closed with brick masonry bulkheads.
- 3.9 Method of Measurement: Measurement will be in feet along the flow line of the encasement pipe which is installed.
- 3.10 Basis of Payment: The quantity of encasement pipe measured as provided in paragraph entitled "Method of Measurement" will be paid for at the contract unit price per linear feet.
- 3.11 Payment shall be for the total number of lineal feet of encasement pipe installed at the respective unit price bid for the item.
- 3.12 Price and payment shall constitute full compensation for furnishing all equipment, labor, tools, and materials to complete all of the work required under this section including excavation of working pits, encasement pipe, carrier pipe, dewatering, shoring, etc.

End Section

SECTION 2570 – BITUMINOUS PAVEMENT REPAIR

1.1 INTRODUCTION

The scope of this section is to furnish all labor, equipment, materials and any other items necessary to replace or repair all asphalt surfaces. All work shall be performed in conformance with the applicable sections of the North Carolina Department of Transportation, Division of Highways, “Standard Specification for Roads and Structures”(Latest Edition).

1.2 PERFORMANCE

Asphalt mixtures shall not be prepared or placed when the average ambient temperature is less than 40 degrees farenheight, during rainy weather, when sub grade or base course is frozen, when sub grade or base course is showing evidence of excess moisture or when the surface to be adjoined to is excessively moist and would prevent proper bonding with the new surface.

Preparation and construction of sub grade, base course and surface course shall be completed immediately after completion of all underground piping or structures, installation of curb and gutters, all yard piping, conduits and other facilities passing under paved areas and all structural slabs and foundations required within or adjacent to the paved areas.

1.3 INSTALLATION

A. Sub grade Preparation:

Sub grade preparation activities shall be in strict conformance with Section 500 or Section 505, where applicable, of the “Standard Specifications for Road and Structures” (Latest Edition) issued by NCDOT- Div. of Highways.

B. Aggregate base Course Installation:

Application of aggregate base course shall be in strict conformance with Section 520 of the “Standard Specification for Roads and Structures” (Latest Edition) issued by NCDOT- Div. of Highways.

C. Bituminous Plant Mix – General:

The work covered under this section of this specification shall be performed in strict conformance with Section 610 and Section 620 of the “Standard Specifications for Road and Structures” (Latest Edition) issued by NCDOT- Div. of Highways.

D. Prime Coat:

The work covered under this section of this specification shall be performed in strict conformance with Section 600 of the “Standard Specifications for Road and Structures” (Latest Edition) issued by NCDOT- Div. of Highways.

E. Tack Coat:

The work covered under this section of this specification shall be performed in strict conformance with Section 605 of the “Standard Specifications for Road and Structures” (Latest Edition) issued by NCDOT- Div. of Highways.

F. Bituminous Surface Course (S 9.5B):

The work covered under this section of this specification shall be performed in strict conformance with NCDOT Superpave specifications (Latest Edition) issued by NCDOT- Div. of Highways.

G. Traffic Markings:

The Contractor shall repair and restore any traffic markings that were damaged, destroyed or covered during the construction operation. All work shall be done in accordance with the requirements and specifications of NCDOT and in conformance with the MUTCD Manual (Latest Edition). The payment for work under this section shall be included in the unit bid price for bituminous surface coat and no additional payment will be made.

H. Existing Structures:

All existing structures which fall under or near repaired or restored bituminous areas shall be adjusted to final grade prior to application. All work under this section shall be included in the unit bid price for bituminous surface coat and no additional payment will be made if depicted on the plans. All encountered structures, which were not depicted on the plans or visible, will be paid at agreed upon price by Contractor and Engineer/Owner.

I. Testing and Acceptance:

All work in this section shall be subject to thickness and compaction tests as deemed necessary by the Engineer/Owner. All tests shall be included in the unit bid price for bituminous paving and paid by the Contractor. All tests found to be in nonconformance require the removal, replacement and restoration of areas in question. For additional tests requested by the Engineer/Owner, the Owner will pay for all successful tests and the Contractor shall pay for tests resulting in nonconformance and repair area as previously discussed. Compaction test shall be required as follows:

1. One test per intersection.
2. One test per road crossing less than 100 feet.
3. One test per 500 feet for excavations in a bituminous area.

Upon submittal of successful test reports and aesthetic acceptance, the Contractor shall be given an acceptance of the work in writing. The Contractor shall remain responsible for all improvements until final acceptance of the project.

END OF SECTION

SECTION 02601 - MANHOLES, DROP MANHOLES AND CONFLICT MANHOLES

1. DESCRIPTION: The Contractor shall furnish all labor, materials, equipment and supplies and shall perform all work necessary for the construction of all manhole drop connections and conflict manholes complete and ready for use. The manhole drop connections and conflict manholes shall be constructed at the locations and grades shown or established by the Engineer and shall conform to the details shown on the Plans.

1.1 Any reference to NCDOT standard specifications was obtained from "Standard Specification for Roads and Surfaces" published by the North Carolina Department of Transportation. Unless otherwise noted, the most current date published applies.

2. MATERIALS:

Materials for manholes shall be new and shall be furnished by the Contractor in accordance with the following requirements:

2.1 Manholes: Manholes shall be precast reinforced concrete sections conforming to ASTM C-478 and to the following.

2.1.1 Tops shall be eccentric cone where cover permits unless shown otherwise on the drawings and flat slab tops otherwise. Bottoms shall be integrally cast unless the Contractor proposes to use specialty bases ("Dog-House") at points of connection to existing sewer mains. Any special bases or riser used must be detailed in shop drawings and submitted for approval. Manhole wall and base dimensions shall conform to C-478 or to the minimum dimensions shown on the drawings.

2.1.2 Manhole supplier shall design manhole sections to resist earth loads and to resist uplift resulting from buoyant forces calculated with ground water table at the ground surface. Wall and base dimensions shall be increased accordingly.

2.1.3 Pipe connection shall consist of an approved continuous boot of 3/8 inch minimum thickness neoprene as shown on the drawings conforming to ASTM C-923. Boots shall be either cast into the manhole wall or installed into a cored opening using internal compression rings. Installed boot shall result in a water-tight connection meeting the performance requirements of ASTM C-443.

2.2 Frames and Covers: Frames and covers shall be of domestic manufacture good quality cast iron of uniform grain, conforming to ASTM A48, Class 30 or better, constructed in accordance with details shown on the plans.

- 2.3 Manhole Steps: Manhole steps shall be of aluminum or composite plastic-steel construction. Aluminum steps shall be aluminum alloy 6061T6. Composite plastic-steel steps shall consist of a ½ inch deformed steel reinforcing rod encapsulated in a co-polymer polypropylene plastic; reinforcing rods shall conform to ASTM A615, Grade 60; and polypropylene plastic shall conform to ASTM D2146, Type II, Grade 16906. Minimum design live load of steps shall be a single concentrated load of 300 pounds. Steps shall be nine inches in depth and at least twelve inches in width. Steps shall have non-skid top surfaces. All parts of aluminum steps to be embedded in concrete or masonry shall be coated with bituminous paint or zinc chromate primer.
- 2.3.1 Steps shall be uniformly spaced not more than sixteen inches (16”) on center, including the spacing between the top step and the manhole cover. Steps shall be embedded in the wall a minimum distance of 4 inches in either cast or drilled holes. Steps shall not be driven or vibrated into fresh concrete and shall withstand a pullout resistance of 2000 lbs when tested in accordance with ASTM C-497. Each step shall project a minimum of 5 inches from the wall measured from the point of embedment.
- 2.4 Concrete (poured in place): Air entrained Portland Cement Concrete having minimum twenty-eight (28) day compressive strength of 3000 psi.
- 2.5 Joint Sealant: Butyl Rubber based conforming to AASHTO M-198, type B – Butyl rubber, suitable for application temperatures between 10 and 100 degrees F.
- 2.6 O-Ring or Gasket (Contractor’s option): ASTM C-443
- 2.7 Sand Cement:
- 2.7.1 Portland Cement: ASTM C50, Type I.
- 2.7.2 Sand: Clear, sharp, graded from fine to coarse, ASTM C-144.
- 2.7.3 Water: Clean and potable.
- 2.7.4 Mixture: One (1) part cement, two (2) parts sand.
- 2.8 Pipe and Fittings: Same as sewer pipe.
- 2.9 Precast Grade Rings: Shall be no less than 4” in height and conform to ASTM C 478.

- 2.10 Washed Stone: Stone material, crushed stone or gravel shall be strong, durable and conform to standard size No. 57 per NCDOT Section 1000.
3. CONSTRUCTION:
- 3.1 Excavation for all sanitary manholes shall be carried to a depth such as to provide a minimum of 6 inches of washed stone bedding material below the bottom of structures and extend to a minimum width of 8 inches beyond each side of structures.
- 3.2 Should unstable soil, organic soil, or soil types classified as fine-grained soils (silts and clays) by ASTM D-2487 be encountered at the bottom of excavations, such soils shall be removed to a depth and width determined by the Engineer and properly disposed of. The resulting undercut shall be backfilled with washed stone. Placement and compaction shall conform to applicable earthwork specifications.
- 3.3 Manholes shall be constructed of precast reinforced concrete with cast iron frames and covers in accordance with details shown on the Plans.
- 3.4 Invert channels shall be smooth and accurately shaped to semi-circular bottom conforming to the inside of the adjacent sewer sections. Inverts shall be formed of concrete, and no laying pipe through manholes will be permitted. Changes in size and grade shall be made gradually and evenly. The minimum bending radius of the trough centerline shall be 1.5 times the pipe I.D. A minimum ½” radius shall be provided at the intersection of 2 or more channels.
- 3.5 Precast concrete bottom sections, risers, and top sections shall be fabricated such that when assembled, they provide a manhole conforming to the depth required. The Contractor shall be responsible for the furnishing and constructing manholes such that the completed assembly is flush (0.1 foot above) finished grade or at other elevations as may be shown on the drawings. No manhole assembly will be accepted or paid for that will allow surface water inflow to occur through the cover due to poor attention to construction grades.
- 3.6 Sections are to be assembled so as to provide a plum structure with uniform bearing at all joints and at the base slab. Joints shall be thoroughly cleaned to remove dirt and foreign material. The butyl rope sealant shall be unrolled directly against the base of the spigot. Leave the protective paper in place until the sealant is fully in place. Overlap rope from side to side, not top to bottom. Joints to be plastered smooth inside and outside of manhole with a cement grout. JOINTS SHALL BE WATER TIGHT.

- 3.7 Pipes shall project into the manhole 2 inches and shall be mechanically sealed with a MOLDED NEOPRENE boot.
- 3.8 Manhole frames and covers shall be set flush (0.1 foot above) with the finished grade or as otherwise shown on the drawings. Precast adjustment (grade) rings shall be used as required. No more than 8 vertical inches of grade ring will be allowed per manhole. Seal frame to adjustment ring, or cone section with butyl sealing rope and completely grout the ring to the top manhole section.
- 3.9 Drop connections shall be constructed with ductile iron outside the manhole unless approved otherwise by the Director.
4. TESTING: All manholes shall be tested in accordance with the Infiltration/Ex-filtration Test in Section 02730, unless otherwise directed by the Director.
5. METHOD OF MEASUREMENT AND BASIS OF PAYMENT: Manholes, Drop Connections, Manhole Vent Pipes, existing manhole removal and existing manhole abandonment shall be paid for at the unit prices specified in the Bid. All prices shall be for full payment for all labor, materials, tools, equipment, backfilling, sheeting, shoring, dewatering, and other costs necessary to complete the work as shown, directed and specified.
 - 5.1 Manholes are to be measured and the depth determined as the vertical distance between top of the cast iron frame and the lowest pipe invert and rounded to the nearest foot.
 - 5.2 Drop Connections will be measured and paid for at the price per vertical foot, rounded to the nearest foot.
 - 5.3 Payment for manholes constructed over existing sewers shall be lump sum for each specialty manhole identified, including all appurtenances for a complete installation at each location identified.

END OF SECTION

Section 02601-4

SECTION 02722 - EXTERIOR SANITARY SEWERS AND APPURTENANCES

PART 1 – GENERAL

- 1.1 General Description: This section covers the furnishing of supervision, materials, labor, equipment and miscellaneous items necessary to construct sewers and appurtenances as shown on the plans and as specified herein, complete, tested, and ready for service. All pipe and appurtenances shall be of the class and type as indicated on the plans and designated herein.
- 1.2 General Intention: The work covered by this section consists of all supervision, excavation, bedding, laying pipe, jointing and coupling pipe sections, and backfilling necessary to install the various types of pipe required to complete the project.

PART 2 – MATERIALS

- 2.1 Materials: All materials shall be first quality with smooth interior and exterior surfaces, free from cracks, blisters, honeycombs and other imperfections, and true to theoretical shapes and forms throughout. All materials shall be subject to the inspection of the Engineer at the plant, trench, or other point of delivery, for the purpose of culling and rejecting material that does not conform to the requirements of these specifications. Such material shall be marked by the Engineer and the Contractor shall remove it from the project site upon notice being received of its rejection. As particular specifications are cited, the designation shall be construed to refer to the latest revision under the same specification number, or to superseding specifications under a new number except provisions in revised specifications that are clearly inapplicable.
 - 2.1.1 Handling and Storing Materials: The Contractor shall unload pipe so as to avoid deformation or other injury thereto. Pipe shall not be rolled or dragged over gravel or rock during handling. When any joint or section of pipe is damaged during transporting, unloading, handling, or storing, the undamaged portions of the joint or section may be used where partial lengths are needed, or, if damaged sufficiently, the Engineer will reject the joint or section as being unfit for installation. If any defective pipe is discovered after installation, it shall be removed and replaced with sound pipe or shall be repaired by the Contractor in an approved manner and at their own expense.
- 2.2 PIPE AND FITTINGS:
 - 2.2.1 Polyvinyl Chloride Pipe (PVC): Polyvinyl Chloride Pipe (PVC) pipe shall meet the requirements of ASTM D3034, latest editions, and be suitable for use as a gravity sewer conduit. The pipe shall be SDR 35 unless otherwise specified. The pipe shall be supplied in standard laying lengths of 20 feet and 12.5 feet.

- 2.2.1.1 PVC Pipe Joints: All PVC pipe joints shall be of an integral bell and spigot of the same material as the pipe with a solid cross-section rubber O-ring securely locked in place at the point of manufacture. Service saddles and other fittings shall be supplied by the pipe manufacturer and shall be of the same material and type of construction as the pipe material.
- 2.2.3 Ductile Iron Pipe (DIP): Ductile Iron Pipe shall be manufactured in accordance with ANSI Specification A21.51. All ductile iron pipe shall be Class 50 unless other wise specified and shall be lined with cement mortar not less than 1/16"-inch thick conforming to ANSI Specification A21.4.
- 2.2.3.1 DIP Joints: Slip or "push-on" joints shall be manufactured in accordance with ANSI Specification A21.11. Bells of "slip" joint pipe shall be contoured to receive a bulbshaped, circular rubber gasket, and plain ends shall have a slight taper to facilitate installation. The pipe manufacturer shall furnish the lubricant used in making up the joints. The jointing shall be done by guiding the plain end into the bell until contact is made with the gasket and by exerting a sufficient compressive force to drive the joint home until plain end makes full contact with the base of the bell.
- 2.2.4 Reinforced Concrete Pipe: Reinforced concrete pipe shall be furnished in sizes and classes shown and specified on the Contract Drawings and the Bid Schedule. All pipes under this Section shall conform to the latest revisions of ASTM CC-76 – Reinforced Concrete Culvert, Storm and Sewer Pipe. The provisions of ASTM C-655 may also be utilized. Reinforced concrete pipe shall be manufactured by centrifugal or vertical casting methods. For vertical casting methods, mechanical vibration shall be provided to insure proper consolidation of concrete. Density of cured concrete shall be 150 lbs/ft. or greater.
- 2.2.4.1 Concrete Pipe Test: All shipments of pipe shall be tested at the Contractor's expense in accordance with ASTM C-76 Section 11 (2) except as modified. Preliminary testing for extended deliveries shall include 3-edge bearing tests to the .01-inch crack on three (3) sections of each size pipe. Testing shall be by an approved testing laboratory. Specimens up to 0.5 percent of the number of each size of pipe furnished shall be tested, except that in no case shall less than two specimens be tested. The laboratory making the tests shall furnish the Engineer with three (3) certified copies of these tests. No pipe shall be laid before the Engineer approves test reports.
- 2.2.4.2 Concrete pipe shall be manufactured in joint lengths of 8 feet or greater.
- 2.2.4.3 Results of absorption tests performed on the pipe shall not exceed 6.5 percent.

- 2.2.4.4 The alkalinity of the concrete cover over the inner reinforcing steel on the inside pipe wall at the crown shall be no less than 0.50 (50%) expressed as calcium carbonate equivalent. The manufacturer shall determine the alkalinity of the concrete cover at intervals determined by the Engineer. Samples for alkalinity determination shall be obtained by drilling one-inch diameter holes in the pipe interior to the reinforcing steel. The ground concrete from this drilling shall be the sample material used for the alkalinity determination. Core holed in test pipe may be suitably repaired by a method approved by the Engineer and used on the project. The laboratory making the test shall furnish the Engineer with three (3) certified copies of these tests. No pipe shall be laid before the Engineer approves these reports.
- 2.2.4.5 Bell and spigot reinforced concrete sewer pipe shall be joined with an O-ring rubber gasket type joint conforming to the applicable provisions of ASTM C-361, latest revisions. A groove shall be provided in the spigot end to receive the rubber gasket and it shall be so formed that when the joint is complete, the gasket will be deformed to a near rectangular shape and confined on all four sides. All inside surfaces of the bell and outside closure of the joint, and at any degree or partial closure shall be parallel within one degree and have an angle of not more than two degrees with the longitudinal axis of the pipe. The gasket shall be the sole element utilized in sealing the joint from either internal or external hydrostatic pressure. Gaskets shall be the product of a manufacturer having at least five years' experience in the manufacturer of rubber gaskets for pipe joints. The gaskets shall have smooth surfaces free from blisters, porosity, and other imperfections. The joint shall be assembled in accordance with the standard directions of the gasket manufacturer.
- 2.2.4.6 The pipe manufacturer shall design walls to meet the following requirements.
- 2.2.4.6.1 Pipe wall sections shall meet the structural requirements for pipe classes stated in the Bid Schedule for each size pipe.
- 2.2.4.6.2 Concrete cover over the inner reinforcing cage shall be a minimum of 1" greater than that required to meet structural properties. This may be accomplished by moving the inner reinforcing cage towards the outside of the pipe, by adding concrete on the inside of the pipe, by adding concrete on the outside of the pipe, or both. Inside pipe diameter shall not be decreased.
- 2.2.4.6.3 Reinforcing shall be sufficiently strong so that the pipe, without the additional interior cover, will meet the 3-edge bearing test requirements of ASTM C-76 for the .01-inch crack.

- 2.2.5 Steel Sanitary Sewer Pipe: Steel sanitary sewer pipe shall conform to ASTM A-53 Grade B or ASTM A-139 Grade B standard specifications. Steel sewer pipe shall have minimum yield strength of 35,000 psi and a minimum tensile strength of 60,000 psi with a wall thickness of .375 inches. External and internal surfaces shall have protective coatings. Coating shall consist of a coal-tar primer followed by hot coal-tar enamel at least 1/16-inch thick, or approved equal.
- 2.2.6 Steel Casing Pipe: Steel casing shall conform to ASTM A-53 Grade B or ASTM A-139 Grade B Standard specifications. Casing pipe shall have a wall thickness as follows:

30"	0.312 inches wall thickness
26"	0.312 inches wall thickness
16"	0.250 inches wall thickness

External surfaces of steel casing pipe to have a protective coating. This coating shall consist of a coal-tar primer followed by hot coal-tar enamel at least 1/16-inch thick, or approved equal.

- 2.3 Manholes: See Section 02601 Manholes, Drop Manholes and Conflict Manholes

PART 3 – EXECUTION

- 3.1 Preparation of Pipe Foundation: The pipe foundation shall be prepared to be uniformly firm and shape be true to the lines and grades as shown on the Contract Drawings. Any deviation or field adjustment will require the approval of the Engineer. The Contractor shall be responsible for the finished work conforming to proper line and grade.
 - 3.1.1 Bedding: Whenever the nature of the ground will permit, the excavations at the bottom of the trench shall have the shape and dimensions of the outside lower third of the circumference of the pipe, care being taken to secure a firm bearing support uniformly throughout the length of the pipe. A space shall be excavated under and around each bell to sufficient depth to relieve it of any load and to allow ample space for filling and finishing the joint. The pipe, when thus bedded firmly, shall be on the exact grade. In case the bed shape in the bottom of the trench is too low, the pipe shall be completely removed from position, and earth of suitable quality shall be placed and thoroughly tamped to prepare a new foundation for the pipe. In no case shall the pipe be brought to grade by blocking up under the barrel or bell of the same, but a new and uniform support must be provided for the full length of the pipe. Where rock or boulders are encountered in the bottom of the trench, the same shall be removed to such depth that no part of the pipe, when laid to grade, will be closer to the rock or boulders than 6 inches. A suitable tamped and shaped foundation of approved material shall be placed to bring the bottom of the trench to proper subgrade over rock or boulders.

The preparation of the pipe bedding shall be in accordance with the typical trench cross sections as shown on the Contract Drawings for the type of pipe being installed. Crushed stone use for pipe bedding shall be shovel sliced so that the materiel fills and supports the haunch area and encases the pipe to the limits shown on the trench cross sections.

3.1.2 Bedding at Creek Crossing: Where it is necessary to cross a creek, the following requirements pertain.

- 1a) One foot of cover where the sewer is located in rock.
- 2a) Three feet of cover in other material unless ferrous pipe is specified. More cover in major streams.
- 3a) In paved stream channels, the top of the sewer line shall be placed below the bottom of the channel pavement.

3.1.3 Proper backfilling shall take place to prevent erosion or siltation.

- 1a) If crossing above water, Ductile Iron Pipe shall be used and the bottom of the pipe shall be above the 25-year flood elevation and special care taken to ensure minimal erosion on the creek banks.

3.1.4 Poor Foundation Material: Where the foundation material is found to be of poor supporting value, the Engineer may make minor adjustment in the location of the pipe to provide a more suitable foundation. Where this is not practical, the foundation shall be conditioned by removing the existing foundation material by undercutting to the depth as directed by the Engineer and backfilling with foundation conditioning material consisting of crushed stone.

3.1.5 Crushed Stone for Pipe Bedding: Crushed stone for pipe bedding and for foundation conditioning is to be size #67 in ASTM designation D 488, "Standard Sizes of Coarse Aggregate for Highway Construction: (AASHTO M-43, size #67)

The sieve analysis of #67 stone is as follows:

passing 1"	100%
passing 3/4"	90% - 100%
passing 3/8"	20% - 55%
passing #4	0% - 10%
passing #8	0% - 5%

3.2 Water in Pipe Trench: The Contractor shall remove all water which may encountered or which may accumulate in the trenches by pumping or bailing and no pipes shall be laid until the water has been removed from the trench. Water so removed from the trench must be disposed of in such a manner as not to cause damage to work completed or in progress.

3.3 LAYING PIPE:

- 3.3.1 Manufacturer's Recommendations: All piping is to be installed in strict accordance with the manufacturer's recommendations and the contract material specifications.
- 3.3.2 Proper Tools and Equipment: Proper tools, implements, and facilities satisfactory to the Engineer shall be provided and used for the safe and convenient protection of pipe laying. All pipe and other materials used in the laying of pipe will be lowered into the trench piece by piece by means of a suitable equipment in such a manner to prevent damage to the pipe, materials, to the protective coating on the pipe, materials, and to provide a safe working condition to all personnel in the trench. Each piece of pipe being lowered into the trench shall be clean, sound and free from defects. It shall be laid on the prepared foundation, as specified elsewhere to produce a straight line on a uniform grade, each pipe being laid so as to form a smooth and straight inside flow line. Pipe shall be removed at any time if broken, damaged or displaced in the process of laying same, or of backfilling the trench.
- 3.3.3 Cutting Pipe: When cutting short lengths of pipe, a pipe cutter as approved by the Engineer will be used and care will be taken to make the cut at right angles to the center line of the pipe or on the exact skew as shown on the plans. In the case of push-on pipe, the cut ends shall be tapered with a portable grinder or coarse file to match the manufactured taper.
- 3.3.4 Location of Groove or Bell: All pipe shall be laid with the groove or bell end up grade, and the spigot or tongue fully inserted. All pipe joints will be constructed in strict accordance with the pipe manufactures specifications and materials and any deviation must have prior approval of the Engineer.
- 3.3.5 Pipe Deflection: All pipe installations shall be tested for deflection. No pipe shall exceed deflection of 5 percent. The maximum deflection per joint of flexible joint pipe shall be that deflection recommended by the manufacturer. A stopper or plug shall be installed in the pipe mouth when pipe laying is not in progress.

3.4 MINIMUM SEPARATION:

3.4.1 The following minimum separations must be maintained:

- a) Any private or public water supply source consisting of wells, WS-I waters, Class I, Class II, or Class III reservoirs used a source of drinking water 100ft.
- b) Waters classified WS-II, WS-III, WS-IV, B, SA, ORW, HQW, or SB from normal high water or tide elevation, wetlands that are directly abutting these waters, and wetlands classified as UWL or SWL 50ft.

- c) Any other stream, lake, impoundment, wetlands classified as WL, waters classified as C, SC, or WS-V, or ground water lowering and surface drainage ditches 10ft.
- d) Any building foundation 5ft.
- e) Any basement 10ft.
- f) Top slope of embankment or cuts of 2 feet or more of vertical height 10ft.
- g) Interceptor drains & drain lines 5ft.
- h) Any swimming pool 10ft.
- i) Storm sewers (vert.) 18in.
(horiz.)12ft.
- j) Water mains (vert.) 18in.
(horiz.)10ft.
- k) Benched trenches (horiz.)18in.

3.4.2 Where the required minimum separations cannot be maintained, ferrous sanitary sewer pipe with joints equivalent to water main standards must be used. However, the minimum separations shall not be less than 25 feet from a private well or 50 feet from a public water supply source.

3.5 SIZE:

3.5.1 The minimum size of public gravity sewer mains shall be 8”.

3.5.2 New sewer systems shall be designed based on the proposed land use of the contributory area. The following flow factors shall be used:

PROPOSED LAND USE	FLOW FACTOR
Residential	120 gal/bedroom/unit
Office and Institutional	.09 gad/ sq. ft.
Commercial	.12 gad/ sq. ft.
Industrial	.20 gad/ sq. ft.

3.5.3 Flow factors not described shall be in conformance recommendations of NCDEQ.

- 3.5.4 Sanitary sewers shall be designed to carry the projected peak flow at no more than 2/3 full and at a minimum velocity of 3 fps. The ratio of peak flow to average daily flow shall be 3.
- 3.5.5 Sewer extensions are to be designed to meet proposed flow requirements even if larger than existing. If proposed is larger than existing then a manhole is to be set and the larger line is to be placed so that the energy gradient of the two lines are similar.

3.6 INSTALLATION:

3.6.1 Minimum slopes for pipe shall adhere to the following table.

Diameter of Pipe (inches)	Minimum slope (feet per 100 feet)
6	0.60
8	0.40
10	0.28
12	0.22
14	0.17
15	0.15
16	0.14
18	0.12
21	0.10
24	0.08
27	0.07
30	0.06
36	0.05

- 3.6.2 Sanitary sewer lines shall be deep enough to serve all adjoining property and allow for sufficient slope in lateral lines. All sanitary sewer mains shall have the following minimum covers:
 - a) 4 ft. from top of pipe to finish subgrade when under a roadway.
 - b) 3 ft. from top of pipe to finished subgrade when outside a roadway.
- 3.6.3 The above requirements may be waved by authority of Director, in which case ductile iron pipe shall be used.
- 3.6.4 Sewer mains deeper than 12 feet require stone bedding.
- 3.6.5 Transitions between pipe materials shall occur at manholes.

- 3.6.6 Where sanitary sewer lines and water lines must cross, ductile iron pipe shall be used and pipes shall cross at near 90 degree angles with 18" minimum separation, as stated in the separation table.
 - 3.6.7 Sewer mains shall be installed in dedicated public right of ways or in dedicated utility easements.
 - 3.6.8 Sewer line easements shall be graded smooth, free from rocks, boulders, roots, stumps, and all other obstructions and seeded and mulched upon completion of construction.
 - 3.6.9 Downstream manholes on sanitary sewer lines under construction shall be plugged and secured to prevent any seepage of water into or out of the line while under construction.
- 3.7 BACKFILL:
- 3.7.1 Initial Backfill: The initial backfill for pipe shall be carefully placed to a level of 12 inches over the top of the pipe. This backfill shall be excavated soil free from debris, organic material and large rock and stones. Initial backfill shall be shovel sliced so that the material fills and supports the haunch area and encases the pipe to the limits shown on the trench cross sections on the Contract Drawings.
 - 3.7.2 Final Backfill: Final backfill for pipelines shall be defined as that portion of the trench from an imaginary line drawn 12 inches above the top of the pipe to the original ground surface. Final backfill will be done with suitable excavated material and tamped in 12 inch lifts. Debris, material not given to adequate compaction, and stone over one cubic foot will not be allowed within the trench limits. If material excavated is not suitable for backfilling, the Contractor shall, at no increased cost to the Owner, remove and dispose of such unsatisfactory material and shall backfill the trench with suitable material obtained elsewhere.
 - 3.7.3 Steep Slope Protection: Sewers on 20 percent slopes or greater shall be anchored securely with concrete, or equal, with the anchors spaced as follows:
 - a) Not greater than 36 feet center to center on grades 21% to 35%
 - b) Not greater than 24 feet center to center on grades 35% to 50%
 - c) Not greater than 16 feet center to center on grades 50% and over

3.8 COMPACTION:

- 3.8.1 Within Traffic Areas: When pipelines installed within the ditch to ditch limits of any roadway, driveway or parking area etc., backfill shall be compacted to a minimum dry density of 95 percent of the maximum dry density in pounds per cubic foot as determined by the Standard Proctor Compaction Test. Backfill material shall be placed in 6 inch layers and thoroughly tamped or rolled to the required degree of compaction by sheepsfoot or pneumatic rollers, mechanical tampers, vibrators, etc. Successive layers shall not be placed until the layer under construction has been thoroughly compacted.
- 3.8.2 Outside Traffic Areas: In areas outside the ditch to ditch limits of a roadway, driveway, parking areas, etc., backfill shall be compacted to a minimum dry density of 90% of the maximum dry density in pounds per cubic foot as determined by the Standard Proctor Compaction Test. Any settlement shall be immediately corrected.
- 3.8.3 Equipment Traffic: Heavy equipment shall not be operated over any pipe until it has been properly backfilled and has a minimum cover of 24 inches. Where any part of the required cover is above the proposed finish grade, the Contractor shall place, maintain, and finally remove such material at no cost to the Owner. Pipe which becomes misaligned, shows excessive settlement, or has been otherwise damaged by the Contractor's operations shall be removed and replaced by the Contractor at no cost to the Owner.
- 3.8.4 Pipe Maintenance: The Contractor shall maintain all pipes installed in a condition that they will function continuously from the time the pipe is installed until the project is accepted.

3.9 MANHOLE INSTALLATION:

- 3.9.1 Precast Concrete Manhole: A precast concrete manhole shall be installed at each break in line or grade in each sanitary sewer as shown in detail on the Contract Drawings. Manhole sections shall be set plumb and on a firm foundations. Each joint between sections and all wall openings shall be sealed with 2:1 sand-cement mortar mix and made watertight. An eccentric cone section and standard frame and cover is to be installed on each new manhole. Final adjustment to grade of all manholes shall be done with brick and mortar and each frame and cover shall be grouted firmly into place.
- 3.9.2 Manholes shall be spaced at a maximum distance of 425 feet apart for lines 12 inches in diameter or smaller and at a maximum of 500 feet apart for lines greater than 12 inches in diameter.

3.9.3 Manholes for sewers under 21 inches in diameter shall be a minimum of 4 feet in diameter. Manholes for sewer 21 inches in diameter or greater shall be 5 feet in diameter. All manholes requiring inside drops shall be a minimum of 5 feet in diameter. When two or more inside drops occur at one manhole, a minimum of 6 feet in diameter manhole shall be used. All manholes shall have a minimum access of 22 inches in diameter.

3.9.4 Manholes Inverts: Manhole inverts shall be constructed of concrete or concrete and brick of semicircular section conforming to the inside diameter of the outlet sewer. Changes in size of pipe or grade shall be made gradually and changes in direction constructed by using true curves. Each manhole shall be provided with such channels for all connecting sewer pipes. Drop manholes shall be provided where invert separations exceed 2.5 feet.

3.9.5 Manholes located within the 100 year flood plain or in areas of high ground water shall abide by the following when applicable:

3.9.5.1 WATERTIGHTNESS:

3.9.5.1.1 Manholes shall be pre-cast concrete or poured-in-place concrete. Manhole lift holes and grade adjustment rings shall be sealed with non-shrinking mortar or other material approved by the Division.

3.9.5.1.2 Inlet and outlet pipes shall be joined to the manhole with a gasketed flexible watertight connection or any watertight connection arrangement that allows differential settlement of the pipe and manhole wall to take place.

3.9.5.1.3 Watertight manhole covers are to be used wherever the manhole tops may be flooded by street runoff or high water. Locked manhole covers may be desirable in isolated easement locations or where vandalism may be a problem.

3.9.5.2 Manholes shall be designed for protection from the 100-year flood by either:

3.9.5.2.1 Manhole rims shall be 12 inches (1 foot) above the 100-year flood elevation or,

3.9.5.2.2 Manholes shall be watertight and vented 12 inches (1 foot) above the 100-year flood elevation. Manholes shall be vented every 1,000 feet or every other manhole, whichever is greater.

3.9.6 CORROSION PROTECTION FOR MANHOLES:

3.9.6.1 Where corrosive conditions due to septicity or other causes are anticipated, consideration shall be given to providing corrosion protection on the interior of the manholes.

3.9.6.2 Where high flow velocities are anticipated, the manholes shall be protected against displacement by erosion and impact. High velocity is defined as 15 fps or greater.

3.10 Testing: All pipe installations shall be tested as specified herein. Tests shall be performed by Contractor at his expense in the presence of the Engineer or his representative. Testing shall not be performed until such time that all work which may affect the results of the testing has been completed. Where a test section fails to meet test requirements, Contractor shall make corrections as specified herein and retest the section. The correct/retest procedure shall continue until such time as test requirements are met.

3.10.1 Air Test: All gravity sewer pipe.

3.10.1.1 Air test shall be conducted in strict accordance with the testing equipment manufacturer's instructions, including all recommended safety precautions. No one will be allowed in the manholes during testing. Equipment used for air testing shall be equipment specifically designed for this type of test, and is subject to approval of the Inspector

3.10.1.2 The test shall be performed only on clean sewer mains after services are installed and the pipe is completely backfilled. Clean sewer mains by propelling snug fitting inflated rubber ball through the pipe with water. After completely cleaned, plug all pipe outlets with suitable test plugs. Brace each plug securely.

3.10.1.3 For pipe within test sections above the ground water table, add air slowly to the portion of the pipe installation under test until the internal air pressures is raised to the starting pressure of 4 psig. After the starting pressure is obtained, allow at least two minutes for air temperature to stabilize, adding only the amount of air required to maintain pressure. When pressure decreases to 3.5 psig. Start stopwatch. Determine the time that is required for the internal air pressure to reach 2.5 psig.

3.10.1.4 For pipe with test sections below the ground water table, determine the starting pressure for the test section, in psig, as follows:

1. Determine the maximum depth of pipe within the test section in feet.
2. Multiply this depth by 0.67 feet and add 9.3 feet.

3. Multiply the result in part 2 by 0.43 and round to the nearest 0.5 psig. After this starting pressure is obtained, continue the test in accordance with the procedure in the paragraph above.

3.10.1.5 Requirement: The test section shall be acceptable if the elapsed time for pressure drop of 1.0 psig is greater than the sum of the times shown below for all pipe sizes within the test section.

PIPE DIAMETER (INCHES)									
LENGTH	4	6	8	10	12	15	18	21	24
25	0:04	0:10	0:18	0:28	0:40	1:02	1:29	2:01	2:38
50	0:09	0:20	0:35	0:55	1:19	2:04	2:58	4:03	5:17
75	0:13	0:30	0:53	1:23	1:59	3:06	4:27	6:04	7:55
100	0:18	0:40	1:10	1:50	2:38	4:08	5:56	8:05	10:34
125	0:22	0:50	1:28	2:18	3:18	5:09	7:26	9:55	11:20
150	0:26	0:59	1:46	2:45	3:58	6:11	8:30	“	“
175	0:31	1:09	2:03	3:13	4:37	7:05	“	“	“
200	0:35	1:19	2:21	3:40	5:17	“	“	“	12:06
225	0:40	1:29	2:38	4:08	5:40	“	“	10:25	13:36
250	0:44	1:39	2:56	4:35	“	“	8:31	11:35	15:07
275	0:48	1:49	3:14	4:43	“	“	9:21	12:44	16:38
300	0:53	1:59	3:31	“	“	“	10:12	13:53	18:09
350	1:02	2:19	3:47	“	“	8:16	11:54	16:12	21:10
400	1:10	2:38	“	“	6:03	9:27	13:36	18:31	24:12
450	1:19	2:50	“	“	6:48	10:38	15:19	20:50	27:13
500	1:28	“	“	5:14	7:34	11:49	17:01	23:09	30:14

3.10.2 Corrective Measures: If elapsed time is less than the specified amount, Contractor shall locate and repair leaks and repeat the test until elapsed time exceeds the specified amount.

3.10.3 INFILTRATION/EX-FILTRATION TEST (Use All Manholes):

3.10.3.1 The use of this method for sewer pipe, in lieu of air tests may be used as an alternate test method.

3.10.4 Procedure:

1. Infiltration: Immediately following a period of heavy rain a test of work constructed up until the time shall be made. Three measurements shall be made at one (1) hour intervals to compute the amount of the infiltration. Test for manholes only shall be conducted on individual manholes. Tests for pipe and manholes shall be performed on test sections not exceeding 600 linear feet of collector sewer and shall include both pipe and manholes.

The Engineer reserves the right to use his judgment as to whether the ground is sufficiently saturated and/or whether the fall of rain is adequate to permit making infiltration tests. In the event that sufficient rain does not occur before the date of completion, the Contractor shall be required to conduct the tests at any time during a 30-day period following this date. Should the Engineer determine that certain pipe or manholes couldn't be tested by infiltration methods, the Engineer may direct the filling of lines and the measurement of ex-filtration. The allowable rate of ex-filtration shall be the same as for infiltration.

2. Ex-filtration: Determine test sections as outlined for infiltration tests. Install a temporary water plug at the inlet and outlet of the test section. Fill test section with clean water up to the bottom of the lowest manhole frame within the test section. Allow time for saturation of pipe and manholes refilling test section as required. Beginning with a full test section, allow at least eight (8) hours to elapse without adding water. Measure the water level at the beginning and end of the elapsed time above. Compute the volume of water lost in gallons per hour.

3.10.5 Test Requirements: The rate of water loss/gain shall be less than the rate, in gallons per hour, calculated for the test section using the following allowances:

1. Sewer main and manholes with or without service laterals; 100 gallons per 24 hours per inch of sewer main diameter per mile of sewer main (gpd/in-mil).
2. Manholes only; 1 gallon per 24 hours per vertical foot of manhole.

3.10.6 Corrective Measures: If actual leakage rate is greater than required leakage rate, Contractor shall locate and repair leaks and repeat the test until actual leakage is less than the required rate.

3.11 MEASUREMENT – PAYMENT:

3.11.1 Measurement and payment of pipelines: Measurement of pipelines shall be the actual number of lineal feet of pipe installed, complete in place and accepted. No deductions in length will be made for manholes. Pipelines shall be paid for at the unit contract price for each pipe size and depth of cut below the original ground over the pipe invert as shown on the plans and itemized in the Bid Schedule. The unit contract price for pipelines is to include stone bedding for the type of pipe material being bid. The unit price for pipelines also includes clearing and grubbing, pavement removal, shaping and seeding, traffic control and other related work.

3.11.2 Measurement and payment of precast manholes: The unit prices shall include furnishing and installing manhole steps, rings and covers and the construction of inverts.

Each manhole 0' – 6'0", measured vertically from the invert of the outlet pipe to the top of the manhole ring and cover casting will be paid for at the contract unit price for additional manhole depth. Payment will be made for the additional vertical feet of manhole installed above 6'0", measured to the nearest tenth of a foot.

PART 4 – FORCE MAIN SEWER

4.0 MATERIALS:

- 4.1 Ductile Iron Pipe: Shall be designed and manufactured in accordance with ASTM A-746 ANSI specifications A21.50, A21.51, and AWWA Standard C150 and C151 for laying conditions and shall be Class 250 unless otherwise specified on contract drawings.
 - 4.1.1 Pipe joints shall be of the push-on type as per AWWA C111. Pipe lining shall be cement mortar with a seal coat of bituminous material, all in accordance with AWWA C104.
 - 4.1.2 Exterior of all pipes shall be coated with either a coal or asphalted base bituminous pipe coating in accordance with ANSI specifications A21.8.
- 4.2 PVC Pipe: Shall meet the requirements of AWWA C900 and shall be manufactured in accordance with ASTM D-2241, latest edition, and shall be suitable for use as a sanitary sewer force main pipe. Pipe shall be Class 235, DR 18, integral bell with strength equal to the pipe wall, 18-foot length, with rubber "O" ring securely locked in place at point of manufacture.
 - 4.2.1 PVC Pipe: Force mains with a diameter of three (3) inches or less shall be SDR 21 or SCH 40 in accordance with ASTM D1785.
 - 4.2.2 PVC Pipe: Shall require the installation of a detector tape placed a maximum of 2 feet below the covering surface. Detector tape shall be 3 inches wide.
- 4.3 Pipe fittings shall be cast or ductile iron designed and manufactured as per AWWA C110. Sizes of fittings up to and including 12 inches shall be designed for a working pressure of 200 psi; larger size fittings shall be designed for a working pressure of 150 psi. Joints for fittings shall be mechanical joints and lined with cement mortar with a seal coat of bituminous material, all in accordance with AWWA C104.
- 4.4 Gate Valves: Shall be designed for a working pressure of 200 psi, unless otherwise specified, and shall have a clear waterway equal to the full nominal diameter of the pipe and shall be opened by turning clockwise. Each valve shall have the initials of the maker, pressure rating and year of manufacture cast on the body. Prior to delivery, each valve must be tested at twice the hydraulic working pressure. Gate valves larger than two (2) inch shall meet the requirements as set forth in AWWA C500.

5.0 INSTALLATION:

- 5.1 All components which are subject to hydrostatic thrust shall be reaction blocked by securely anchoring the items with concrete thrust blocks poured in place. No concrete shall interfere with the removal of fittings. Material for reaction blocking shall be 3000 psi concrete.
- 5.2 Sewage Combination Air Valves: Shall be installed at all high points along force mains. Manholes containing valves shall receive a bituminous or coal tar epoxy coating on the interior. The engineer shall determine size and valves shall be located at every high point.
- 5.3 Force Sewer Mains: Shall be installed in dedicated public right of ways or in dedicated utility easements.
- 5.4 Force Main Valve: Shall be spaced at appropriate intervals as determine by the City Engineer, and shall have valve box lids marked "Sewer." Force main valves shall be resilient wedge gate type.
- 5.5 Force Mains: Shall discharge in the invert of the receiving manhole and shall be 180 degrees from the outlet pipe.
- 5.6 Force Mains: Shall be appropriately identified upon installation to negate confusion with potable water lines. Pipe material shall be designated continuously along the length with the word "Sewer."

6.0 TESTING:

- 6.1 Force main material shall be placed and tested in accordance with water main standards.
- 6.2 All materials used must have a preliminary inspection by the Construction Inspector before materials are used for construction purposes. Rejections of material not meeting these specifications will be ordered and such materials shall be immediately removed from the job.
- 6.3 Sanitary sewer lines shall be free and clean from obstructions and shall be visually inspected from every manhole to ensure all lines exhibit a fully circular pattern. Lines that do not exhibit a true line and grade or have structural defects shall be corrected. Sanitary sewer service connections shall be visually inspected prior to back filling.
- 6.4 The Contractor shall furnish all materials, labor, and equipment to perform all testing to the satisfaction of the Construction Inspector. Water for testing purposes will be provided by the owner.
- 6.5 The low-pressure air testing shall be performed before all laterals or stubs are installed on the line and after the main has been backfilled to finish grade. Plugs shall be installed at each manhole to seal off the test section.

The line will be pressurized with a single hose and monitored by a separate hose connection from the plug. Air then shall be slowly introduced into the sealed line until the internal air pressure reaches 4.0 psi. The air pressure shall then be allowed to stabilize for a minimum of 2 minutes at no less than 3.5 (plus groundwater pressure, if any).

- 6.6 If the section fails to meet these requirements, the source of leakage shall be determined and repaired. The pipe section shall then be retested and meet the specified requirements.
- 6.7 The Construction Inspector may require that an infiltration test be performed that shall not exceed 100 GPD/inch/mile.

END OF SECTION

Section 02722-17

SECTION 02723 – LOW PRESSURE SEWERS

1. LOW PRESSURE SEWERS

Pressure sewer systems are permitted in the Hickory Service Area on a case by case basis and approved by the Public Utilities Administration Department. These areas will be situated on severe rolling terrain where gravity service would require lift stations. Material and construction specifications and standard details for pressure sewer connections are included in this section.

2. MATERIAL SPECIFICATIONS

Unless superseded or modified by an amendment or special provision, all materials and their method of manufacture shall conform to these specifications. Reference to any National Material Standard shall be latest revision.

The City of Hickory or Engineer may waive certain material requirements on case specific requests. The contractor may request to substitute material that has been specified. The Engineer, in writing, may accept or reject requests.

3. PUMPS AND WETWELLS

All low pressure sewer systems shall be uniform throughout the development. No variation in pump head curves will be allowed. Pumps shall be grinder type or positive displacement pumps supplied per manufacturers recommendations. Wetwells will be supplied with a minimum of 120 gallon storage capacity above the operating level. A complete package shall be one containing a siphon valve (for down hill pumps), installed outlet plumbing, control panel with alarm in a NEMA 4 watertight enclosure and pre-wired wetwell enclosed in a NEMA 4 watertight enclosure. Pumps and wetwells shall be as manufactured by Environment One Corporation and Myers.

4. PIPING

All pressure sewer piping shall be DIP or PVC as specified below. All pressure sewer shall be marked with detectable tape to the edge of the road right-of-way, including forcemain service connections. Detectable tape shall be green or brown tape printed with sanitary sewer as produced by Lineguard Maintenance System. In lieu of detectable tape, non-metallic piping shall be traced with a copper wire along the length and detector tape placed above along the length.

4.1 DIP

All DIP furnished shall be CL 350, conforming to ANSI/AWWA C-151/A21.51 and shall have a cement mortar lining as specified in AWWAC-104. DIP shall have push-on joints in accordance with AWWA C-111.

City Of Hickory

4.2 PVC

All four, six and eight inch pressure sewer may be PVC 1120, furnished in accordance with AWWA C-900, and shall be CL150 with a SDR of 18 or less, unless specified different on the construction drawings. All three inch and smaller sewer mains may be PVC 1120 furnished in accordance with ASTM D-2241, shall be CL160 with a SDR of 26 or less. PVC pipe shall be made from materials whose cell classifications are CL1245A or CL1245B. Pipe shall be supplied in 20 foot lengths. Shorter lengths are acceptable in cases to meet proper placement of fittings, valves, etc. All PVC pipe shall be delivered and stored so as that ultraviolet radiation exposure is no more than four (4) weeks.

Pipe joining shall be "elastomeric gasket joints" conforming to ASTM D-3139. Pipe three inch and larger shall have integral bells. No sleeve couplings will be allowed.

PVC pipe shall be replaced by DIP whenever it crosses or is within 18" of a water main. The DIP shall extend not less than ten (10) feet on each side of the water main.

5. FITTINGS

All fittings for pipe four inch or larger shall be ductile or cast iron. All fittings three inch or smaller shall be solvent weld PVC.

5.1 DUCTILE OR CAST IRON FITTINGS

All iron fittings shall be CL 250, mechanical joint, in accordance with AWWA C-110 or CL 350 compact fittings in accordance with AWWA C-153. All fittings shall be furnished bell and bell unless specified different by engineer. Fittings shall be cement mortar lined in accordance with AWWA C-104.

5.2 PVC FITTINGS

All PVC fittings shall be Schedule 80 in accordance with ASTM D-2467 and solvent weld joints installed with ASTM D-2855.

6. VALVES

All valves shall be plug or ball valves as specified. Valve operation shall be open left.

6.1 PLUG VALVES

All valves shall be eccentric plug valves as follows:

City Of Hickory

6.2.1 Plug valves shall be non-lubricated, with a plug facing as specified by the manufacturer for the application and shall have stainless steel permanently lubricated upper and lower plug stem bearings. Valves shall be designed with adjustable seals which are replaceable without removing the bonnet. Bearing and seal areas shall be protected with grit seals. Port opening for all valves shall be no less than 81% of full pipe area. Twelve inch and smaller valves shall be pressure rated to 175 psi. Fourteen inch and larger valves shall be pressure rated to 150 psi. Shut offs shall be bi-directional.

Plug valves shall be as manufactured by Dezurik Corporation, Milliken Valve Company, Keystone Valve, or approved equal.

6.2.2 Four inches and larger or as specified shall have mechanical joint ends as per ANSI A21.11 for buried valves.

6.2.3 Three inches and smaller buried valves shall have Schedule 80 threaded ends and shall be connected to the main by Schedule 80 PVC threaded by socket adapters.

6.3 Buried plug valves shall have two inch operating nuts within 10 to 15 inches below finish grade.

6.3.1 All accessories shall be supplied as specified by manufacturer.

6.3.2 Buried plug valves shall be provided with adjustable valve boxes. Valve boxes shall be cast iron conforming to ASTM A-48, CL30. Valve boxes shall be Tyler 462A or approved equal.

6.4 THERMOPLASTIC BALL VALVES

Thermoplastic ball valves shall be used at each service connection and shall be made of PVC thermoplastic. Valves shall be furnished with Teflon seats and true union threaded ends. Thermoplastic ball valves shall be as manufactured by Heyward, Incorporated or approved equal.

6.4.1 THERMOPLASTIC BALL CHECK VALVES

Check valves shall be located and specified as above. The valves shall be furnished with elastomeric seats and true union threaded ends.

7. SERVICE BOXES AND LIDS

All service connections and cleanouts shall be placed in an appropriately sized box, as depicted in the standard details, and shall be as manufactured by Brooks Products Company (36 series) or approved equal.

- 7.1 Concrete boxes shall be made from a concrete of 1:2:1, cement to granite screening to 3/8" granite stone. Meter boxes shall be machine made and tamped with pneumatic tamps. Concrete shall be steam cured for 24 hours and yard cured for two (2) weeks.

All service connection boxes shall be made of green plastic and sized as in the standard details for thermoplastic material using structural foam as manufactured by Brooks Products Company (Series 1730). The plastic shall be uniform and suitable for outdoor, buried application. Plastic lids shall be furnished with "snap-lock" tabs and be imprinted with the words "pressure sewer" on the lid.

CONSTRUCTION SPECIFICATIONS

8. INSTALLATION OF PVC LOW PRESSURE PIPE

PVC pressure sewer main shall be installed substantially in accordance w/ the standard recommended practices for Underground Installation Of Flexible Thermoplastic sewer pipe ASTM D-2321.

8.1 INSTALLING VALVES AND FITTINGS

Valves and fittings shall be installed in the manner specified for cleaning, laying and jointing pipe. Valves shall be installed at locations shown on the plans and/or as directed by the Engineer.

9. VALVE BOXES

A valve box shall be installed at every buried plug valve. The valve box shall not transmit shock or stress to the valve and shall be centered and plumb over the operating nut with the box cover flush with the pavement or other existing surface. The valve box shall be bedded in stone and flush with the existing terrain. The location at the valve will be identified by the letters "P.S.V." imprinted onto the curb adjacent to the valve.

10. ALIGNMENT AND GRADE

Unless specifically approved by the Engineer, the curb be in place and backfilled, and the area between curb and street right of way line graded smooth and to finish grade before the pressure sewer mains are installed. Pressure sewer shall be placed on the opposite side of the road from H₂O and 3-5 feet behind curb where specified different by the Engineer in approved plans. Pressure sewer may be installed before curbing if a written request is made and approved by the Engineer and Public Utilities Administration and all comments are abided by. Installation before curbing will be field verified and deficiencies rectified at the contractor expense.

11. DEPTH OF PIPE INSTALLATION

Tap or pipe shall be 5.0 (min.) below the edge of adjacent roadways or 4.5' (min) below finish ground unless specified different by the Engineer or approved plans.

The Contractor may be required to vary the depth of pipe to achieve minimum clearances from existing utilities and maintain the above minimum cover requirements. Existing utilities spotting is responsibility of Contractor. PVC pressure sewer shall be installed with 18" clearance above or below existing utilities.

The test pressure will be 100 psi at the low point at the section under test.

Allowable leakage will be determined by Table 6, AWWA C-600 or by the formula:

$$L = .000083(S)D,$$

where S is the length of pipe under test and D is the pipe diameter. Add .0050 gal/1hr for each 1-1/2" lateral.

Finally, without reduction in pressure progressing from the end opposite the test pump, each mainline valve will be closed and pressure released to determine if the valve is holding pressure.

11.1 1.5" SERVICE CONNECTIONS

On 3- inch and smaller mains, the 1.5" laterals shall be connected to the street main with schedule 80 PVC solvent weld wyes. On 4-inch and larger mains, the 1.5 inch laterals shall be connected to the street main with a MJ tee plugged and tapped for a threaded by solvent weld schedule 80 PVC Adaptor. The 1.5" service lateral shall be completed to the property line where a service connection meter box shall be installed. The service connection shall contain the following fittings in accordance with the Standard Details, 45 degree solvent weld elbow, solvent weld nipple, solvent weld by threaded adapter, two true union threaded ball valves, threaded 1.5" x 1.5" x 1.5" tee, threaded adapter, threaded nipple, true union ball check valve, threaded x solvent weld nipple. 1.5" x 1.25" solvent weld reducing bushing and a brass .75" hose bib placed on top of the 1.5" tee.

11.2 PARTIAL SERVICE CONNECTIONS

Partial service connections shall be installed according to the Standard Details at the locations indicated on the Plans. The location for this future service connection stub-out shall be marked by cutting an "S" on the curb above the service. Also, a PVC encapsulated magnet shall be attached near the valve and cap for magnetic locating purposes.

12. DESIGN OF PRESSURE SEWER SYSTEMS

The developer shall have all pressure sewers designed by a professional engineer licensed in North Carolina. The Engineer shall submit preliminary design and calculations to Public Utilities Administration for review before initiating final design. All head and pressure calculations shall be submitted in tabular form for each branch. In addition to drawings and specifications, the developer shall include a design memorandum detailing the design procedures used for the pressure sewer system. The design memorandum shall include:

- 12.1 Hydraulic calculations demonstrating that the total dynamic head (TDH) does not exceed 100 feet at any existing or potential grinder pump location.
- 12.2 Profiles of all pressure sewer lines demonstrating that the system will be under positive pressure sewer lines demonstrating that the system will be under positive pressure at all time. Specifically, the discharge elevation shall be above all intervening high points.
- 12.3 Calculations indicating determination of pressure main sizing. Initial pipeline sizing shall be based on providing a minimum of 3.0 foot per second (fps) velocity at a discharge calculated according to the following equation:

$$Q \text{ (in gpm)} = 15 + 0.5D$$

where: D = The number of dwelling units upstream of the reach under investigation.

- 12.4 Calculation of final pipe size may be adjusted based on evidence from hydraulic calculations, provided that such calculations indicate that a minimum of 2.0 fps can be achieved in all lines with no more than 5% (or minimum of 2) pumps operating simultaneously through the line under determination.
- 12.5 Determination of Hazen-Williams coefficient. A Hazen-Williams coefficient, C, of 140 to 150 may be used, provided that if C=150, the nominal pipe size only may be used, and an allowance for minor losses associated with fittings should be included in the hydraulic calculations.

City Of Hickory

- 12.6 Calculation of Impeller Diameters for each pump. The impeller diameter of individual pumps in a system with varying pump elevations shall be sized such that full size impellers are used at pumps at the lowest elevations, and reduced size impellers are used at higher pumps such that the total TDH of any one pump is within 20% of all other pumps.
- 12.7 Calculations of the maximum flow discharged from the pressure sewer system with all pumps operating. This condition will be experienced upon restoration of power following a system wide power outage. If the maximum flow calculated, including other pressure sewers, exceeds the rated maximum pumping capacity of any downstream pump stations, the discharge shall be into a gravity sewer of sufficient diameter and length to provide 150 gallons of storage capacity per grinder pump within the gravity pipeline. All gravity sanitary sewers shall be constructed in accordance with the Requirements and Specifications for Sanitary Sewer Construction.
- 12.8 Private pressure sewers shall connect to the City of Hickory maintained system at a stub from the property line side of the dual ball valve/check valve assembly according to the service connection Standard Details (See Pressure Sewer Material Specifications).
- 12.9 Engineers must submit a copy of all preliminary design calculations to the City of Hickory Public Utilities Administration before plans and specifications are submitted.
- 12.10 Owners/Developers shall include a list of possible licensed plumber's who may be contracted to maintain the internal network, pump assemblies, and appurtenances. A contracted licensed plumber will be required for service.

END OF SECTION

SECTION 2900 – RESTORATION OF SURFACES

1.1 INTRODUCTION

The scope of this section is to furnish all labor, equipment and materials necessary for the proper restoration of existing surfaces disturbed or damaged as a result of any construction activity not specifically detailed for other landscaping or restoration in any other part of this specification. Any damage to existing surfaces or structures shall be restored to original condition or better using like materials and workmanship to the original.

1.2 INSTALLATION

All pervious surfaces shall be dressed smooth and seeded in strict accordance with the section of these specifications entitled Seeding and Landscaping. Shoulders of all roads shall be restored as specified for lawns. Wooded areas or fields shall be restored raked smooth and seeded as specified in the section entitled Seeding and Landscaping.

A. Ditches:

Ditches shall be regarded to the original grade or such grade that flow is maintained to prevent ponding or standing water. If the grade must be altered, the Engineer shall approve the final grade and all adjacent slope grades with the Contractor performing the work as directed by the Engineer. The surface of all ditches shall be returned to the same condition as found before commencing work. The unit price for this work shall be encumbered in pipeline installation prices.

B. Concrete Walks:

Concrete walks removed or damaged as a part of the construction operation shall be replaced with new Class B concrete formed and poured in place and installed to match the original line, grade and general appearance of the existing walk. Concrete shall be poured to match the original walk thickness, but not less than 4” thick, over a thoroughly compacted and leveled sub grade. Walks shall be float finished, edged with an edging tool and grooved at intervals to match the existing walk, or at intervals not exceeding the width, uniform throughout the length of the replacement measured in one direction. This work shall be paid at unit price.

C. Driveways

Concrete drives removed or damaged as a part of the construction operation shall be replaced with new Class B concrete formed and poured in place and installed to match the original line, grade and general appearance of the existing drive. Concrete drives shall be poured the same thickness of the original drive, but not less than 4” thick, and shall contain reinforcing steel, mating, etc. to match the original drive. Prior to placing the concrete a 4” aggregate base course shall be placed in the drive area and leveled. The Contractor shall be responsible for coordinating restoration with property owner and allowing for curing time.

Bituminous or Asphaltic concrete drives shall be restored to the original base and asphalt thickness. As a minimum, all bituminous or asphaltic concrete drives shall consist of 6" base course and 2" surface material. Base material shall be thoroughly compacted and leveled to provide the appropriate depth of support and surface material shall be compacted in 2" lifts and topped with the appropriate depth to match the existing surface grade. All work done under this provision shall be performed in accordance with the section entitled Bituminous pavement Repairs. The Contractor shall be responsible for coordinating restoration activities with the property owners.

All unpaved drives shall be surfaced with not less than 4" of Crusher-run gravel and topped with similar surface material as the existing drive. The final drive shall consist of the 4" base and not less than 3" of surface material to match the existing drive. All unpaved drives shall be restored to a condition better than the original when encountered.

All drives shall be temporarily replaced with 4" of Crusher-run installed level with the existing drive surface and maintained until such time as the permanent drive can be restored. Restoration should not take more than three weeks without approval from the Engineer/Owner.

D. Roadway Replacement

Bituminous or Asphaltic pavements shall include all areas paved with blacktop; built-up pavements, oil and stone, tar and stone or any similar pavements constructed with a bituminous or asphalt and stone material.

Immediately upon completion of installation of underground piping and structures, the trench shall be backfilled and compacted to specification and roadway shall be repaired. The excavated area shall be restored to match the original material. In the case of tar and stone, oil and stone or other unprocurable material the repair shall consist of asphalt repair. The repair shall consist of a 12" aggregate base course, and a 4" surface course as defined in the specification entitled Bituminous Pavement Repairs. If Engineer deems appropriate then the Contractor may be allowed to surface treat damaged pavements outside of the excavation without removal of existing surface and base courses by overlaying the area in question and matching back to the existing surface.

Portland cement concrete road surfaces shall be replaced with Class B concrete and shall have equal thickness and reinforcing steel as the original roadway. Prior to placing concrete an aggregate base course of 6" thickness shall be placed and compacted.

The Contractor shall repair or replace any and all traffic markings damaged, removed or covered during construction. All existing manholes or valve covers shall be raised to finished grade prior to paving to prevent covering of existing infrastructure. The Contractor shall include this work as a part of the project and shall not seek additional compensation outside of the original unit prices. All such inquiries shall be requested and approved by the Engineer.

All differential settlement shall be corrected immediately as directed by the Engineer and the Engineer shall approve corrections.

All work under this category shall be performed in accordance with NCDOT Standards and shall be subject to inspection by the local representative for conformance with the requirements and specifications.

E. Lawns and Landscaped Areas

All lawns and disturbed area shall be regarded to match the existing grade prior to construction. Lawns, as previously defined, shall be graded, seeded and fertilized in strict conformance with the section of this specification entitled Seeding and Landscaping. Top soiled areas shall be replaced with topsoil of equal or better quality and quantity.

All shrubs, hedges, ornamental trees, flower or other items constituting landscaping shall be replaced to the original condition with the same items as removed or similar materials at property owner's approval.

F. Curb and Gutter

Curb and gutter sections removed, damaged, destroyed or otherwise impacted by the construction operation, Contractor or his agents shall be replaced with new Class B concrete to a condition matching or similar to that existing before construction activities. If curb and gutter cannot be matched exactly to the original condition, the Engineer shall approve alteration.

G. Damage to any Structure

All damage to existing structures shall be repaired by materials and workmanship equal to the original construction. At the direction of the Engineer, sufficiently damaged structures may require total replacement to the extent deemed appropriate by the Engineer. The Engineer shall approve all such replacements and unless otherwise noted separate payment for the repair or replacement will not be allowed.

END SECTION

SECTION 2930 – SEEDING AND LANDSCAPING

1.1 INTRODUCTION

This section covers the furnishing of all labor, equipment, material and any other items necessary for landscaping of all areas of the site disturbed by construction operations and all earth surfaces of embankments including rough and fine grading, topsoil if required, fertilizer, lime, seeding and mulching. The Contractor shall adapt his operations to variations in weather or soil conditions as necessary for successful establishment and growth of grasses or legumes.

1.2 CATALOG CUT SUBMITTALS

Contractor shall submit 4 copies of catalog cuts to Engineer for review for all materials that are required to complete the work as described in the associated plans. Engineer will retain two sets of original submittals and return two sets to the Contractor with the appropriate response annotated.

1.3 STORAGE AND HANDLING

Contractor shall take all prudent and customary measures to ensure that all materials stay moisture free and are not degraded by storage or handling. All lime and fertilizer shall be kept free from hardening or caking and if this occurs they shall be pulverized to their original state. All seed shall be further protected such that it is not subjected to heat or rodents. If degradation occurs and the materials no longer hold the mineral values advertised then they shall be removed from the site and new materials applied.

1.4 MATERIALS

A. Lime

The quality of lime and all operations in connection with the furnishing of this material shall comply with the requirements of the North Carolina Lime Law and regulations adopted by the NC- Board of Agriculture.

Lime shall be agriculture grade ground dolomite limestone. It shall contain not less than 85% of the calcium and magnesium carbonates and shall be of such fineness that at least 90% will pass a No. 10 sieve and at least 50% will pass a No. 100 sieve.

B. Fertilizer

The quality of fertilizer and all operations in connection with the furnishing of this material shall comply with the requirements of the North Carolina Fertilizer Law and regulations adopted by the NC- Board of Agriculture.

Fertilizer shall be 10-10-10 grades. Upon written approval of the Engineer a different grade of fertilizer may be used, provided the rate of application is adjusted to provide the same amounts of plant food.

C. Seed

The quality of seed and all operations in connection with the furnishing of this material shall comply with the requirements of the North Carolina Seed Law and regulations adopted by the NC- Board of Agriculture.

The NC-Dept. of Agriculture shall have approved seed or any agency approved by the Engineer before being sown, and no seed will be accepted with the date of test more than 9 months prior to the date of sowing. Such testing does not relieve the Contractor from responsibility for furnishing and sowing seed that meets these specifications at the time of sowing. When a low percentage of germination causes the quality of seed to fall below the minimum pure live seed specified, the Contractor may elect, subject to approval of the Engineer, to increase the rate of seeding sufficiently to obtain the minimum pure live seed contents specified, provided that such an increase in seeding does not cause the quantity of noxious weed seed per square yard to exceed the quantity that would be allowable at the regular rate of seed.

Seed shall be entirely free from bulbets or seed of Johnson Grass, Nutgrass, Sandbur, Wild Onion, Wild Garlic and Bermuda Grass. The specifications for restricted noxious weed seed refers to the number per pound, singly or collectively, of Blessed Thistle, Wild Radish, Canada Thistle, Corncockel, Field Bindweed, Quackgrass, Didders, Dock, Horsenettle, Bracted Plantain, Buckhorn or Wild Mustard; but in no case shall the number of Blessed Thistle or Wild Radish exceed 27 seeds of each per pound.

D. Mulch

Straw shall be free of weed seed or any other species, which would be detrimental or deterring to specified grass maturation. Straw shall be from oat, rye or wheat species and threshed to limit seed content.

E. Tack

Emulsified asphalt or organic tack shall be applied uniformly over straw so as to ensure proper hold and give uniform appearance over the entire area. Tack shall be applied by spraying onto surface immediately after applying straw. Application rates will vary dependent upon conditions. Organic tack shall be used when the ambient temperature is below freezing

1.5 PREPERATION

A. Protection of Existing Vegetation

The Contractor shall not remove or damage vegetation, which is outside the Clearing Limits established by the Owner/Engineer or as displayed on the plans. All trees that are damaged and scheduled to remain shall be repaired in an acceptable manner promptly to prevent progressive deterioration. Vegetation which is scheduled to be replaced or is damaged beyond repair during construction operations shall be replaced with a similar size and species. Where this is not feasible the property owner shall be compensated for the vegetation damaged. Damage incurred during construction operations and due to insufficient protection shall be paid at the Contractors expense.

Existing vegetation not indicated for removal shall be protected against unnecessary cutting, breaking or skinning of roots, skinning or bruising of bark or smothering of vegetation by placing stockpiles of excavated material against the trunk or excessively over roots within the drip line. Vegetation shall also be protected against excessive vehicle or foot traffic within the drip line.

Roots cut during excavation shall be properly protected by either asphalt sealing or in some cases wrapping exposed roots in wet burlap to prevent drying.

B. Grading

Rough grading of the area shall be achieved as soon as the excavated area is backfilled and compacted. Rough grading shall be defined as all material restored which is required to bring the area to finish grade and acceptable surface drainage for storm water which provides for water to flow from the site in such a manner as that it does not place unusual risk to unsuspecting users of adjacent areas or inhabitants.

Fine grading of the area shall be achieved in a timely manner after completion of rough grading of the area. Fine grading shall consist of shaping final contours to ensure proper drainage and removing all debris or construction waste materials to provide an acceptable appearance. Construction area subject to finish grading shall have soil loosened to a depth of not less than 6 inches in a manner approved by the Engineer to promote seed growth. All finish landscaping shall be completed on a section-by-section basis where it is reasonable to expect completion of landscaping.

All grading, landscaping, and erosion control measures shall be properly pursued and maintained in order to maintain and acceptable appearance of the project. If such time occurs as this perception is degraded then the Engineer may suspend progress on the project until the issues are appropriately addressed.

C. Surface and Bed Preparation

The Contractor shall smooth or shape surface contours outside the project site when such contours are detrimental to the seedbed preparation or will pose foreseeable problems with future maintenance of the area. The Engineer shall direct the Contractor to what extent outside areas shall be affected or the Contractor may elect to work with individual property owners with written verification delivered to the Engineer/Owner of the agreement with the property owner's signature.

1.c Level Areas and Slopes Less than 2:1

The construction area shall have soil loosened to a depth not less than 6 inches and shall be free from all debris, clods and all other irregularities which would prohibit a smooth, shaped finish grade. Top 3 inches of soil shall be worked to a clod free finish suitable for planting seed.

2.c Slopes Greater Than 2:1

The construction area shall have soil loosened and acceptable for vegetation growth but the surface shall be free from all debris, clods and other irregularities. The surface may be track finished, scarified, grooved or punctured so as to provide a place for seed and other planting material to lodge. In the case of such slopes the Engineer may allow partial completion of the slope sections at different times to promote stabilization. If the vegetation growth is acceptable the Engineer may allow this to remain as the permanent ground cover.

The Contractor shall not pursue the finished preparation of surface areas to be landscaped if the soil is frozen, marginally wet or when the Engineer deems it unsuitable for working conditions.

D. Rate of Application

Seed shall be applied by means of Broadcast Spreader, Hydro-Seeder or other previously approved method. In no case shall seed, lime, or fertilizer be spread by hand. The rates of application for seed, lime and fertilizer shall be as follows, unless a variance is permitted by the Engineer in writing prior to performing work.

1.d Limestone

In the absence of a soil test performed at the Contractors expense and given to the Engineer on letterhead from the testing laboratory, Limestone shall be applied at the rate of 2000 lb/ acre.

2.d Fertilizer

In the absence of a soil test performed at the Contractors expense and given to the Engineer on letterhead from the testing laboratory, Fertilizer shall be applied at the rate of 1000 lb/ acre. Fertilizer shall be 10-10-10 grade, unless a variance is permitted by the Engineer in writing prior to performing work. A second application at 500-lb/ acre shall be applied to the area when the grass has reached a blade height of 3 inches or 45 days which ever comes first.

3.d Seed

The type and rate of application shall vary at different times of the year and shall be applied at the rate and type appropriate for the time of year. All rates of application are measured in pounds per acre.

a. Fall and Winter (Sept. 1 to May 1)

85 pounds of Ky-31 tall fescue mixed with 15 pounds of rye grain.

b. Spring and Summer (May 1 to September 1)

100 pounds of Ky-31 tall fescue mixed with 10 pounds of rye grain.

c. Cut of Fill slopes greater than 2:1

The application rate on cut or fill slopes greater than 2:1 shall include the appropriate mix above for the time of year along with; 40 lb/acre of sericea lespedeza (hulled in spring or summer and unhulled in fall and winter) and either 15 pounds of Sudan grass in spring and summer or 25 pounds of rye cereal per acre in fall and winter.

4.d Mulch

Mulch shall be straw mulch applied at a rate of approximately 3000 pounds per acre. Straw shall be applied at such rate necessary to thoroughly cover and protect all finish grading, seed, lime and fertilizer but not smoother the maturation of seed.

E. Application

Application of all limestone, fertilizer, seed and mulch shall be completed immediately following final preparation of the seed bed and shall not be pursued during a time when the Engineer deems weather to be non-conducive for seed growth, i.e. ground wet, frozen, etc. Lime, fertilizer and seed shall be distributed uniformly over the prepared seedbed at the specific rate of application and then harrowed, raked, or otherwise thoroughly worked or mixed into the seedbed. Immediately following the covering operation, the seedbed shall be properly compacted as directed in the manner and degree approved by the Engineer.

When a hydraulic seeder is used for application of seed and fertilizer, the seed shall not remain in water containing fertilizer for more than 1 hour prior to application unless otherwise permitted by the Engineer.

The Engineer may permit modifications to the requirements for covering or compacting lime, fertilizer and seed in the prepared seedbed if the Contractor requests modification due to height, steepness of slope or non-conductive soil conditions. Modifications may be considered in the case of: Slopes greater than 2:1 and Slopes where surface is too rocky to successfully permit compaction or covering of the seedbed. Modifications may be permitted to include reduction of application rates and reduction or elimination of compaction requirements.

All equipment normal and prudent for the preparation of seedbed and uniform distribution of lime, fertilizer and seed shall be approved by the Engineer prior to use on the project. In the event of malfunctioning or improperly maintained equipment, the Engineer reserves the right to suspend work on the project until such time as the equipment is restored to good repair and properly operational.

F. Mulching

Mulch shall be spread uniformly over all seeded areas at a rate of 1 ½ to 2 tons per acre in a continuous, uniform blanket. Mulch shall be spread by hand or by approved mechanical shredder or blower which will provide a uniform blanket. An acceptable application shall be one that completely covers the ground but still allows some sunlight to penetrate and air to circulate while providing effective soil moisture conservation and reduced erosion. Mulching operation shall be pursued immediately following final seedbed preparation.

Tack or other approved binding material shall be applied over top of mulch in all necessary areas to ensure mulch will be held in place during adverse conditions. The rate and method of application shall be completed as directed by the Engineer.

The Contractor shall implement sufficient precautions to prevent mulch from entering drainage structures through displacement by wind, water or other causes. The Contractor shall remove completely any blockage to drainage structures, which may occur.

G. Maintenance

Grassed areas shall be accepted when a 95% cover of permanent grasses is achieved and weeds are not the dominant foliage. The Contractor shall keep all grassed areas in good condition, reseeding and mowing if and when necessary as directed by the Engineer. A good lawn shall be established over the entire project area and shall be maintained by the Contractor in an approved manner and kept in an approved condition until final acceptance.

The Contractor shall protect against washouts on slopes and ditch sections by a manner approved by the Engineer. Any damage or failure due to any cause shall be corrected by being either repaired or completely redone as may be directed by the Engineer. Areas of damage or failure resulting either from negligence on the part of the Contractor in performing construction operations or from not taking sufficient precautions to control erosion and silt as required throughout the various sections of the specifications, shall be repaired by the Contractor as directed by the Engineer at no cost to the Owner.

End of Section

Engineering Department
Manual Of
Practice



Life. Well Crafted.

700 Landscaping

DIVISION 700 LANDSCAPING

A. GENERAL NOTES

1. Areas within buffers not covered by screening devices shall have permanent ground cover established. Ground cover shall include seeded grass or sod, low growing evergreen or shrubs, rock, brick or wood mulch or any combination.
2. All planting which materially impairs vision between 2 ½ and 8 feet in height shall be sited outside of intersection sight triangles.
3. Areas within easements or right-of-way limits that are unpaved shall have permanent ground cover established prior to the City accepting the construction or development. Seeded vegetation shall be established on a mowable surface. Areas presently wooded shall be retained and restored.
 - (a) Seeding specs shall be based on proposed planting season and vegetation needs.
 - (b) Soil tests should be performed to determine the proper amount of fertilizer and soil amendments required.
 - (c) Areas shall be ripped and spread with available topsoil minimum 3" deep. Total seedbed prepared depth shall be 4" to 6" deep or as required.
4. The planting season for the Hickory Area generally extends from November 15th until April 15th of the following year.
5. The following list is the recommended distances for planting trees around obstacles.

Plant Tree:	5 feet from water meters
	15 feet from fire hydrants
	20 feet from utility poles
	25 feet from driveways
	Outside the required intersection sight triangle

When planting directly under overhead power lines use a tree with a mature height of less than 20 feet.

B. PLANTING LIST

This list indicates plantings which will meet the screening and buffer requirements of the zoning ordinance. This list is by no means comprehensive and is intended merely to suggest the types of flora which would be appropriate for screening and buffer purposes. Plants were selected for inclusion of the list according to three principal criteria: general suitability for the climate and soil conditions of the area, ease of maintenance, and availability from area nurseries.

NOT TO SCALE

	CITY OF HICKORY	
	GENERAL NOTES FOR LANDSCAPING	SHEET 1 OF 1
	DATE: 2-1-07	STD. NO. 701

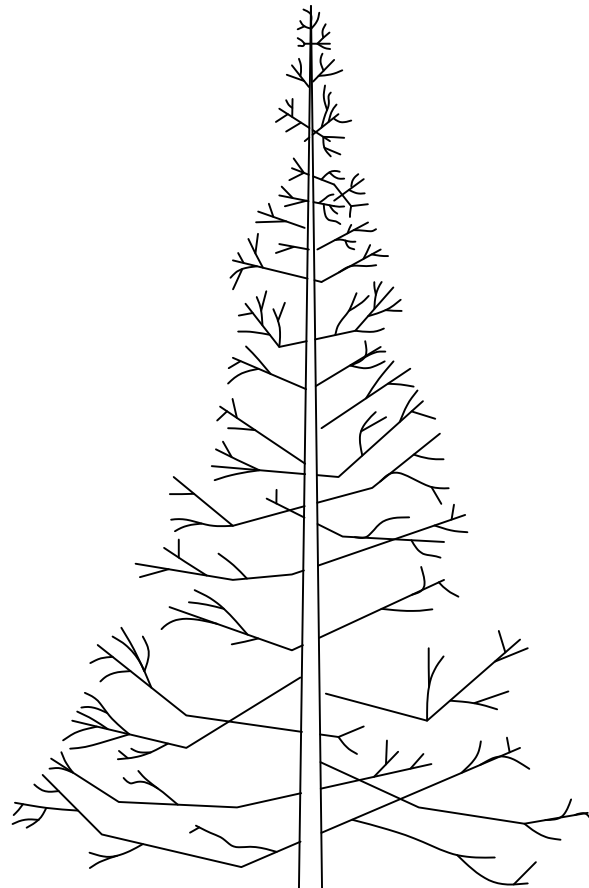

RUBBER HOSE
 SECURED WITH NO.12 GAUGE
 PLIABLE DOUBLE STRAND WIRE
 (AS NEEDED)

STAKES AS SPECIFIED
 DRIVEN 3'-0" IN
 GROUND, TWO
 STAKES PER TREE

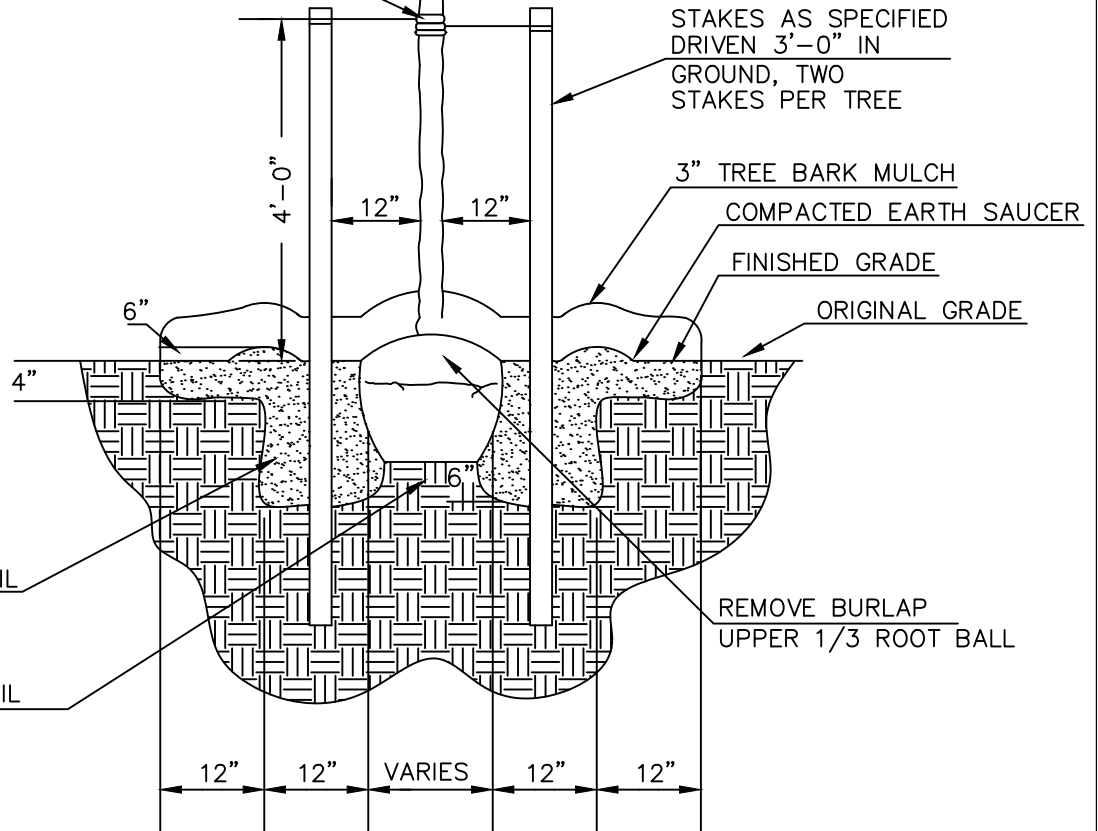

AMENDED TOPSOIL

UNDISTURBED SOIL
 PEDESTAL

REMOVE BURLAP
 UPPER 1/3 ROOT BALL

NOT TO SCALE



CITY OF HICKORY

PLANTING SMALL TREES
 UP TO AND INCLUDING 2 INCH CALIPER

SHEET 1 OF 1

DATE:
 2-1-07

STD. NO.
 702

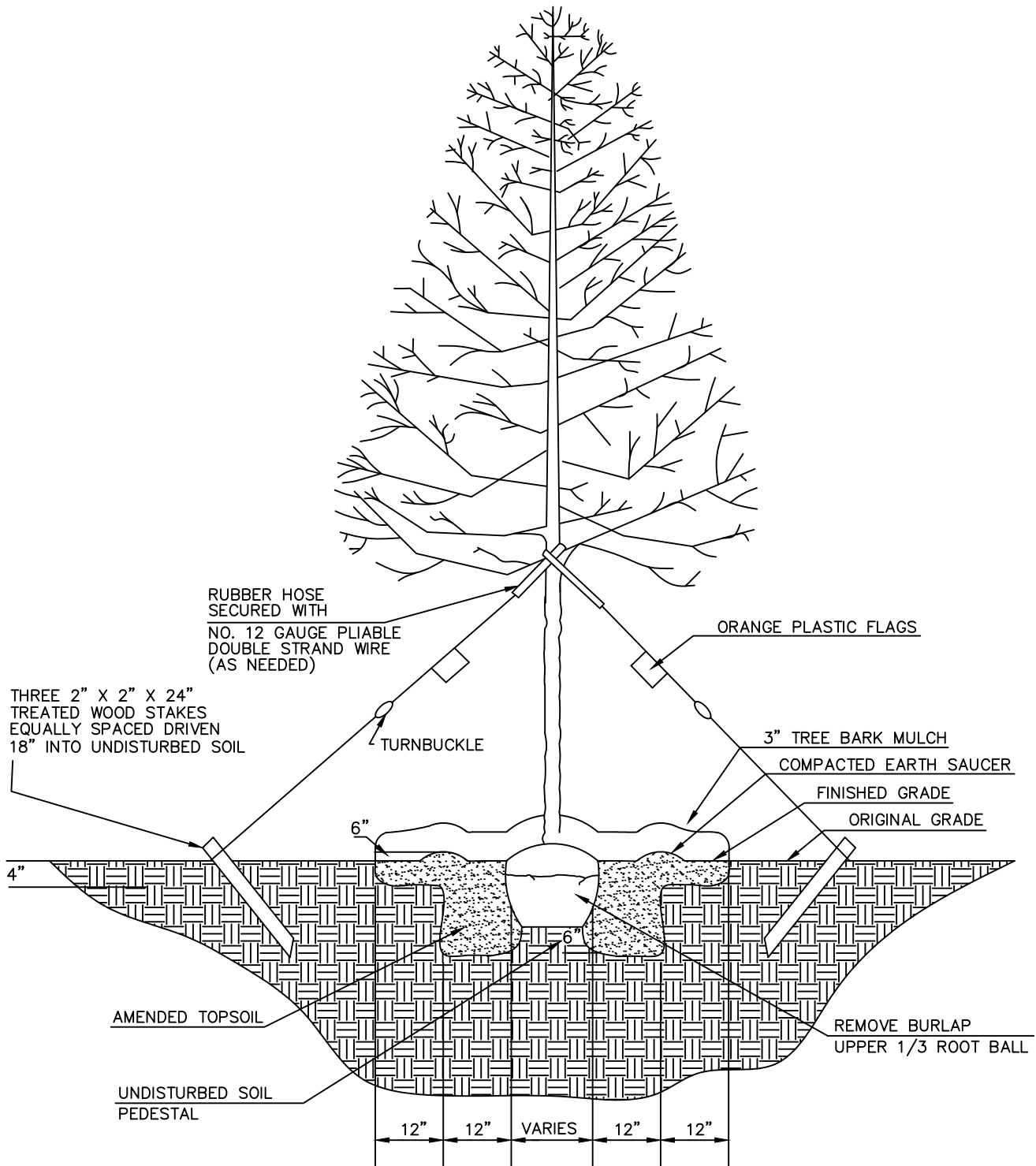

NOT TO SCALE



CITY OF HICKORY
 PLANTING LARGE TREES
 GREATER THAN 2 INCH CALIPER

DATE:
 2-1-07

SHEET 1 OF 1
 STD. NO.
 703

Engineering Department
Manual Of
Practice



Life. Well Crafted.

800 Solid Waste

DIVISION 800 SOLID WASTE

A. GUIDELINES FOR CITY-MAINTAINED ROADS IN SUBDIVISIONS

- For townhomes, rollout trash receptacles can not be on both sides of the road. They must all be on the same side of the road.
- Ultimately, the decision for any solid waste matter is up to the discretion of the solid waste manager, city planner, or engineer.

NOT TO SCALE



CITY OF HICKORY

GENERAL NOTES FOR
SOLID WASTE

SHEET 1 OF 1

DATE:
05-25-23

STD. NO.
801

THE WALL SHALL BE CONSTRUCTED IN A DURABLE FASHION OF WOOD, METAL, BRICK AND OTHER MASONRY MATERIALS OR A COMBINATION THEREOF AS APPROVED BY THE PLANNING DIRECTOR. IF THE ENCLOSURE IS VISIBLE FROM A PUBLIC STREET, THE WALL AND GATE SHALL BE ARCHITECTURALLY COMPATIBLE WITH OTHER BUILDINGS AND STRUCTURES ON THE SITE.

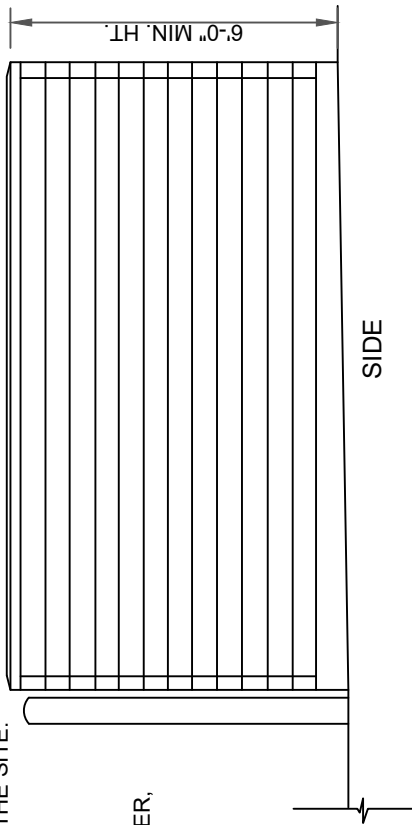

CONCRETE PAD NOTES
 1. MINIMUM 6" CONCRETE WITH 6X6 W2.0XW2.0 WWF ON 6" ABC BASE

6" DIA. STEEL HINGE POSTS PROVIDED BY GATE MANUFACTURER, FILL WITH CONCRETE WITH DOMED TOP

DRILL HOLES IN CONCRETE TO RECEIVE CANE BOLT, INSTALL PVC SLEEVE, TYPICAL AT EACH DOOR

GATE FRAME, HINGES AND DECK FACING PROVIDED BY GATE MANUFACTURER

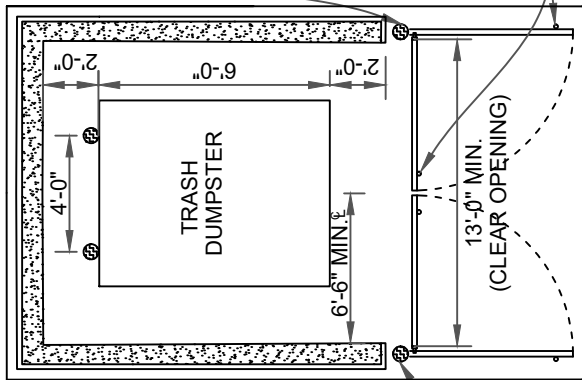

PLAN

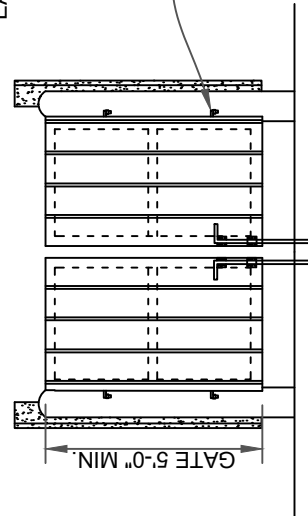

FRONT

NOT TO SCALE



CITY OF HICKORY

SINGLE DUMPSTER PAD

DATE:
5/18/2022

SHEET 1 OF 1
 STD. NO.
802

THE WALL SHALL BE CONSTRUCTED IN A DURABLE FASHION OF WOOD, METAL, BRICK AND OTHER MASONRY MATERIALS OR A COMBINATION THEREOF AS APPROVED BY THE PLANNING DIRECTOR. IF THE ENCLOSURE IS VISIBLE FROM A PUBLIC STREET, THE WALL AND GATE SHALL BE ARCHITECTURALLY COMPATIBLE WITH OTHER BUILDINGS AND STRUCTURES ON THE SITE.

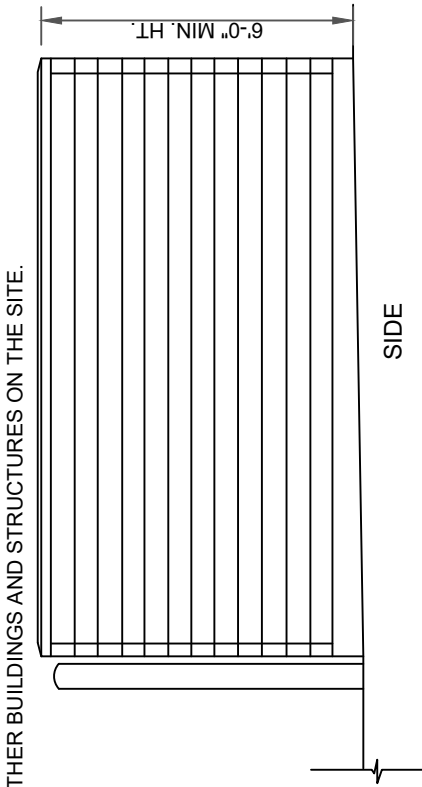

SIDE

CONCRETE PAD NOTES
 1. MINIMUM 6" CONCRETE WITH 6X6 W2.0XW2.0 WWF ON 6" ABC BASE

GATE HARDWARE INCLUDING HINGE POSTS, HINGES AND CANE BOLT ASSEMBLY PROVIDED BY GATE MANUFACTURER

6" DIA. STEEL HINGE POSTS PROVIDED BY GATE MANUFACTURER, FILL WITH CONCRETE WITH DOMED TOP

GATE FRAME, HINGES AND DECK FACING PROVIDED BY GATE MANUFACTURER

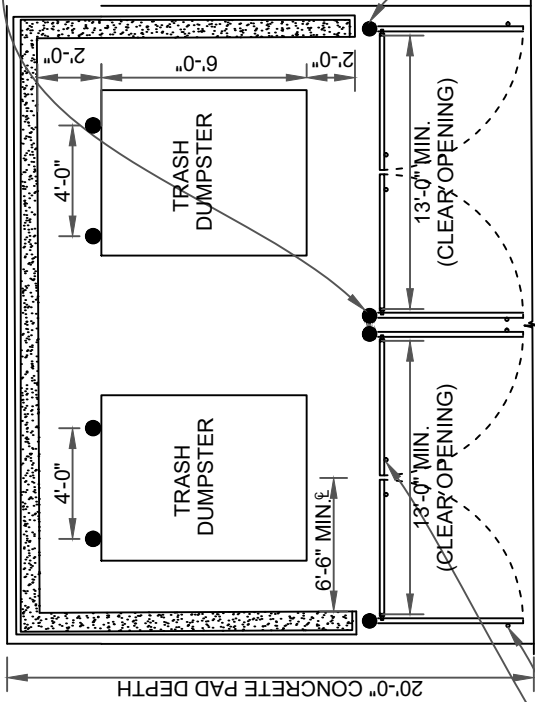

PLAN

DRILL HOLES IN CONCRETE TO RECEIVE CANE BOLT. INSTALL PVC SLEEVE, TYPICAL AT EACH DOOR

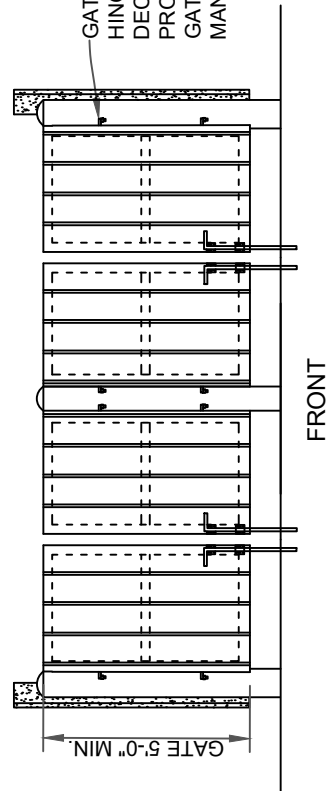

FRONT

NOT TO SCALE



CITY OF HICKORY

DOUBLE DUMPSTER PAD

DATE:
5/18/2022

SHEET 1 OF 3

STD. NO.
803

THE WALL SHALL BE CONSTRUCTED IN A DURABLE FASHION OF WOOD, METAL, BRICK AND OTHER MASONRY MATERIALS OR A COMBINATION THEREOF AS APPROVED BY THE PLANNING DIRECTOR. IF THE ENCLOSURE IS VISIBLE FROM A PUBLIC STREET, THE WALL AND GATE SHALL BE ARCHITECTURALLY COMPATIBLE WITH OTHER BUILDINGS AND STRUCTURES ON THE SITE.

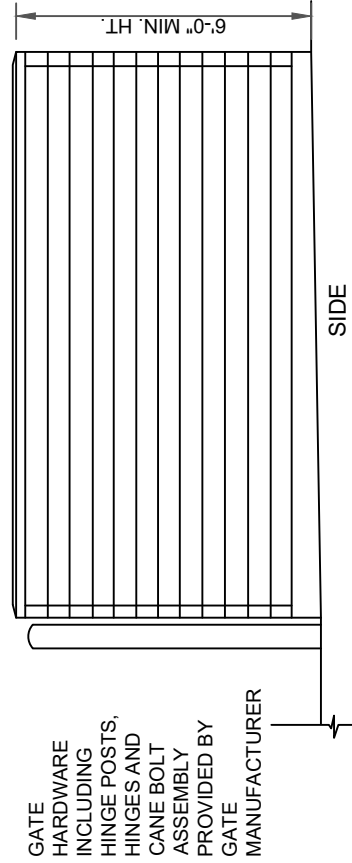

SIDE

CONCRETE PAD NOTES
 1. MINIMUM 6" CONCRETE WITH 6X6 W2.0XW2.0 WWF ON 6" ABC BASE

GATE HARDWARE INCLUDING HINGE POSTS, HINGES AND CANE BOLT ASSEMBLY PROVIDED BY GATE MANUFACTURER

6" DIA. STEEL HINGE POSTS PROVIDED BY GATE MANUFACTURER, FILL WITH CONCRETE WITH DOMED TOP

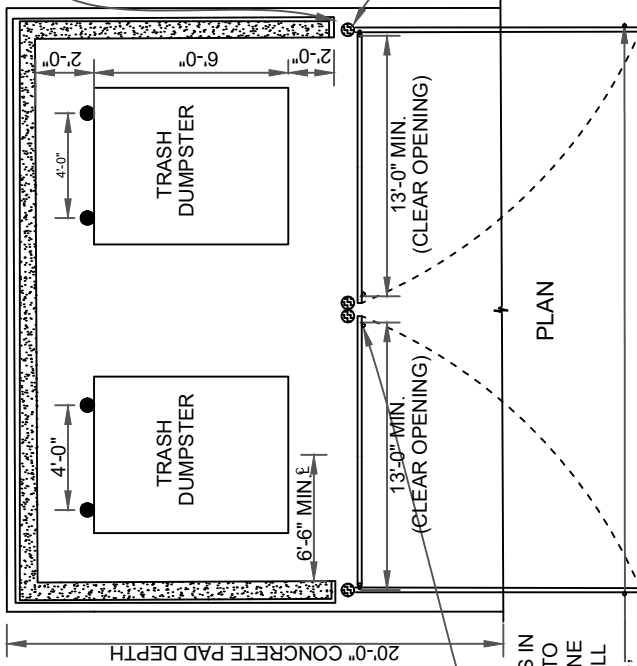

PLAN

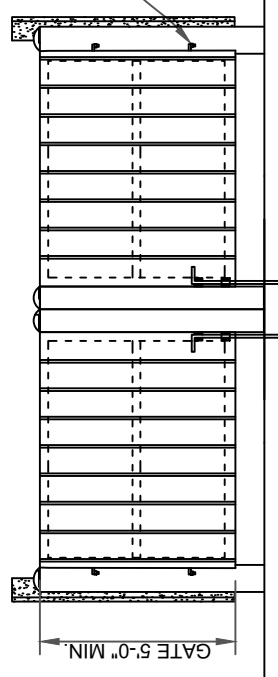

FRONT

GATE FRAME, HINGES AND DECK FACING PROVIDED BY GATE MANUFACTURER

DRILL HOLES IN CONCRETE TO RECEIVE CANE BOLT, INSTALL PVC SLEEVE, TYPICAL AT EACH DOOR

NOT TO SCALE

CITY OF HICKORY

DOUBLE DUMPSTER PAD WITH CENTER COLUMNS

SHEET 2 OF 3

DATE: 5/18/2022

STD. NO. 803

THE WALL SHALL BE CONSTRUCTED IN A DURABLE FASHION OF WOOD, METAL, BRICK AND OTHER MASONRY MATERIALS OR A COMBINATION THEREOF AS APPROVED BY THE PLANNING DIRECTOR. IF THE ENCLOSURE IS VISIBLE FROM A PUBLIC STREET, THE WALL AND GATE SHALL BE ARCHITECTURALLY COMPATIBLE WITH OTHER BUILDINGS AND STRUCTURES ON THE SITE.

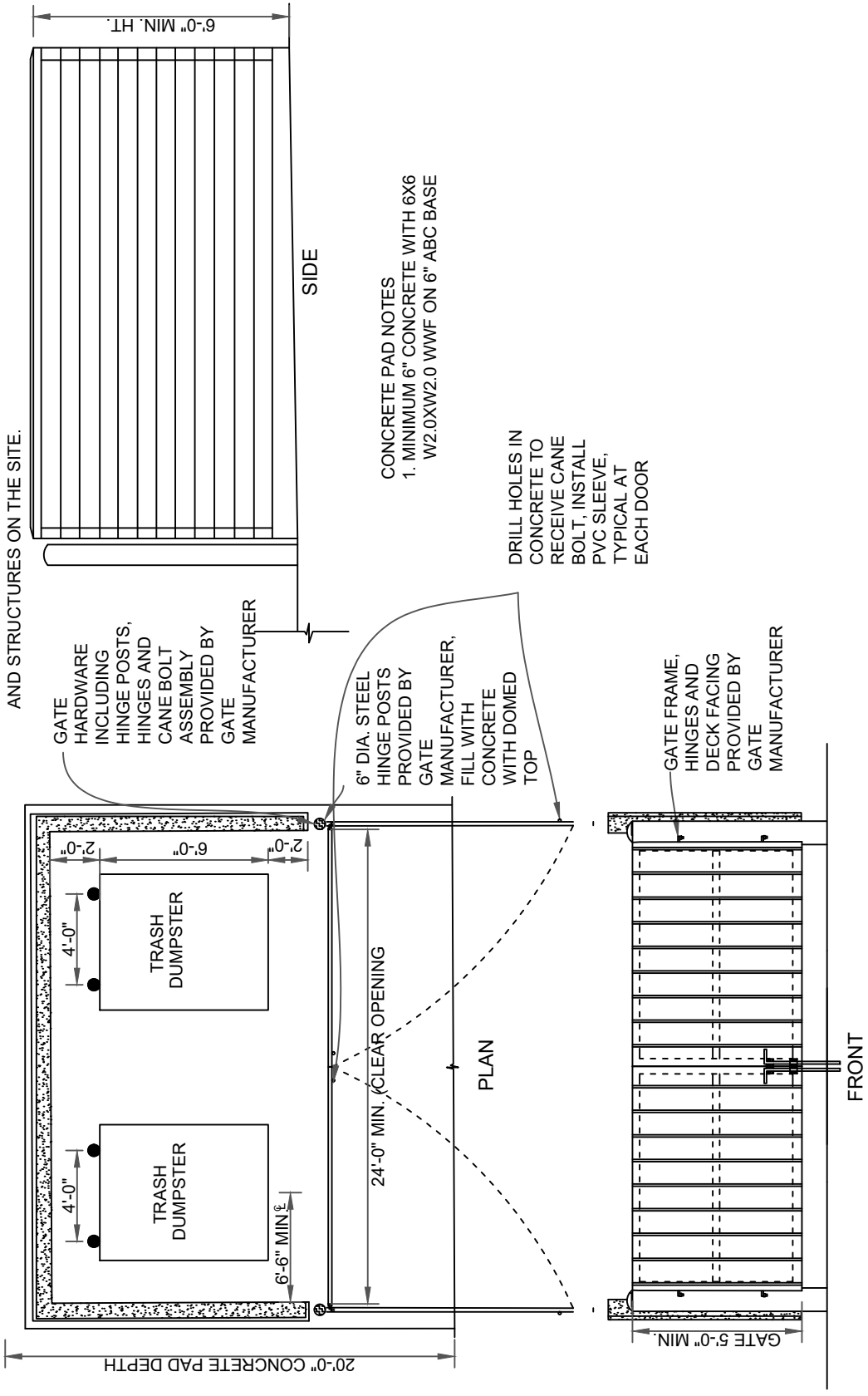

NOT TO SCALE



CITY OF HICKORY

DOUBLE DUMPSTER PAD WITHOUT CENTER COLUMNS

DATE: 5/18/2022	SHEET 3 OF 3
	STD. NO. 803

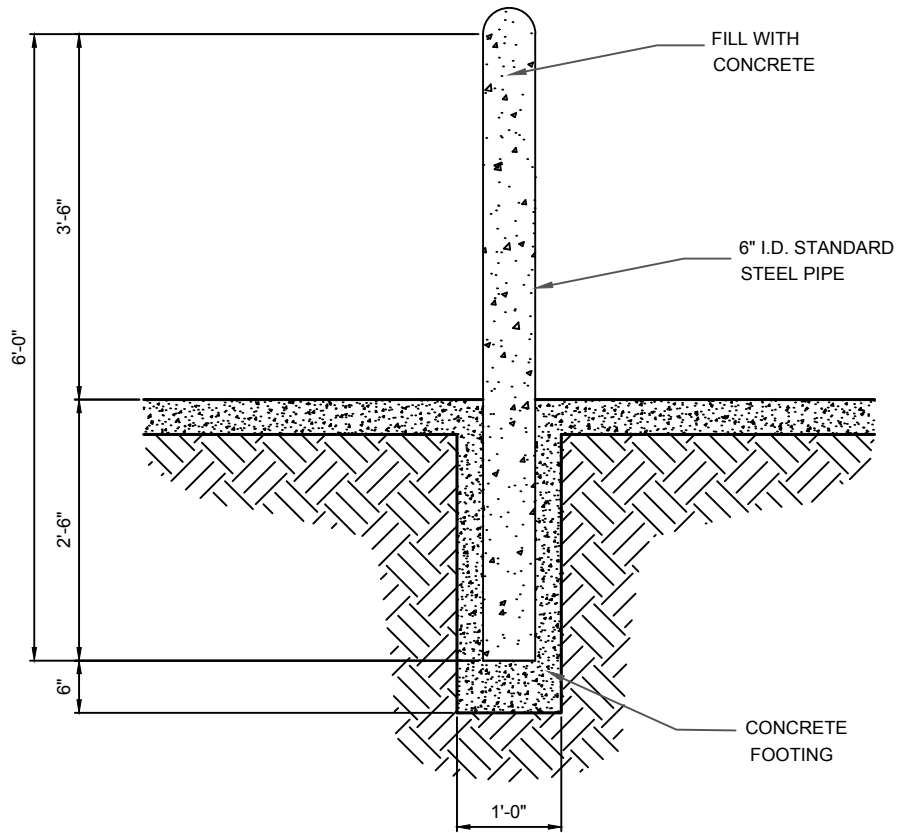

NOT TO SCALE



CITY OF HICKORY

BOLLARD DETAIL
FOR DUMPSTER

SHEET 1 OF 1

DATE:
1-12-11

STD. NO.
806